

 **Netti**[®] *EL-kit:*

***tilt-, recline- and
leg support control***

User Manual - for end user



*inspire
joy of life*

CONTENTS

1.	INTRODUCTION	3
2.	THE NETTI EL-KIT	4
	2.1 SPECIFICATION OF THE ELECTRICAL COMPONENTS	5
	2.2 ELECTROMAGNETIC INTERFERENCE AND WARNINGS	6
3.	DAILY USE OF THE NETTI EL-KIT	8
	3.1 REMOTE CONTROL	8
	3.2 KEY-LOCK	8
	3.3 CHARGER	9
	3.4 CHARGING	9
	3.5 FIRST USE	9
	3.6 WAKE UP PROCEDURE:	9
4.	GUIDELINES FOR USE	10
	4.1 TRANSPORT IN AIR-PLANE	11
	4.2 TRANSPORT IN CAR	
	4.3 MAINTENANCE AND CLEANING	12
	4.4 CLEANING AND WASHING	12
	4.5 LONG TERM STORING	12
5.	EL KIT MOUNTED	13
	5.1 NETTI III	13
	5.2 NETTI V	14
	5.3 TROUBLESHOOTING EL FUNCTIONS	15

1. INTRODUCTION

Netti El-kit is a kit for Netti multi-functional manual wheelchairs for wheeled transport for partially or fully immobile persons with physical and/or mental disabilities.

The Netti manual wheelchairs can be equipped with Netti electrical -tilt, -recline and -leg supports which ease the use of these functions.

The Netti electrical kit and components fit to the following wheelchairs: Netti III, Netti III HD, Netti V, Netti V All-round, Netti V El. Netti III EL and Netti III HD EL max user weight is 160 kg, but for Netti V, Netti All-round and Netti V EL it is 135 kg. They may be equipped with one or several of the electrical functions. The electrical features are operated with a hand control.

In this manual the different electrical features are presented with their mounting description.

 Electrical components are mounted by Alu Rehab or certified personnel.

In this manual important points are marked with the following symbols:

 **Symbol of forbidden actions.**
No warranty can be claimed whenever these actions are implemented.

 **Symbol of warning.**
Whenever this symbol is used, caution has to be taken.

 **Symbol for important information.**

 **Symbol for useful tips.**

 **Symbol for tools.**

 Please study this manual and pay careful attention to the user manual for the wheelchair where the Netti electrical kit have been mounted.

 User and attendant need instruction and training in the use of Netti wheelchair with electrical tilt-recline and leg supports.

 **ADJUST THE WHEELCHAIR TO THE USER:**

Adjust seat depth and eventually the wheelchair balance, foot board height, armrest height, head support height and depth, chair back cushion height.

 **ANTI-TIP** Correctly fitted, the anti-tip will secure the chair from tipping backwards. We strongly recommend the use of the anti-tips

 The El-kit is crash tested according to ISO 7176-19 and approved on the Netti wheelchairs where the kit can be mounted.



For more information about adapting the wheelchair to the user please see www.My-Netti.com knowledge and tools.

 Illustrations may differ from the delivered product.

 For visually impaired people, manuals and catalogues can be downloaded at www.My-Netti.com

2. THE NETTI EL-KIT ELECTRICAL COMPONENTS

Pos. 1 – 1 Control-box complete

Pos. 2 – 1 Charger

Pos. 3 – 2 Leg support-actuator-contacts with bracket

Pos. 4 – 1 Remote control

Pos. 5 – 1 Charging socket

Pos. 6 – 1 Back Recline Actuator - to be ordered separately - dependent on wheelchair model

Pos. 7 – 1 Tilt Actuator - to be ordered separately - dependent on wheelchair model

Pos. 8 – 1 Tilt actuator bracket - dependent on wheelchair model

Pos. 9 – 2 brackets for fixing pos 3 - leg-support-actuator-contacts

Pos. 10 Strips for holding wiring

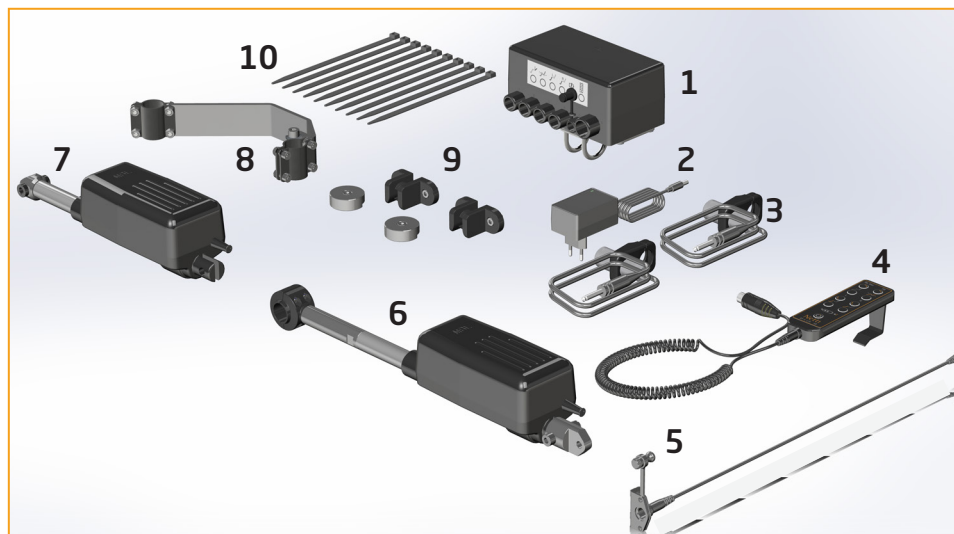

The products are CE-marked and follows EMC standard EMC 60601-1-2.

Weight of components:

Control box with batteries	750 gram
Tilt actuator:	1470 gram
Recline actuator:	1580 gram
Leg support actuator:	920 gram each
Hand control:	190 gram
Cable for charger:	20 gram
Total weight all inclusive:	5850 gram

The charger is free standing and not calculated as part of the weight of the wheelchair

2.1 SPECIFICATION OF THE ELECTRICAL COMPONENTS

The Control box with 24V 3.0 AH Li-ion battery.

The tilt and the recline actuators, the remote control and the actuator socket brackets for the leg supports are plugged into the control box.

The box is labelled accordingly.



Control box



Recline actuator

Actuator for Recline function and tilt function R 3000

Max push force	2000N – 3000N
Max pull force	2000N – 3000N
Max speed (full load)	2,3 – 9,6 mm/s
Max speed (no load)	5,0 – 16,0 mm/s
IP-class	IPX4
Current consumption (full load)	1,6A – 6,0A
Feedback & switches	Motor 24VDC standard



Tilt actuator

Actuator for leg supports RE1001

IP 41, 600N, 100MM, 24V, with special cable, with steel end bracket.

The actuator socket bracket for the leg supports are fixed on each side of the front cross tube at the seating frame.



Leg support

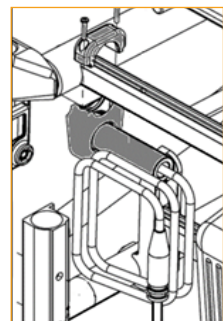

Socket for the leg support

2.2 ELECTROMAGNETIC INTERFERENCE AND WARNINGS



Wheelchairs with electrical functions / features may be susceptible to electromagnetic interference (EMI), which is interfering electromagnetic energy (EM) emitted from sources such as radio stations, TV stations, amateur radio (HAM) transmitters, two-way radios, and cellular phones. The interference (from radio wave sources) can cause the electrical functions to move by themselves. It can also permanently damage the electrical control system. The intensity of the interfering EM energy can be measured in volts per meter (V/m). Each electrical function can resist EMI up to a certain intensity. This is called its "immunity level." The higher the immunity level, the greater the protection will be. There are a number of sources of relatively intense electromagnetic fields in the everyday environment. Some of these sources are obvious and easy to avoid. Others are not apparent and exposure is unavoidable. However, we believe that by following the warnings listed below, your risk to EMI will be minimized.

Netti EL electrical functions degree of protection: IPX4.

Netti EL electrical functions are EMC approved.







 **It is very important that you read this information regarding the possible effects of electromagnetic Interference on your wheelchair with electrical features.**

THE SOURCES OF RADIATED EMI CAN BE BROADLY CLASSIFIED INTO THREE TYPES:

- A** Hand-held portable transceivers (transmitters-receivers) with the antenna mounted directly on the transmitting unit.
Examples include: citizens band (CB) radios, "walkie talkie," security, fire, and police transceivers, cellular telephones, and other personal communication devices.
-  **Some cellular telephones and similar devices transmit signals while they are ON, even when not being used.**
- B** Medium-range mobile transceivers, such as those used in police cars, fire trucks, ambulances, and taxis. These usually have the antenna mounted on the outside of the vehicle.
- C** Long-range transmitters and transceivers such as commercial broadcast transmitters (radio and TV broadcast antenna towers) and amateur (HAM) radios.
-  **Other types of hand-held devices, such as cordless phones, laptop computers, AM/FM radios, TV sets, CD players, and media players, and small appliances, such as electric shavers and hair dryers, so far as we know, are not likely to cause EMI problems to your wheelchair electrical features.**

The above listed devices and transceivers and Electromagnetic interference (EMI) from sources such as radio and TV stations, amateur radio (HAM) transmitters, two-way radios, and cellular phones can affect electrical functions and movement of the wheelchair. Therefore, the warnings listed below are recommended to prevent possible interference with the control system of the Netti III EL electrical features.

Following the warnings listed below should reduce the chance of unintended wheelchair movement, which could result in serious injury.

-  **Do not operate hand-held transceivers (transmitters-receivers), such as citizens band (CB) radios, or turn ON personal communication devices, such as cellular phones, while the power chair is turned ON.**
-  **Be aware of nearby transmitters, such as radio or TV stations, and try to avoid coming close to them.**
-  **If unintended movement occurs, turn the power chair OFF as soon as it is safe.**
-  **Be aware that adding accessories or components, or modifying the electrical functions on the wheelchair, may make it more susceptible to EMI.**
-  **Report all incidents of unintended movement to the distributor of the product. Note whether there is a source of EMI nearby.**
-  **The wheelchair might disturb the operation of devices in its environment that emit electromagnetic fields (e. g. alarm systems of shops, automatic doors etc.)**

3. DAILY USE OF THE NETTI EL-KIT

3.1 REMOTE CONTROL

The remote control unit is connected to the Control-box fixed to the wheelchair frame.

i A holder for hand control can be mounted as accessory.

On the remote control the icons are describing the different functions:



Hand control functions:

1. Recline forward
2. Recline back
3. Tilt forward
4. Tilt back
5. Left leg support up
6. Left leg support down
7. Right leg support up
8. Right leg support down

3.2 KEY-LOCK

A key lock function to lock one or several channels / functions is available.

- To lock a channel: press both buttons for that channel at the same time – for 3 seconds, until the alert indicator LED is lit. The channel is locked.

i If turning of the system with the on / off button and then start again, the red LED will light up for a short while to indicate that a key lock is active.

- To unlock: press both channel buttons at the same time for 3 seconds until the alert indicator LED is switched off.





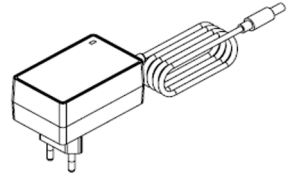

3.3 CHARGER

Mascot 2240 Pb 24D 0,5A IP67 insulation class 2
See separate user manual for the Mascot charger.



3.4 CHARGING

To charge the electrical kit you need to connect the charger to the charger socket on the right side of the wheelchair frame.



-  On the hand held remote controller the battery info LEDs indicates the level of battery power left.
-  The batteries should be recharged when the LED on the hand control is showing low battery.
Charge every day after use.
-  When the green light on the charger is glowing, the batteries are fully charged
-  Replace the rubber plug in the charger socket when the charging is finished.
-  Maximum charging time: 24 hours.
-  The chair cannot be used during charging.



3.5 FIRST USE

Connect battery:

Plug in the standard Mascot 24V charger delivered with the control box into the charger socket on the wheelchair. Plug in the charger into a wall socket. Wait 5 sec and unplug the charger. The battery is now connected.

-  Charge the batteries before first use.
-  **Automatic battery disconnect:**
To prevent deep discharge and protect batteries, the battery automatic goes into DEEP SLEEP if there is no operation within 30 minutes after power on.

3.6 WAKE UP PROCEDURE:

-  Push the power button on the hand control, the system will automatic wake up.

Charge the battery if required.

4. GUIDELINES FOR USE

The Netti with EL functions is often the choice for:

- Users with demand on frequent repositioning.
- Users who – with the electrical functions – can change the seating position themselves.

 Pay careful attention to the user manual for the wheelchair where the Netti electrical kit have been mounted.

 Always drive carefully.
Make sure your seating position is tilted and reclined in a way that you do have the overview when driving.

 Be cautious that you do not drive down too high steps.
You may lose steering control if the leg supports hit the ground and the leg supports may also brake.

 Always turn the chair OFF when transferring on or off or while the chair is stationary for long periods.

 Avoid carrying bags on the push handles, it may make the chair unstable.

 Always charge your batteries on a daily basis to make sure the electrical functions are working when you need them.
Disconnect the charger when the battery is full and the green light on the charger is blinking.

 Use only the charger delivered with the wheelchair and follow the user manual for this charger.

 Always charge in well tempered, dry, indoor surroundings.
Keep children, animals and other unskilled persons away from the charger.



Max backwards tilt and recline. Leg supports lifting

4.1 TRANSPORT IN AIR-PLANE

Netti wheelchair with Netti El components may be transported in air-plane. For complete passenger instructions contact your airline. Advanced arrangements and extra check-in time may be necessary.

Netti wheelchairs with Netti El components are equipped with 4 actuators and control system and the control box with 24V 3.0 Ah (72 Watt-hours) Li-ion battery. To ensure the safety of Li-ion battery during transport the battery has obtained UN38.3 and MSDS reports. If you have such transportation needs, Netti will support you and provide you with these safety inspection reports.

If Netti wheelchair with El components is not configured with complete electrical kit (tilt + recline + el leg supports) the not electrical function is activated with gas spring(s). Contrary to general dangerous goods instruction UN3164, the IATA-DGR (special regulation A114) rules that the goods that contain gas and are determined to function as shock absorbers (including energy-absorbing devices or pneumatic springs) are NOT subject to the transport instructions i. e. they are indemnified from the following requirements:

- a) Each article has a gas volume which does not exceed 1,6 l and a charge pressure not exceeding 250 bar, where the product of the capacity expressed in litres and charge pressure expressed in bars does not exceed 80.
- b) Each article has a minimum burst pressure of 4 times the charge pressure at +20 degree Celsius for products not exceeding 0,5 l gas space capacity.
- c) Each article is made of material that will not fragment.
- d) Each article was manufactured in accordance to quality standard which is approved by the responsible national authority.
- e) It is proven and shown that the article relieves its pressure by means of a fire degradable seal or other pressure relief device such that the article will not fragment and the article does not rocket.

4.2 TRANSPORT IN CAR

Netti III, Netti III HD and Netti V are all crash tested and approved to be used as seat in car.

The Netti El kit is tested and approved - on a Netti wheelchair and is approved to be used as seat in a car.

A separate user manual

UM 0131 How to use as Netti wheelchair as a seat in a car

- with detailed information about how a wheelchair is to be handled, positioned and secured when the wheelchair is to be used as a seat in a car.



Follow the instructions in UM0131 manual carefully.
to be downloaded from My-Netti.com

4.3 MAINTENANCE AND CLEANING



You as a user of the wheelchair (and your attendants and family) are responsible for the everyday maintenance of the chair. Clean it regularly and do the maintenance to ensure safe and long time reliable functions and hygienic appearance.

Maintenance Frequency	Weekly	Monthly
Check defects / damages e. g. breakage / missing parts	X	
Washing of wheelchair		X
Washing of cushions		X
Check anti-tip function		X
Check brake adjustment		X
Check tyre wear		X
Oiling of bearings and sliding profiles with bicycle oil or Vaseline		X
Charge batteries – daily	XX	

4.4 CLEANING AND WASHING

1. Remove cushions before washing the chair.
2. Wipe all electrical components with a damp cloth and do not wet them.
3. Clean the frame using water and a rag.
4. We recommend using soft soap.
5. Rinse the wheelchair well using clean water to remove all the soap – without wetting the electrical components.
6. Use methylated spirit removing dirt left.
7. Clean cushions and covers according to instructions printed on cushions.

CLEANING electrical components

Actuators

The actuators are cleaned for dust and dirt according to need and should be optically checked for mechanical damage and breakage on a regular basis. The actuators should be wiped with a damp cloth.

Remote control

The remote control should be wiped with a damp cloth according to need.

Control box

The control box should be wiped with a damp cloth according to need, the sockets should only be wiped on the inside with a dry cloth.

Charger

The charger must be wiped with a dry cloth.

Disinfection: wipe the whole chair with a soft cloth wetted in hydrogenperoxid or isopropanol.



Never clean a wheelchair with electrical components in a washing machine or with jet stream.



Check / re-adjust screws and nuts at regular intervals.



Sand and sea water (salt used for gritting in the winter) can damage the bearings of the front castors and main wheels. Clean the wheelchair thoroughly after use.

* As a rule of thumb, use oil on movable parts and all bearings. Alu Rehab recommends use of ordinary bicycle oil.

4.5 LONG TERM STORING

If the wheelchair is to be stored for longer time (longer than 4 months) the battery must be recharged every 3rd month.

We recommend that the chair is cleaned before storing.

,Complete the above maintenance instructions before taking it into use again.



If in doubt – contact your dealer!

5. EL KIT MOUNTED

5.1 NETTI III

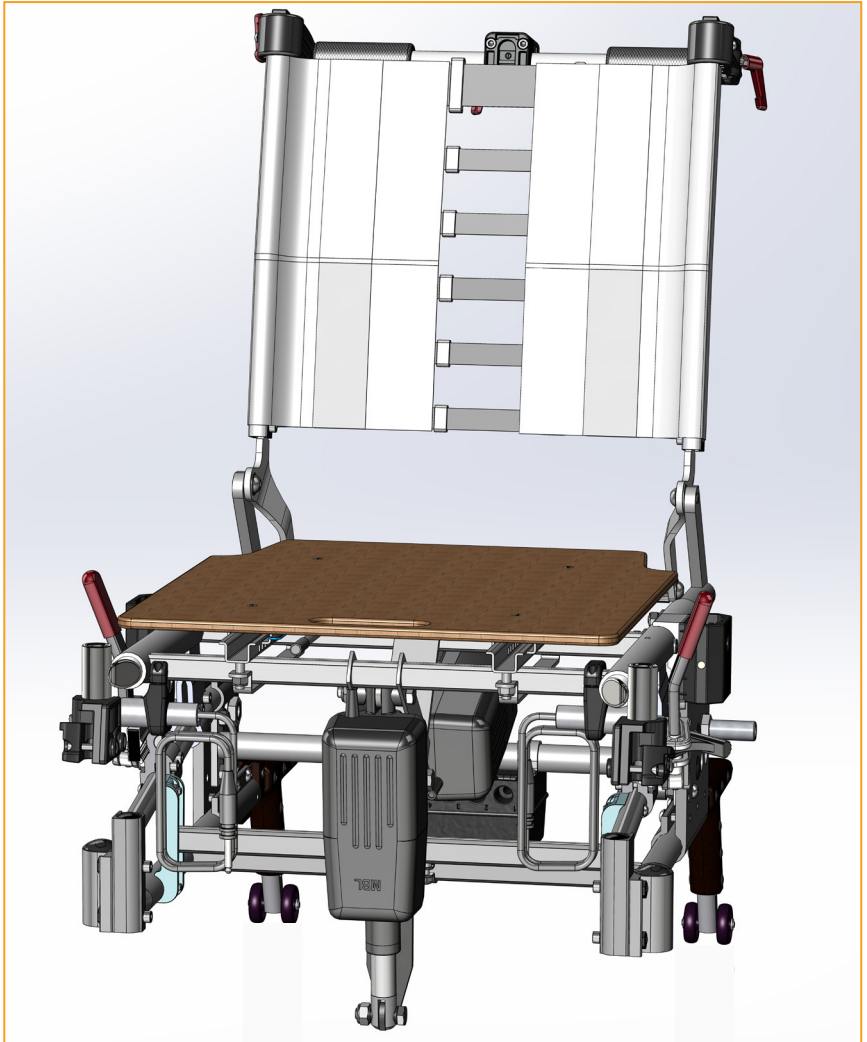

5.2 NETTI V

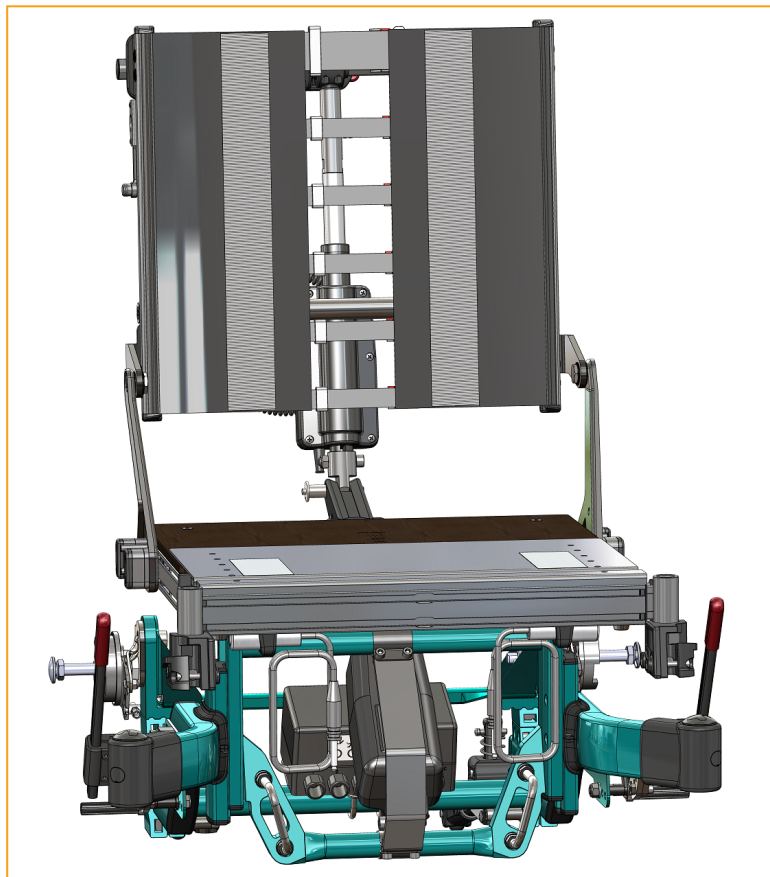

FRONT VIEW OF NETTI V WITH EL KIT MOUNTED

No leg supports attached.

5.7 TROUBLESHOOTING EL FUNCTIONS

General **The procedure below is to be followed for all the actuators.**

If an actuator is not responding when pressing the remote control panel:

BATTERY and CHARGER check:

- Check battery status on the remote control panel.
- Set the wheelchair to charge. It will increase the actuator performance if the control box is low on battery.
- Check that the charger is charging: Green light when connecting to current - this changes to red when the charging is taking place and back to green when the battery charging is complete.
If the charger show no light when connected to current, the charger is defect and need replacement.
- Check that the battery is being charged on the remote control - it show running LED lights.
- If the charger does not charge, connect it direct to the control box (1). If it now charges there is a remote control cable (5) breakage.
- If it does not charge with the charger connected to the control box, the battery is probably defect. Open the control box and check battery voltage. If the battery voltage is too low (less than 18V) replace the battery.
- If the battery voltage is OK, the control box is defect. (Fully charged battery voltage is 24,6V)

ACTUATORS NOT WORKING:

- Check that the Key lock function is not active. The red indicator LED next to battery LED indicator on the remote control, lights up when the key lock is active. **To unlock:** press both channel buttons at the same time for 3 seconds until the alert indicator LED is switched off.
- Check that all contacts to the actuators are securely in position.
- If an actuator has had an overload it will stop. Turn the power off and on on the remote control to activate the actuator again
- If the actuator still does not work, connect it to another outlet on the control box. If it still does not work the actuator needs to be replaced.
- If extension cable (3)Y-adapter is used the actuator must be directly connected to the control box to eliminate possible breakage in the extension cable /Y-adapter, which need replacement if defect.
- If a leg support actuator is not working, switch side of the leg supports. If it still does not work it needs to be replaced. If the other leg support is not working now, check the extension cable/Y-adapter by connecting the leg support direct to the control box. If it works the Y-adapter needs replacement.
- If it does not work, try another remote control. If a new remote control does not work, replace the control box.

Troubleshooting for Netti electrical equipment:

Symptom	Possible cause	Action to be taken
No response on remote control	Poor connection Low battery level Defective remote control	Check cables and connections Check the battery Try another remote / replace if necessary
No charging	Defective charger / no lights Poor connection /defect cable Battery is not receiving current	Replace charger Check connections & cables, connect the charger directly to the control box. Replace battery (battery voltage 18-24,6 V)
Battery is discharged to quickly	Old battery	Replace battery
Actuators not moving	Low battery level Bad connections Defective outlet Defective actuator Defective remote control	Charge the battery Checks cables and connections Try another outlet, replace actuator Replace actuator Replace remote control
Actuator moving only one direction	Actuator overloaded	Turn power off and on, on the remote control
Actuator clicks/ move unevenly	Low battery level	Check battery indicator, Charge battery

Manufacturer of Netti:

📍 Alu Rehab AS
Bedriftsvegen 23
N-4353 Klepp Stasjon
Norway

✉ post.klepp@meyragroup.com
T: +47 51 78 62 20
my-netti.com

EU Distributor

Alu Rehab ApS
Kløftehøj 8
DK-8680 Ry
Denmark

info.ry@meyragroup.com
T: +45 87 88 73 00
my-netti.com