



 **Netti**[®] *AdaptPro*

Patent N02019050262

User Manual



CE This product conforms to regulation MDR
(EU)2017/745 for medical products.

UM0136 UK 2025-03

*inspire
joy of life*

CONTENTS

1. INTRODUCTION	6
1.1 AREAS OF USE / INDICATIONS FOR NETTI <i>AdaptPro</i>	7
1.2 CONTRA INDICATIONS	7
1.3 QUALITY AND DURABILITY	8
1.4 THE ENVIRONMENT AND WASTE DISPOSAL	8
1.5 INFORMATION FOR RE-USE	9
1.6 ABOUT THIS MANUAL	10
1.7 VITAL MEASURES	11
2. QUICK REFERENCE	14
3. DESCRIPTION	16
3.1 INFORMATION ABOUT NETTI <i>AdaptPro</i> SYSTEM	18
3.2 HOW THE NETTI <i>AdaptPro</i> FRAME WORKS	20
4. FEATURES OF NETTI <i>AdaptPro</i>	23
4.1 ACCESSORIES	24
5. ASSEMBLING AND ADJUSTMENT	28
5.1 UNPACKING	28
5.2 INITIAL ADJUSTMENTS TO THE USER – OVERVIEW	29
5.3 WHEELS ASSEMBLING	30
5.3.1 DRIVE WHEELS	30
5.3.2 FRONT FORK	31
5.3.3 FRONT CASTORS	31
5.3.4 FRONT CASTOR BEARING HOUSE DEPTH ADJUSTMENT	32
5.3.5 CORRECT FRAME ANGLE	33
5.3.6 MAIN WHEEL QUICK RELEASE	34
5.3.7 DRUM BRAKE ADJUSTMENT	35
5.3.8 OPERATING THE BRAKES	36
5.4 SEAT ASSEMBLING – WHEELCHAIR SEAT HEIGHT	37
5.4.1 SEAT HEIGHT – WHEEL POSITIONS	37
5.4.2 SEAT HEIGHT AT THE REAR	37
5.4.3 SEAT HEIGHT AT THE FRONT	39
5.4.4 NETTI SEAT PLATE	39
5.4.5 SEAT DEPTH – ADJUSTING AT THE REAR	41
5.4.6 SEAT DEPTH – ADJUSTING THE SEAT PLATE LENGTH AT THE SEAT PLATE MIDDLE	42
5.4.7 SEAT DEPTH – ADJUSTING AT THE SEAT PLATE POSITION IN THE FRONT	43
5.4.8 FIXED SEAT PLATE	45

5.5	CHAIR BACK ASSEMBLING AND POSITIONING	46
5.5.1	ADJUSTING THE VELCRO BACK	46
5.5.2	PLACING BACK SUPPORT CUSHION	48
5.5.3	BACK EXTENDER	48
5.6.	ASSESSMENT AND CHOICE OF BACK SUPPORT CYLINDER	49
5.6.1	CHANGE OF RECLINE GAS CYLINDER	50
5.6.2	CHANGE OF TILT GAS CYLINDER	52
5.7	NETTI HEAD SUPPORT ASSEMBLING AND POSITIONING	53
5.7.1	NETTI HEAD SUPPORTS	53
5.7.2	NETTI DYNAMIC HEAD SUPPORT ADJUSTMENTS	54
5.7.3	NETTI PUSH BOW TIGHTENING	54
5.8	ARM SUPPORTS ADJUSTING	55
5.8.1	ARM SUPPORTS HEIGHT – AT THE FRONT	55
5.8.2	ARM SUPPORTS HEIGHT – AT THE REAR	55
5.8.3	ARM SUPPORTS HANDLING	56
5.9	BELTS AND HARNESSSES	57
5.10	LEG SUPPORTS	61
5.10.1	LEG SUPPORT HEIGHT AND LENGTH ADJUSTMENTS	61
5.10.2	GRANDIS LEG SUPPORTS	62
5.10.3	GRANDIS FIXED LEG SUPPORTS	66
5.10.4	ANGLE ADJUSTABLE LEG SUPPORTS	68
5.10.5	NETTI DUAL LEG SUPPORTS	73
5.10.6	LOCKING THE NETTI DYNAMIC DUAL LEG SUPPORT	82
5.10.7	ADJUSTMENTS FOR DIFFERENT LEG LENGTHS	83
5.10.8	LEG SUPPORT MOUNTING AND REMOVAL	86
5.10.9	FOOT PLATE LOCK	87
5.11	SIDE SUPPORTS	88
5.12	ABDUCTION BLOCK	89
5.13	THIGH SUPPORT	90
5.14	TABLE	90

6. EVERYDAY USE OF NETTI *AdaptPro* **91**

6.1	KEY WORDS REGARDING TILT AND RECLINE OF COMFORT WHEELCHAIRS	92
6.2	DECREASE THE POSSIBILITY OF SLIDING, SHEAR AND PRESSURE SORES	92
6.3	OPERATING RECLINE: RECLINING THE CHAIR BACK	93
6.4	OPERATING TILT: TILTING THE SEATING UNIT	93
6.5	PRACTICE THE USE OF THE NETTI <i>AdaptPro</i> TILT AND RECLINE SYSTEM TOGETHER WITH THE USER	94
6.6	TRANSFER TO AND FROM THE WHEELCHAIR	95
6.7	USING A PATIENT HOIST	95
6.8	DAILY ATTENDANT HANDLING	96
6.8.1	PUSH BOW	96
6.8.2	ANTI-TIPS	97
6.8.3	BRAKES	98
6.8.4	ARM SUPPORTS	99

6.8.5	HEAD SUPPORT – MOUNTING	100
6.8.6	LEG SUPPORTS – MOUNTING	101
6.8.7	LEG SUPPORT FOOT BOARD	102
6.8.8	LOCKING DYNAMIC LEG SUPPORTS	103
6.9	BELTS AND HARNESSSES	104
7.	TRANSPORT	106
7.1	TRANSPORT IN CAR	106
7.2	FOLDING FOR TRANSPORT	109
7.3	TRANSPORT IN AIR-PLANE	110
7.4	TRAVELLING ON PUBLIC TRANSPORT	110
8.	MANOEUVRING	111
8.1	GENERAL TECHNIQUES	111
8.2	DRIVING TECHNIQUES – STEP UP –	114
8.3	DRIVING TECHNIQUES – STEP DOWN –	115
8.4	DRIVING TECHNIQUES – SLOPE –	115
8.5	DRIVING TECHNIQUES – UP AND DOWN STAIRS –	116
8.6	TRANSFER	116
8.7	POINT OF BALANCE	118
8.8	LIFTING THE WHEELCHAIR	118
8.9	PUSH RIM	119
9.	MAINTENANCE	120
9.1	MAINTENANCE INSTRUCTIONS	120
9.2	CLEANING AND WASHING	120
9.3	LONG TERM STORING	121
10.	TROUBLESHOOTING	122
11.	TESTS & WARRANTY	123
11.1	TESTS	123
11.2	WARRANTY	123
11.3	CLAIM	124
11.4	NETTI CUSTOMIZED / INDIVIDUAL ADAPTATIONS	124
11.5	COMBINATIONS WITH OTHER PRODUCTS	125
11.6	SERVICE AND REPAIR	126
12.	MEASUREMENTS & WEIGHT	127



1. INTRODUCTION



Netti *AdaptPro* is a tilt and recline wheelchair with seating system for adolescent and grown up users meant for mainly indoor and some outdoor use. It is tested to EN 12183. The tests were carried out by accredited German test institute.

In Alu Rehab we believe that wheelchairs should be chosen based on a thorough assessment focusing on the needs of the user and demands from environment. It is vital to be aware of the possibilities and limits the wheelchair offers. Netti *AdaptPro* is a wheelchair designed for users with great need of comfort and adjustments. It has an adjustable seat and back angle, thus facilitating for the user change of position, mobilisation or posture correction (stabilization).

Netti *AdaptPro* has been crash tested at TASS International test centre in Helmond Netherlands, according to ISO 7176-19.

-  **Max. user weight is 135 kg, also when used as a seat in a car.**
-  **When mounting accessories such as power kit etc., the weight of the accessories must be subtracted from the max. user weight.**
-  **Specifications varies between countries.**



1.1 AREAS OF USE / INDICATIONS FOR *NETTI AdaptPro*

Netti AdaptPro is a multifunctional, tilt and recline comfort wheelchair for wheeled transport for partially or fully immobile adolescent and grown up persons with physical and/or mental disabilities. *Netti AdaptPro* has a modular system that can be customized and adjusted according to the user's need. It provides a means by which a disabled person who requires the possibility to vary the sitting position from activity to rest will profit from using tilt and recline functions. It is designed for users with the need for comfort and relief. The combination between the seating system and the ergonomic solution in the frame construction offers many possibilities for adaptation and adjustments.

IMPORTANT BENEFITS of *Netti AdaptPro*

The disabilities may have multiple causes. *Netti AdaptPro* has an adjustable seat and back angle, thus facilitating for the user change of position, mobilization or posture correction (stabilization), wherever the following functional impediments with their multiple possible causes are present:

- limited or lacking mobility
- limited or lacking muscle power
- limited movement range
- lacking or limited trunk and body stability
- hemiplegia
- rheumatic-type disorders
- craniocerebral injuries
- amputations
- other neurological or geriatric disorders.



Before using *Netti AdaptPro*, a seating assessment should be carried out by a trained professional.



If our standard solutions does not cover you needs, please contact our customer service for *Netti* customized solutions.

1.2 CONTRA INDICATIONS

Netti AdaptPro should not be used if:

- The user has strong involuntary movements. It is recommended the use of *Netti Dynamic System* for these users.

1.3 QUALITY AND DURABILITY

The Netti AdaptPro Wheelchairs are tested at an accredited German test institute following the European standard EN 12183.

As manufacturer, Alu Rehab A.S evaluates the test to be equal to 5 – 6 years of normal use of the chair. The disability of the user, the toughness of use as well as the level of maintenance done, foremost decides the durability of the wheelchair. Thus, the durability will vary depending on these three factors. With adequate maintenance, the lifetime of the wheelchair can be expected to exceed the 5-year warranty period by many years.

1.4 THE ENVIRONMENT AND WASTE DISPOSAL

Alu Rehab and its suppliers wish to protect the environment.



This means:

- That we avoid using environmentally harmful substances and processes to the greatest extent possible.
- That Alu Rehab's products are ensured a long service life and a high degree of flexibility – to benefit the environment and economy.
- That all packaging can be recycled.
- That the wheelchair was designed to be separated into its component materials – to make recycling easier.



Contact your local recycling agent to get correct information how to handle in your area.



TEMPERATURE RANGE

Netti *AdaptPro* wheelchair is designed for temperature range of – 10 ° C to + 40 ° C.

1.5 INFORMATION FOR RE-USE

All products from Alu Rehab are designed to give years of little maintenance service. All products can be adapted for re-use by an authorised dealer. In order to guarantee performance and safety, Alu Rehab recommends the following tests prior to any re-use.

Please examine the following components for function, integrity etc. and replace parts if necessary:

- Wheels (tyre tread) and quick release
- Wheelchair frame
- Front castors and quick release
- Hubs
- Brake function
- Directional stability of wheels
- Bearings: test for wear and lubrication
- Cushions
- Leg supports
- Arm supports
- Recline / tilt function
- Push bar / handles
- Anti-tip

If electrical functions are mounted, please check:

- Batteries – may need to be replaced
- Control box
- Charging point and all connectors
- Joystick
- Electrical functions of all actuators.

For hygienic reasons: please replace the head support cover for a new user.

Please also note the contents of Section 10.2 Cleaning and care.



A refurbishment manual for Netti Wheelchairs can be downloaded at [My-Netti.com](https://www.my-netti.com)



A recycling manual for Netti Wheelchairs can be downloaded at [My-Netti.com](https://www.my-netti.com)

1.6 ABOUT THIS MANUAL

In order to avoid damages while using the Netti *AdaptPro* wheelchair, please read this manual carefully before starting to use the chair.



Symbol of forbidden actions.
No warranty can be claimed whenever these actions are implemented.



Symbol of warning.
Whenever this symbol is used, caution has to be taken.



Symbol for important information.



Symbol for useful tips.



Symbol for tools.



Symbol for:
Max safe slope for hand brake.



Symbol for: Max user weight.



Medical Device



Manufacturer – Name and address



Date of manufacturing



Serial number



Read user instruction



Please note that this manual is updated according to the year and date stated on each page.

User Manual on web – My-Netti.com

For enhanced readability (advantageous for users with visibility challenges) please find our user manual on our web page: www.My-Netti.com – manuals – user manual Netti *AdaptPro*.

Latest user manual updates, product safety notes, addresses and other product information like recalls etc. will be published on our web page.

1.7 VITAL MEASURES

Netti *AdaptPro* is a comfort wheelchair designed for mainly indoor use, it can be used outdoor on smooth and level ground.
Min. dimension in table refer to seat width 350 mm.
Max. dimension refers to seat width 500 mm.

 **Specifications varies between countries.**

TOTAL WEIGHT: 53 KG

(450 mm width chair)

SEAT WIDTH:

350, 380, 400, 430, 450, 500 mm

(8 mm less between arm support pads)



SEAT DEPTH:

From back Velcro to front of seat plate:

By sw 350 – 400 mm:

380, 405, 430, 455 mm

(355 mm – not available with

Grandis leg supports)



By sw 430 – 500 mm:

(405 mm*) **430, 455, 480, 505 mm**

(*Minimum seat depth with the chair-back in forward mounted position)

SEAT HEIGHT:

(From floor to top seat plate using 24" main wheels in third hole position)



415 mm*

* By changing position of main wheels, it is possible to achieve seat height of 445 mm. Other seating heights can be reached by changing wheel dimensions and wheel brackets.

BACKREST HEIGHT:

515 mm*

* Using the backrest extender gives up to 610 mm backrest height.



For Netti *AdaptPro* with seat width 500 mm and more, the overall width exceeds recommended 700 mm.

Specification	min.	max.
Overall length with leg-rest – horizontal seat, back and leg supports vertical. Max length: tilt 30 degree inclusive push bow	1280 mm	1600 mm
Overall width = seat with + 232 mm **	582 mm	732 mm
Folded length – ex leg supports	800 mm	800 mm
Folded width (removed wheels)	538 mm	688 mm
Folded height (removed wheels cushions, arm, head and leg support, back folded forward)	715 mm	715 mm
Total mass – all inclusive	55.5 kg	55.5 kg
Mass heaviest part: frame	35 kg	38 kg
Mass heaviest component: Grandis leg support	3 kg	4 kg
Static stability downhill	0°	13°
Static stability uphill	0°	13°
Static stability sideways	15°	15°
Safe slope, use anti-tipper	0°	7°
Seat plane angle	-3°	30°
Effective seat depth	355 mm	505 mm
Effective seat width	350 mm	500 mm
Seat surface height at front 24" main wheel (max. with change of wheel size)	415 mm	445 mm
Backrest angle	87°	133°
Backrest height ex cushion	515 mm	625 mm
Foot board to seat distance	280 mm	560 mm
Leg to seat surface angle	99°	180°
Arm support to seat distance	265 mm	375 mm
Front location of arm support structure	408 mm	450 mm
Push rim diameter	540 mm	540 mm
Horizontal axle location	-10 mm	95 mm
Parking brake Max slope	-	7°
Minimum turning radius, without leg supports	R 500 mm	R 560 mm

**Model with 24" main wheels.
Measured without cushions.**

2. QUICK REFERENCE

The content of this page is a summary of the whole manual. It gives you a brief introduction to the use and care of the Netti *AdaptPro* wheelchair.

 **The quick reference is not a replacement for the manual, only a reminder / check list.**

- Unpack the wheelchair (Chapter 5.1)
- Mount the main wheels (Chapter 5.3)
- Mount the front castors (Chapter 5.3)
- Rise the backrest and mount the recline gas strut to the backrest using the locking bolt (Chapter 5.5)
- Adjust the arm supports (Chapter 5.7)
- Mount the cushions (Chapter 5.4 and 5.5)
- Mount the leg supports (Chapter 5.9)
- Adjust the push bow (Chapter 6.6)
- Mount the head support (Chapter 5.6)
- Mount accessory (See chapter 5 for more information. Mounting descriptions will follow the accessory.)
- If electrical functions are mounted:
Connect the battery and start electrical functions.

 **ADJUST THE WHEELCHAIR TO THE USER:
Adjust seat depth and eventually the wheelchair balance, foot board height, armrest height, head support height and depth, chair back cushion height.**

For more information about adapting the wheelchair to the user please see www.My-Netti.com knowledge and tools

 **For troubleshooting, see chapter 11.
For adjustments see chapters 5.**

 **ANTI-TIP: The rearward position of the anti-tips are defined and placed in relation to the drive wheels. They will follow the drive wheels independently from which tilt angle is used. This will secure the chair from tipping backwards at any time.**

 **If in doubt – contact your dealer!**

 **Drive carefully!**







 **Be aware that friction against push rims can create a warm surface.**

 **Surface temperature of metal parts in frame structure might increase when exposed to direct sunlight.**

 **Salt water can increase risk of corrosion. Further precautions related to environmental conditions not needed.**

 **The anti-tips are always used for the safety of the user.**

 **When the chair is tilted rearwards, the anti-tips are automatically moved backwards, the brakes must always be used when leaving the user in the backwards tilted position.**

-  Be sure to lock all handles properly.
-  Watch out for pinching danger when folding and unfolding, tilting, reclining and all other adjustment movements.
-  If electrical functions are mounted:
Charge the battery daily.
-  If the chair has pneumatic tires:
Make sure to check tyre pressure every week and inflate to keep 24" at 45 PSI, and 7" at 36 PSI.
-  Never stand on the foot plates due to risk of tipping forwards.
-  Never lift the wheelchair by the leg supports, arm supports or head support.

 **Product configuration may vary between different countries.**

 **For visually impaired people, manuals and catalogues can be downloaded at www.My-Netti.com**

3. DESCRIPTION

1. Head support
2. Backrest cushion – model Stabile
3. Arm support with pad
4. Seat cushion
5. Knee pad
6. User brake right
7. Bearing house / front fork fastening
8. Quick release for front fork
9. Front fork
10. Front castors
11. Foot plate lock
12. Foot plate
13. Calf support
14. Angle adjustment screw
15. Height adjustment screw
16. Leg support bracket
17. Anti-tip
18. User Brake – parking brake
19. Quick release axle
20. Push rim
21. Main wheel
22. Name plate wheelchair
on lower back cross bar
23. Release handle for
arm support
24. Attendant drive brake
25. Release handle for push bow
26. Push bow
27. Head support height handle



Be aware that specifications may vary between countries.



If any of these parts are missing, please contact your dealer.



For complete information, please contact your dealer.



Be aware that illustrations and pictures may differ from your received product.

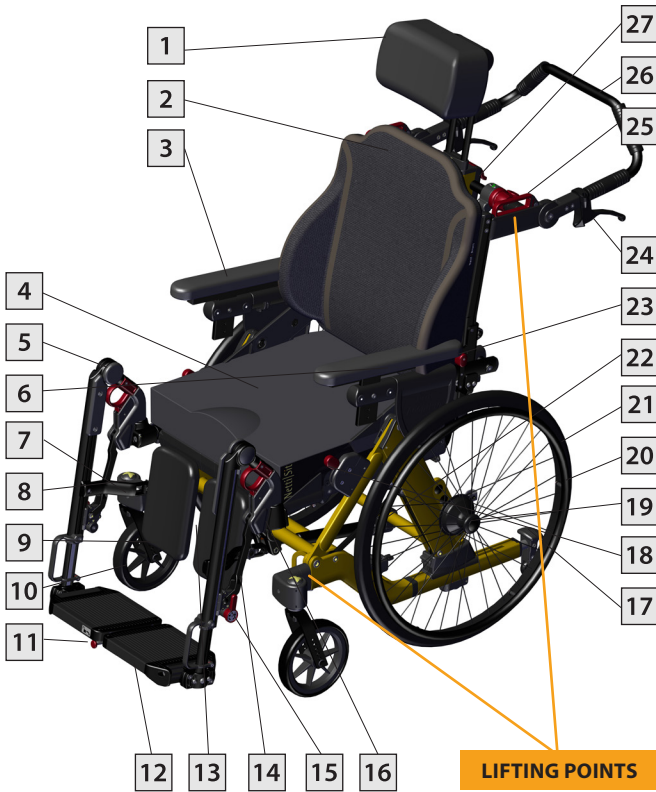

3.1 INFORMATION ABOUT NETTI *AdaptPro* SYSTEM

Netti *AdaptPro* is an advanced mobility aid incorporating the Netti patented solution:

- Advanced *AdaptPro* frame with large tilt span.

Tilt range:

The patented Netti *AdaptPro* wheelchair frame allows for extensive tilt range from 3° forwards to 30° backwards. The innovative frame structure adapts to the tilt angle by moving the main wheels backwards ensuring that the gravity point always stays within the footprint of the wheels. This ensures the stability of the wheelchair in any tilted position. The anti-tips follow the main wheels and are therefore always keeping the anti-tip security.

Manoeuvrability:

Netti *AdaptPro* has a very short wheel base of 375 mm when 3° forward tilt is used, ensuring easy manoeuvring in narrow spaces. The wheel base increases up to 465 mm when the chair is tilted 30° backwards.

Netti *AdaptPro* is developed for users in need for varying seating positions.



30° max. tilt



30° max. tilt – 133° max. recline



3.2 HOW THE NETTI *AdaptPro* FRAME WORKS

Netti *AdaptPro* frame is a patented frame construction with innovative tilt and recline functions.

It has been developed as an answer to the users seemingly adverse requests for a very large tilt range, without expenses of reduced stability and manoeuvrability. It is also covering the need for low seating height for users that use their feet to move the wheelchair by tripping.

The solution is a wheelchair frame that have a short wheel footprint at upright sitting position – allowing for very good manoeuvrability in narrow space – while it increases the footprint as soon as the seating tilt function is used. This allows the centre of gravity of the chair to stay well within the wheels footprint at any tilted position – which lead to very good stability at any time.

As an additional safety feature, the anti-tips follow the backwards movement when the tilt function is activated.

TILT RANGE:

The patented Netti *AdaptPro* wheelchair frame allows for extensive tilt range. On the Netti *AdaptPro* it is set from 3° forwards to 30° backwards.

THE TILT FUNCTION:

is operated from the red tilt handle at the left side on push bow.

To operate:

- Turn the tilt handle towards you and put pressure to the push bar to tilt up or down.

The seating unit remains tilted in the position where you let the tilt handle loose.

The tilt handle operates 2 tilt gas cylinders sitting under the seat frame. via bowden control cables. The 2 gas cylinders are operated simultaneously.

The tilt cable from the tilt handle goes to a split box sitting on the frame. From the split box 2 wires – one to each cylinder are operated.

Tilt cylinder adjustments see chapter 5.6.

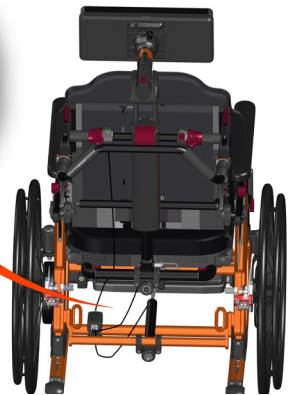

THE RECLINE FUNCTION:

is operated from the blue recline handle at the right side on push bow.

The chair back can be reclined and locked in any angle.

To operate:

Pull the blue recline handle towards you and put pressure to the push bar to recline the back up or down.

The back remains reclined in the position where you let the recline handle loose.

Recline / dynamic gas cylinder adjustments see chapter 5.6.



4. FEATURES OF NETTI *AdaptPro*

STANDARD

SEAT

- Netti Sit cushion Cushion with good pressure distributing properties
- Tilt – 3° to + 30°
- Adjustable height 415 mm to 445 mm by change of wheel size and position
- Adjustable depth from 355 – 505 mm

WHEELS*

- 24" x 1" PU main wheels with quick release axle and drum brake
- Push rim: Aluminium
- 7" Puncture proof front castors with quick release axle

Standard main wheels may vary between countries.

* **Crossbar for increased frame stability.**

PUSH BOW

- Height adjustable, swingable

BRAKES

- Attendant and user drum brakes

ANTI-TIP

- Automatic following the main wheel position
SW 300 – 400 low anti-tip, 450 – 500 high anti-tip

BACKREST – NETTI SMART

- Angle: 86° – 133°
- Height: 500 mm
- Backrest extension integrated in the back (See chapter 5)
- Backrest cushion with integrated lumbar support and side support, height adjustable

LEG SUPPORT

- Grandis angle adjustable leg supports, swingable, removable
- Height and angle adjustable foot plates
- Calf supports and knee upholstery

ARM SUPPORT

- Height adjustable
- Swing away
- Depth adjustable pads

OPTIONS / ACCESSORIES

SEAT

- Trays & reading stand for trays (See chapter 5)
- Hip belts and 4 point belts harnesses (See chapter 5)
- Abduction block

WHEELS

- 16" Puncture proof wheels with drum brake and frame extender with height adjustment
- Pneumatic front castors (See chapter 5)
- Spoke protectors (See chapter 5)
- Frame extender – increased stability
- Sideway stabilizer
- Push rims (See chapter 5)

BACKREST

- Backrest cushions – different models
- Side support correction
- Free back cylinder inclusive Evoflex hip belt
- H-belt attachment rack
- Pelvic Stabilizer

LEG SUPPORTS

- Angle adjustable
- Grandis fixed angle
- Universal leg support
- Dynamic leg supports DUAL

ARM SUPPORT

- Different pads (See chapter 5)
- Hemi armrest and Hemi cushion (See chapter 5)

NETTI HEAD SUPPORTS

- Height, depth and angle adjustable – several models
- Removable
- Dynamic function on Dynamic head support

4.1 ACCESSORIES

i The anytime updated complete accessory program is found on our web page www.My-Netti.com

i Not all accessories are available for all wheelchair configurations. Please check the homepage or ask customer service for further details.

BELTS

Several models:
Hip belts with or without upholstery and with plastic lock or car lock.



H-BELT ATTACHMENT RACK

To be mounted on to the push bow brackets.



TRAYS

3 models:
Swingable, lockable and standard "push on". To be used with care as the table follows the arm pads which swing with the chair back.



UPHOLSTERY FOR TRAY

Offers a soft base for the arm resting on the tray.



WEDGE

Increases side support.

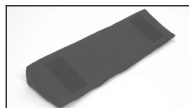

LUMBAR SUPPORT

Increases lumbar curvature.



BACKREST CUSHIONS

Many to choose from. Please contact your dealer.



SEAT CUSHIONS

Many to choose from. Please contact your dealer.



LEG SUPPORTS:

Grandis angle adjustable



Grandis fixed angle

Adjustable in fixed positions between 33° to 105° using an Allen-key.

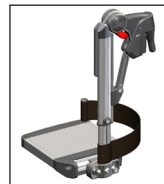

Grandis extension piece

Required for mounting of any Grandis leg supports.



Universal leg support



Angle adjustable leg support



ABDUCTION BLOCK

The block reduces abduction.

Small: 80 mm width
 Medium 110 mm width
 Large: 140 mm width

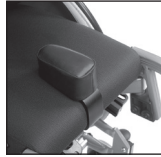

HEAD SUPPORTS

Support A Side support also available with forehead strap

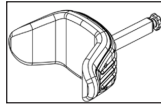

Support B small

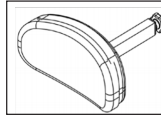

Support C large

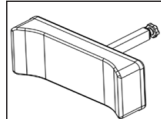

Support D comfort pressure distributive

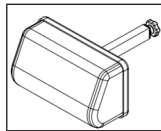

Support E adjustable side supports

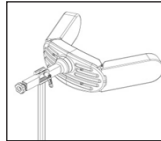

Support F with cheek / chin support band

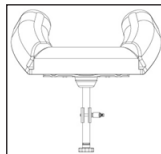

Support Relaxo



HEAD CUSHION

400 x 400 mm cushion with Kospoflex filling and rubber.



HEAD CUSHION COMFORT

Cushion with Kospoflex filling to pull onto head rest.



HYGIENE COVER

Protects the core of the head support.



HEMI CUSHION

A more accommodating support than the hemi arm support.



ARM SUPPORT PADS

Wide: 385 x 58 mm

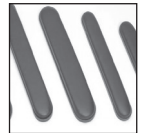

SIDE SUPPORT CORRECTION

Meant for correction of unfavourable postures in the upper trunk.

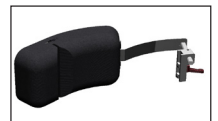

SIDE SUPORT STABIL

FOOT BOARD WITH LOCK

The leg supports can be swung to the side like standard leg supports.



SPOKE PROTECTORS

For 24".
Black or transparent is optional.



UPHOLSTERY FOR CALF SUPPORT BRACKET

Reduces pressure.



PUSH RIMS

Aluminium: 24"

Friction push rim 24"

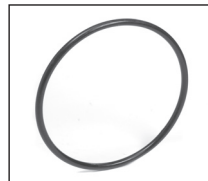

FRAME CROSS BAR

Increased sideways stability

TOOL SET



MAIN WHEELS

available in sizes:
16" with drum brake
24" with drum brake.
Puncture proof Flexel or PU.



Wheel frame extender
60mm rearward position
for the main 24" wheels.



Wheel frame extender
for rearward and height
adjustment 16" main wheels

FRONT WHEELS / CASTORS

available in sizes: 7"

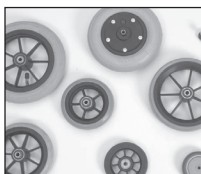

5. ASSEMBLING AND ADJUSTMENT



5.1 UNPACKING

(See chapter 5 & 6 for details for mounting)

1. Unpack all the parts, and check that everything is delivered according to the packing list.
2. Mount main wheels and front castors.
3. Mount backrest, arm supports, cushions and leg supports.
4. Mount accessories.

Weight of components (450 mm chair width):

Drive wheels:	1.7 kg each
Front castors:	0.9 kg each
Leg support Grandis left.:	2.8 kg
Leg support Grandis right:	2.1 kg
Netti Smart Back:	1.4 kg
Netti Sit:	1.0 kg



Necessary tools are described under each chapter.



Accessories described in chapter 4 are a presentation of options, and will be delivered with separate mounting descriptions.



When seating and wheel adjustments are done in the possible positions by standard equipment, the adjustments will not exceed safe limits.

5.2 INITIAL ADJUSTMENTS TO THE USER – OVERVIEW

Start with user sitting in a normal upright position.

SEAT ADJUSTMENTS – BALANCING THE CHAIR

It is vital to adjust the seat correct. Adjustments to the seat change the centre of gravity which effects the balance of the wheelchair. Proper adjusted seat provide stability and the ability to manoeuvre the wheelchair, even during a max extension of the dynamic parts of the wheelchair.

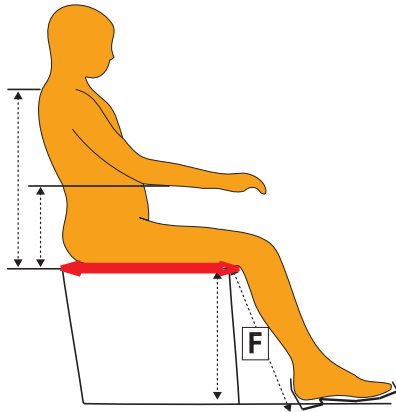

Correct seat depth depends on the user's thigh length and is measured while seating – see the red horizontal arrow on the illustration.

- Seat depth can be adjusted on the back of the chair by moving the back brackets followed by adjusting the back cylinder position.
- Seat depth can be adjusted on the middle of the chair by extending or shortening the seat plate.
- Seat depth can be adjusted in the front by adjusting the position for the front of the seat plate.

The extension pieces where the leg supports are mounted, can in addition be positioned more forward for adjusting to unequal long legs.



The relationship between seat angle and backrest angle should be kept constant when the tilt function is used to create variation for the user.

- Seat height is to be seen together with the leg supports and with the wheel positions.
- Leg supports need to be adjusted to accommodate the seat height.



Please note: the Netti leg support adjustments are described in detail in chapter 5.10.



Please, see the drawings on next page regarding seat depth adjustments.

5.3 WHEELS ASSEMBLING

5.3.1 DRIVE WHEELS

To mount the drive wheel remove the quick release bolt from the hub bushing, lead it through the centre of the main wheel and into the hub bushing while pressing the knob in centre of the quick release.



i Sand and sea water (salt used for gritting in the winter) can damage the bearings of the main wheels. Clean the wheelchair thoroughly after exposure.

There are following wheels available: 16" and 24". Choice of main wheel size and position in the wheel bracket allows for driving characteristics – self drive or attendant drive and seat height adjustments. Both 24" wheels and 16" wheels have drum brakes.

i Choice of wheel size and position requires adjustments of the front castor stem angle.

i To check that the drive wheel is properly attached to the hub, remove the finger from the central knob and pull the main wheel.

⚠ If the drive wheel does not lock, see chapter 5.3.6 and adjust. If it still does not lock, do not use the wheelchair but contact your dealer.

5.3.2 FRONT FORK

Front forks come as standard with quick release axles. The front fork is easily removed by pressing the quick release button on top of the bearing house.

5.3.3 FRONT CASTORS

Removal

- Press the release button on top of the front fork bearing house – by pressing on the silicon cap covering the release button.

Mounting

- Lead the quick release axle into the bearing house and into the front fork.
- Pull the fork slightly to ensure that the fork is fully locked.



Sand and sea water (salt used for gritting in the winter) can damage the bearings of the front castors. Clean the wheelchair thoroughly after exposure.

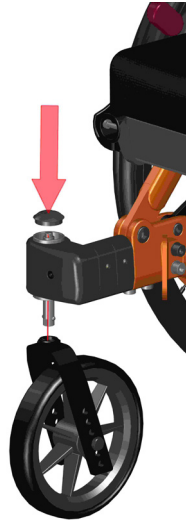

5.3.4 FRONT CASTOR BEARING HOUSE DEPTH ADJUSTMENT

The front castor bearing house position can be adjusted changing the distance between the front castors and the main wheels.

The max. adjustment range is 75 mm.

- Remove the covers over the front castor bearing house extension tube.
- Unscrew the 2 screws holding the extension tube from below.
- Position to the desired front castor bearing house depth.



Make sure that both vertical screws are engaged into the extension tube.

- Tighten the vertical main screws firmly.
- Replace the covers.

If the depth has been increased, you need one pair of additional covers. If the depth has been reduced you have one cover pair in spare.

- Repeat on the other side.

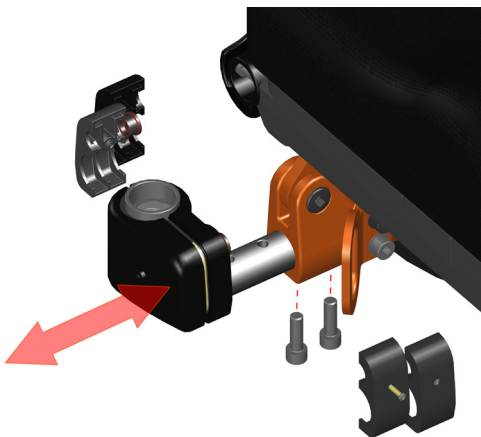

5.3.5 CORRECT FRAME ANGLE

To ensure good driving characteristics you need to check and adjust – with drive wheels and front castors mounted – that the lower frame is horizontal and the front castor bearing house is vertical. See dotted red lines.

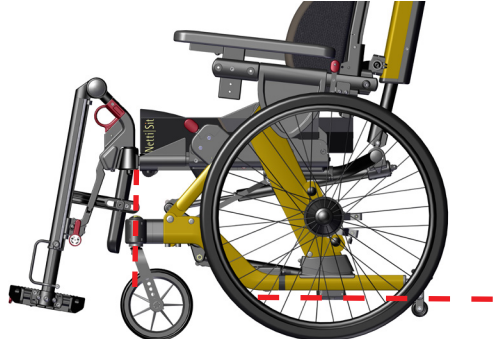

ADJUSTMENT OF THE ANGLE OF BEARING HOUSE:

- Unfix the screw in the front of the bearing house cover and remove the cover.
- Loosen the 2 screws clamping the bearing house and move the bearing house up or down until it has 90 degree angle to the level ground when the wheelchair is standing on all 4 wheels.
- If necessary to get the bearing house easier moveable, you can slightly screw the middle set screw inward. This will open the bearing house clamping and ease the height adjustment.
- Screw the set screw outward before.
- Tightening the 2 bearing house clamping screws.
- Replace the cover.
- Repeat on the other side.

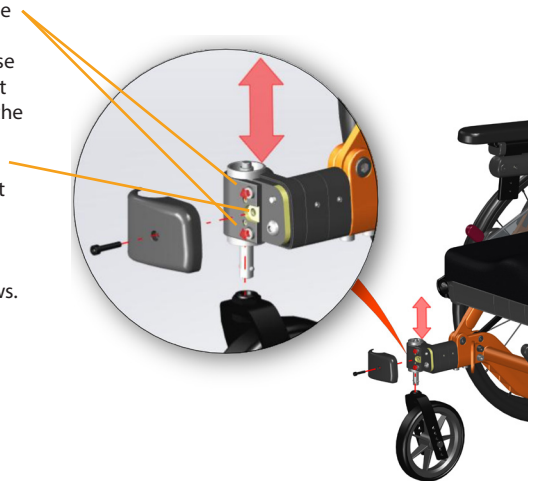

 **Check angle of castor bearing house.**

 **1 pc 5 mm Allen-key.**

5.3.6 MAIN WHEEL QUICK RELEASE

The quick release axle links wheel and frame.
The nut sitting under the head of the quick release axle can be adjusted to fit the axle tightly when inserted into the frame.
Adjust the nut backwards towards the axle head if the axle does not click in.
Adjust the nut forwards if the axle sits loose when inserted through wheel and brake.



5.3.7 DRUM BRAKE ADJUSTMENT

The wheelchair is fitted with hand operated drum brakes.

If the brake does not brake properly:

Adjust the wire on one or both sides, adjust the foot screw 2–4 rounds out. Then re-check the brakes.

If the wire is too loose:

Adjust the foot screw all the way in. Tighten the wire by loosening the wire clamp before pulling the wire further through it. Tighten the wire clamp, and adjust the foot screw out again



1 pc 10 mm open-end spanner.

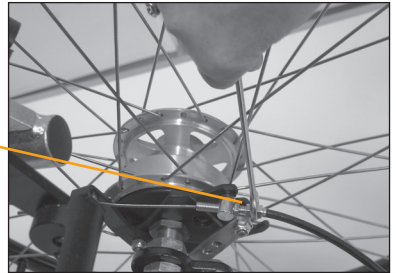

To ensure the correct functions of the wire, these must never be taut.

5.3.8 OPERATING THE BRAKES

Operating and applying the attendant brake

The wheelchair is fitted with hand-operated hub brake handles for the drum brakes, to allow regulation of speed on hills and whilst travelling along. These are located on the push bow.

- **To apply the brakes, pull the brake levers (1) evenly and smoothly towards handle and bring the wheel chair to a stop.**
- **The parking brake is at the same time the user brake.**

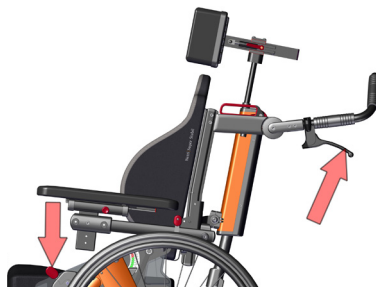

Operating and applying the user brake / parking brake

The wheelchair is fitted with hand operated user parking brake, one on each sides. The user brake activates the same drum brake as the attendant brake.

- To activate the parking brake: push the handles on both sides, forward.
- To release the brakes: lift the handles up.

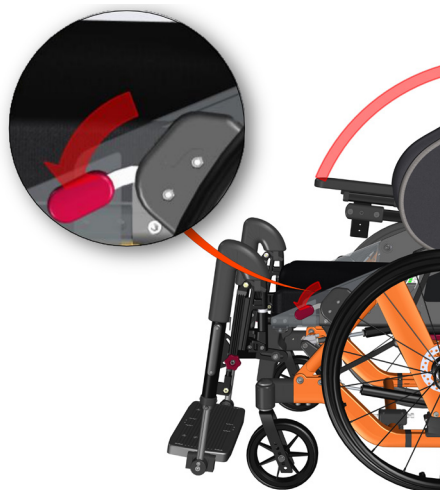

- ⚠ The user brakes cannot be used as running brakes.
- ⚠ Do not leave the user in the wheelchair without activating the parking brake.

5.4 SEAT ASSEMBLING – WHEELCHAIR SEAT HEIGHT

Choosing the seat height is a combination of identified Intended use (tripling or only driving) and the sized of the user (leg length).

5.4.1 SEAT HEIGHT – WHEEL POSITIONS

The seat height depends on:

- The size of the **main driving wheels**.
- The position of the driving wheels in the main wheel brackets on the frame.
See lower illustration on next page.
- Size of **front castors**.
- Position of front castors in the front fork.
- Size of front fork.
- Height of front fork in the front fork bearing house.

By repositioning the main wheels in the brackets there are 2 seat height available; starting from seat height 417 mm with 24" main wheels, you can increase the seat height to 447 mm.

5.4.2 SEAT HEIGHT AT THE REAR

The seat height at the rear depends on:

- Size of the main wheels.
- Position of main wheels.

MAIN WHEEL:

Loosen the hub bushing, including washer and nut, and mount it in required position in the main wheel bracket. The disc brake dolly must be positioned in the hole lower than the wheel bushing.



2 pcs 24 mm open-end spanner.



Make sure that the nut on inside of frame totally wreathes the wheel bushing.



When the seat height is changed make sure that the bearing house of the front castors are adjusted vertical to the ground.



The risk for tipping increases when the main wheel is moved forward in the main wheel bracket.



Check the position of anti-tip.



Readjust the brakes (See chapter 5.3.6).



The *AdaptPro* frame is fitted with anti-tips which automatically follow the position of the main wheels. The anti-tips are delivered adjusted according to ordered main wheel size and standard position.



MAIN WHEEL EXTENDER:

Users with large rearwards extension movement patterns, may benefit from increased wheel footprint for even more initial stability.

Wheel extension brackets are available to be mounted to the main wheel bracket – extending the wheelbase footprint with 60 mm.

- Remove the wheel hub.
- Mount the extender in its place.



1 pc 16 mm and
1 pc 17 mm open-end spanner.

- Mount the wheel hub to the extender.

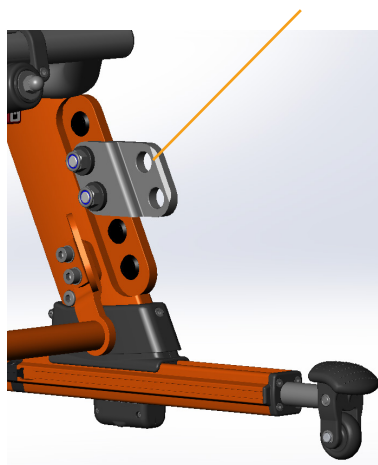

Always check the anti-tip height. It may be necessary to ad an extension unit to the anti-tip wheel to get desired distance from the ground – around 30 mm.

5.4.3 SEAT HEIGHT AT THE FRONT

The seat height in the front depends on:

- Size of front castors.
- Size of front fork.
- In chapter 4.2 the overview shows that you can choose between 2 models of front castors 6" and 7" (standard) and front forks.
- To change the height of the front castors – loosen the wheel from the front fork and replace its axle in the required position.



2 pcs 13 mm open-end spanner.



Always check and adjust the angle of the front fork bearing house after changing front castor model and / or position. See chapter 5.3.5.



5.4.4 NETTI SEAT PLATE

The Netti Seat plate is an advanced seating platform developed to give persons sitting long time, improved comfort and reduction of seating problems.

- The lowered surface under the sitting bone area allows for reduced pressure under the sitting bones.
- The sloping edge from the lower to higher seat plate area provides a sliding limiter for the sitting bone, reducing sliding.
- The possibility for seat plate depth adjustment allows for correct positioning of the pressure releasing lowered area and ensures good support under the thighs.
- The perforated surface allows for ventilation – reduced moisture.

SEAT DEPTH ADJUSTMENTS:

The seat depth can be adjusted in several positions and in 3 different places:

- At the rear, by moving the chair back hinge – 2 positions.
- At the middle of the seat plate – by pulling out the rear part of the chair plate, extending the seat plate itself.
- At the front by changing the position of the seat plate in the seat frame.

In addition the leg support extension pieces can be moved forward protruding at the front of the seat plate.

Adjustments are done to give the user a comfortable seating position with proper lumbar support while the knee joint is aligned with the leg support knee joint and to ensure that the sitting bones are correctly placed on the seat plate.

By adjusting the seat depth, the chair balance and the driving characteristics may change. A well balanced chair is easy to drive without easily tipping backwards.



Please make a careful assessment of how the seat depth adjustments most favourable shall be made to keep good balance in the wheelchair.

When seat depth adjustment is required, the position of the seat plate must also be adjusted to ensure good lumbar support and still keep alignment of the leg support knee joint to the user knee joint.

The seat plate depth is delivered as a standard following the seat width as shown in the table.

Chair width	Seat depth standard	Seat depth range
350 mm	380 mm *	380 – 455 mm
380 mm	405 mm *	380 – 455 mm
400 mm	405 mm	380 – 455 mm
430 mm	455 mm	430 – 505 mm
450 mm	480 mm	430 – 505 mm

* With the back moved 25 mm forward.

5.4.5 SEAT DEPTH – ADJUSTING AT THE REAR

Adjusting seat depth at the rear by moving the back hinge point:

The backrest hinge has 2 possible positions with 25 mm distance between them, allowing for moving the back and thereby changing the seat depth – that is changing the distance from seat plate front to the chair back.

- Loosen the hinge screws on both sides and fix the back in the desired position.



2 pcs 6 mm Allen-key.

Adjust the back cylinder position after the back hinge is moved.

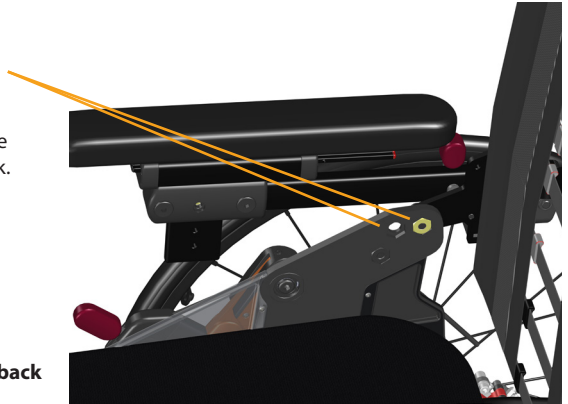

5.4.6 SEAT DEPTH – ADJUSTING THE SEAT PLATE LENGTH AT THE SEAT PLATE MIDDLE

Tilt the seat plate extra high to get access to the screw from the side, as shown on the illustration.

The seat plate depth is adjusted by removing the long fixing bolt crossing through the seat plate, and pulling or pushing the rear part of the seat plate to desired depth.



2 pcs 5 mm Allen-key.

SEAT PLATE DEPTH SCALE:

The seat plate a scale shows which seat depth has been chosen.

With the chair-back moved to forward position the seat depth is 25 mm shorter than what the scale shows.

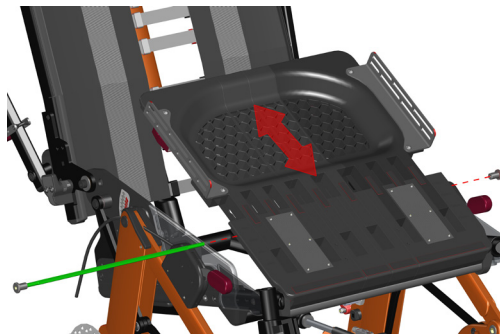

5.4.7 SEAT DEPTH – ADJUSTING AT THE SEAT PLATE POSITION IN THE FRONT

The seat plate depth can be adjusted by pulling the rear half backwards as described in the previous chapter.

When the seat plate depth has been changed, its position on the seat frame must be adjusted to ensure that the seat plate fits correctly. The rear part of the seat plate shall refer to the back Velcro.

TO ADJUST THE SEAT PLATE POSITION:

- Tilt the wheelchair as far backwards as possible to get access to the side of the seat frame
- Remove the front cloth protection by unscrewing the screw sitting underneath the cover.
- Remove the rear set of 2 screws (on each side) shown in green.
- Pull out the seat plate with the leg support extensions and fix when desired seat plate front position is reached.



1 pcs 5 mm Allen-key.



By using the Velcro adjustment straps in the chair-back you can gain some mm on the depth.

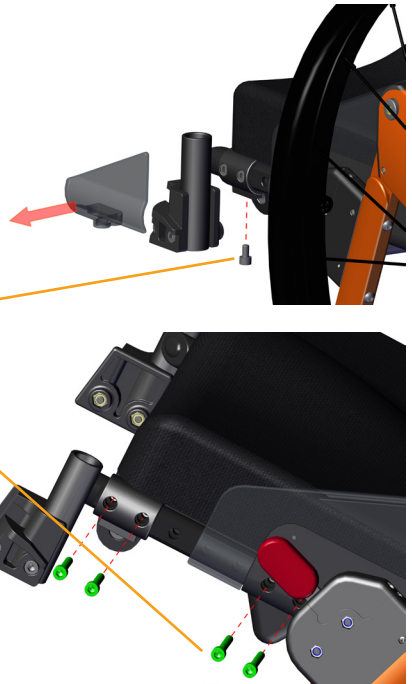

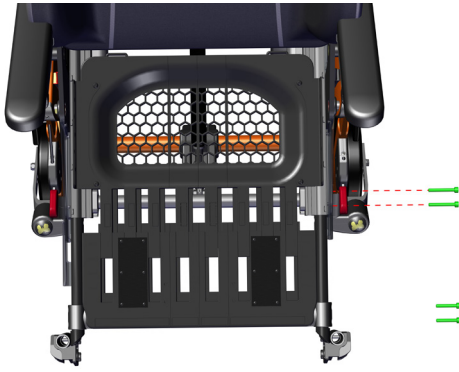

Adjusting leg support extension pieces allow for adjusting for knee joints not being aligned with the leg support knee joint.

- Remove the front cloth protection by unscrewing the screw sitting underneath the cover.
- Loosen the 4 screws holding the extension piece for the leg support.
- Set the extension piece to the required position.
- Fix the screws, tighten them with 25 Nm.

By restless users, the extension piece should not be pulled out more than 50 mm.



By setting the extension pieces at different positions, it is possible to compensate for a rotated pelvis or different length of thighs.



1 pc 5 mm Allen-key.

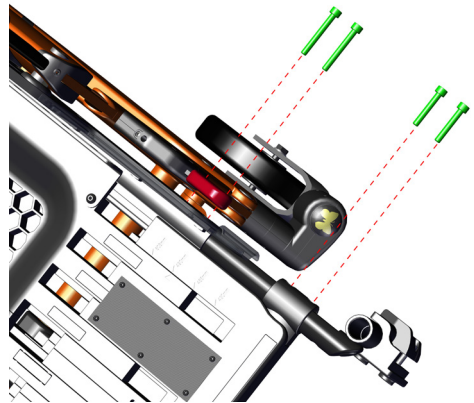

5.4.8 FIXED SEAT PLATE

The seat plate is locked with brackets under the seat plate at the rear.

When adjusting the seat plate length it is necessary to unfix the seat plate by loosening the brackets. Swing the seat plate up to get access to the screws for changing seat plate length as shown in chapter 5.4.6.

5.5 CHAIR BACK ASSEMBLING AND POSITIONING

TO MOUNT THE RECLINE GAS SPRING:

- Lift the backrest by its push bow with one hand,
- Lead the gas spring locking head into the covered steel bracket which is sitting on the lower cross beam at the rear.
- Secure the backrest by pushing the locking bolt in from the side, through the bracket and gas spring locking head.

i To check that the backrest is locked, grip the push bow and press the backrest forward.

i If the backrest falls forward – repeat the locking procedure or contact your dealer.



5.5.1 ADJUSTING THE VELCRO BACK

- Loosen the straps, and place the backrest cushion so that user gets room for the bottom and the integrated lumbar support in correct position.
- Tighten the straps so that they follow the curvature of the spine and give a little extra support at the top of the sacrum.

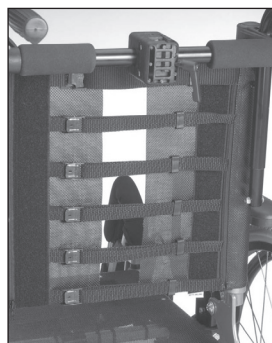

REPLACEMENT OF THE VELCRO BACK:

In case the velcro back needs to be replaced, the back extender is to be removed – see 5.5.3 next page.

- Remove the back profile top cap.
- Loosen the M4 x 8 mm set screw holding the Velcro – placed on the top inside of the back tube.
- Slide the Velcro up and out of the back profile.
- Mount the new Velcro by sliding it – with plastic rods – into the chair-back profiles.
- Insert the set screw to hold the Velcro in place in the height.
- Mount the back extender.

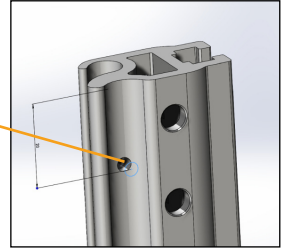

5.5.2 PLACING BACK SUPPORT CUSHION

The back support cushion are fixed and adjusted on the wheelchair using the back Velcro.



It is imperative to correctly set-up the seat and the back cushions in order to ensure good seating comfort.



The cushion covers are washable and thereby reusable. Follow the instruction on the back of the cushion for correct maintenance and washing of the cushion.



5.5.3 BACK EXTENDER

The back height of Netti *AdaptPro* is 510 mm measured from the seat plate to the top of the back Velcro. For users taller than around 1.85 m it may be advantageous to have a higher back for better support around the shoulder region.

Netti *AdaptPro* is prepared for back extender allowing for increasing of the back height with up to 115 mm. To be ordered as accessory.

The back extender is mounted by fixing the back extender profiles to the inner side of the chair back tubes with 2 pcs screws on each side.

Back extender height adjustment:

- Loosen the screws slightly and slide the extender profiles up to desired height, tighten well.



1 pc 5 mm Allen-key.

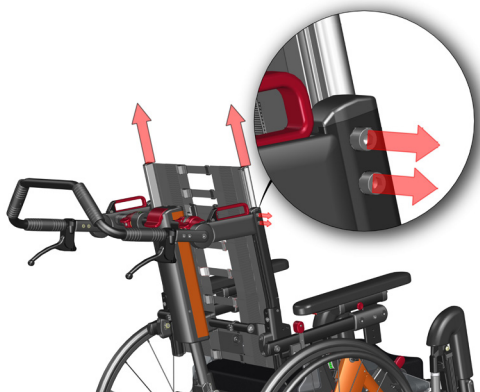

5.6. ASSESSMENT AND CHOICE OF BACK SUPPORT CYLINDER

The chair back position is defined by the chair back cylinder. There are different cylinder strength available for the Netti *AdaptPro*:

INDICATIVE correlation between body weight and suitable recline gas spring force:

450 N gas cylinder – 65 kg user weight

600 N gas cylinder – 80 kg user weight.

Please contact your dealer if you need other strength.

5.6.1 CHANGE OF RECLINE GAS CYLINDER

- Remove back cushion and fold up the arm supports.
- Remove the back cylinder splint.
- Fold the chair-back forward.

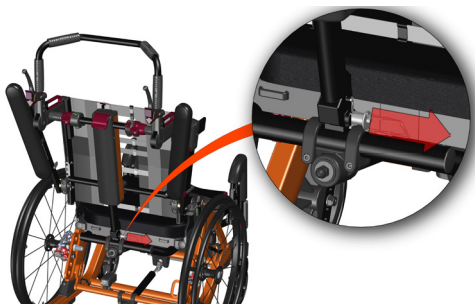

- Remove the back cylinder cover by unscrewing the 4 screws – shown green in the illustration.

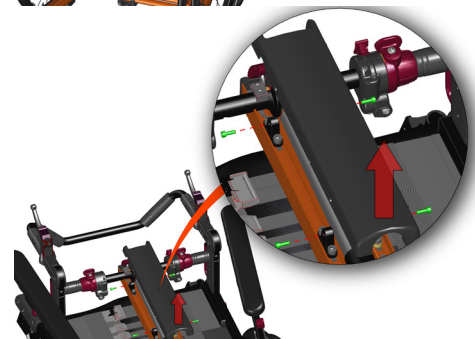

 **1 pc 3 mm Allen-key.**

- Unhook the wires attached to the cylinder head.

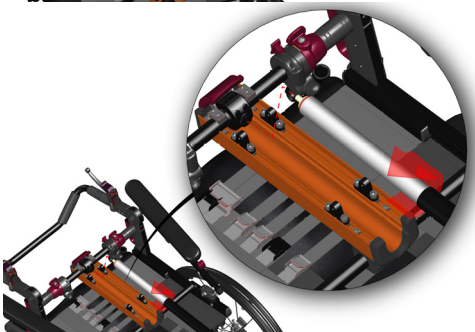

- Remove the cylinder by unscrewing it from the cylinder head.

- Replace the cylinder with a new – with correct strength for the user.
- Mount all parts that was removed.
- Adjust the wires.
- Fold up the chair-back and test if the solution suits the user strength, and bring the user back to upright position when his/her extension movement ends.

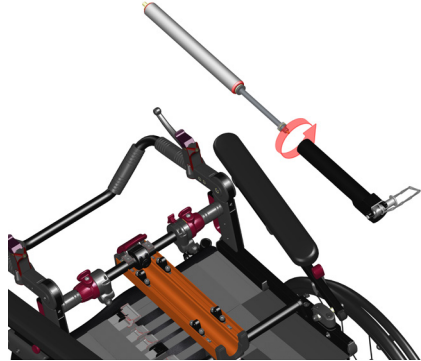

- Fold up the chair-back and fix it with the bolt.
- Test if the new gas cylinder strength suits the user strength and is strong enough to calmly bring the user back to upright position when his / her extension movement ends.



5.6.2 CHANGE OF TILT GAS CYLINDER

The Netti *AdaptPro* is equipped with 2 tilt gas cylinders. The upper cylinder is the one taking much load. The lower is supportive to the upper cylinder. Both cylinder can easily be replaced in the same manner:

- Unscrew the 2 M5 screws holding the rear gas cylinder bracket and push the 2 U-shaped brackets sideways.

 **1 pc 4 mm Allen-key.**

- Fold the gas cylinder down.
- Unscrew the gas cylinder heads on both ends of the gas cylinder.
- Replace the gas cylinder and reverse the operation.

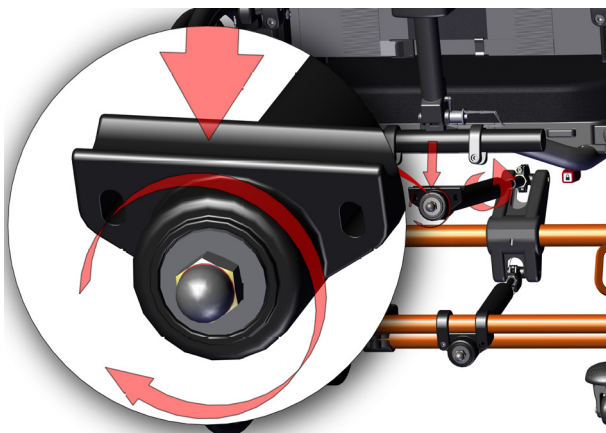
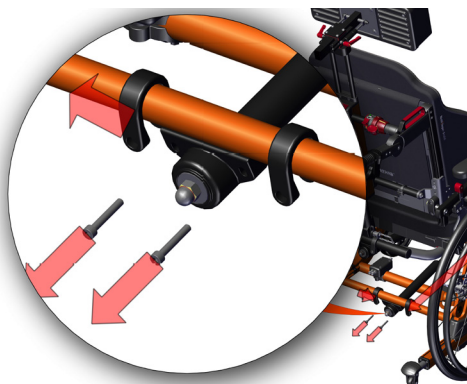

5.7 NETTI HEAD SUPPORT ASSEMBLING AND POSITIONING

5.7.1 NETTI HEAD SUPPORTS

MOUNTING AND REMOVING:

- To mount the Netti head support, lift up the red handle on top of the back gas cylinder.
- Insert the 2 head support rods into the top.
- Fix at any desired height by pushing the handle down.

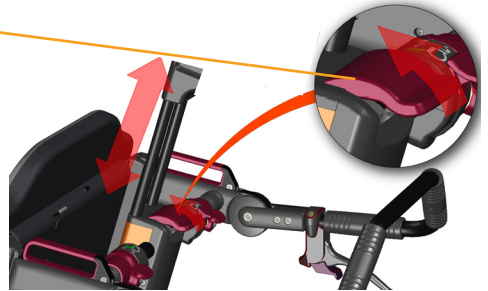

HEIGHT ADJUSTMENT OF THE HEAD SUPPORT:

The middle of the head support cushion shall be positioned to meet the head slightly lower than the most rearward part of the head.

- Open the handle holding the 2 vertical poles of the head support.
- Pull the head support up or down to desired height and close the handle by pushing down.
- A plastic rectangular stopper is mounted to the vertical bars to help find the same height every time when replacing the head support.

When the correct height is defined, push the stopper down till it meets the top of the gas cylinder house. Fix it by tightening the screws holding it positioned to the 2 vertical bars.

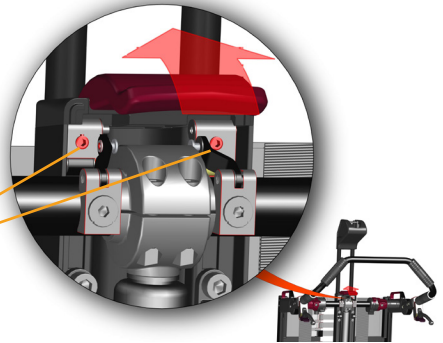

HANDLE ADJUSTMENT:

The main handle can be adjusted to keep its tightness holding the head support stable.

- Remove the gas cylinder cover to get access to the 2 screws shown on the picture.
- Tighten or loosen according to the need.

5.7.2 NETTI DYNAMIC HEAD SUPPORT ADJUSTMENTS

The Netti *AdaptPro* can be equipped with a Netti dynamic head support. The head support follows the backward movement of the head when the head is pressed against it.

A small cylinder dampens the movement and brings the head back to normal position after extension.

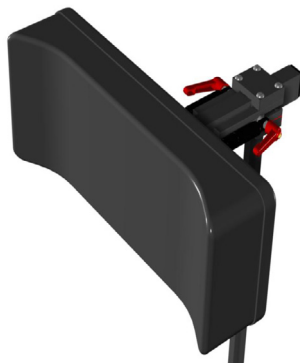

DEPTH ADJUSTMENT:

- Unlock the two red levers, one on each side of the head support horizontal tube.
- Move the head support forwards or backwards to desired position.
- Fix the two levers firmly.

5.7.3 NETTI PUSH BOW TIGHTENING

The push bow may start to lose its position after the chair has been used for some time. Then the push bow holding mechanism needs to be tightened.

- Loosen the M4 set screw
- Tighten the M5 screw sitting underneath
- Fold the handle down and check if it is harder to operate. Tighten the set screw.
- Repeat on the other side if needed.
- Test if the push bow now holds the position when handled.

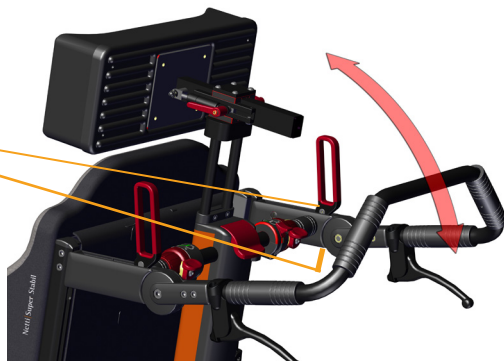

- 1 pc 2 mm Allen-key
- 1 pc 4 mm Allen-key.

5.8 ARM SUPPORTS ADJUSTING

5.8.1 ARM SUPPORTS HEIGHT – AT THE FRONT

Adjust the arm support height to fit the user. The height should give good underarm support without lifting the shoulder. There are 4 height positions available, with 18 mm distance between each.

- Unscrew and position the arm support in correct height for the user.



1 pc 5 mm Allen-key.

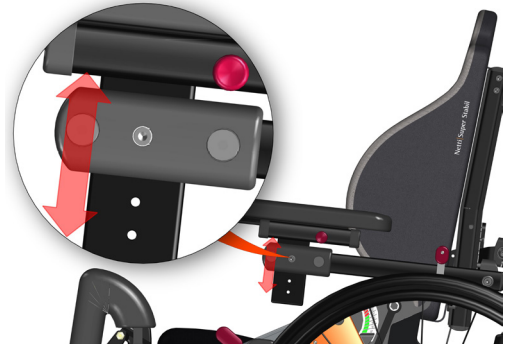

5.8.2 ARM SUPPORTS HEIGHT – AT THE REAR

If the adjustments at the front of the arm support is not giving you enough height, please reposition the arm support at the rear end.

There are 2 heights available with 58 mm distance.

- Unscrew and position the arm support in desired height.
- From the new rear arm support position, fine adjustments can be performed at the front.



1 pc 6 mm Allen-key.



5.8.3 ARM SUPPORTS HANDLING

The arm support is hinged at the wheelchair back support frame. To stay stable when in use, a lock is fixing it in its horizontal position.

The lock is easily pushed slightly backwards and the arm support can be swung up.

When folding down, the arm support clicks into lock by itself.



When the arm support is swung up there is free space for side transfer.

With the arm supports swung up there is good access to place sails etc. behind the back of the user.



Always lock the brakes when you plan for actions and swing the arm support up.

5.9 BELTS AND HARNESES

MOUNTING, POSITIONING AND ADJUSTMENTS OF PELVIC SUPPORTS AND SUPPORTIVE HARNESES:

Netti *AdaptPro* is prepared for mounting several different types of pelvic stabilizer and supportive harnesses, each type developed to give the user the best stabilization support depending on the conditions.

AVAILABLE BELTS AND HARNESES:

- Pelvic stabilizer
- Upper body harnesses
- Ankle huggers
- Shoe shells

PELVIC STABILIZER:

Mounted to the seat plate, helps the user to keep his / her position on the seat even when he / she is sitting quite restless.

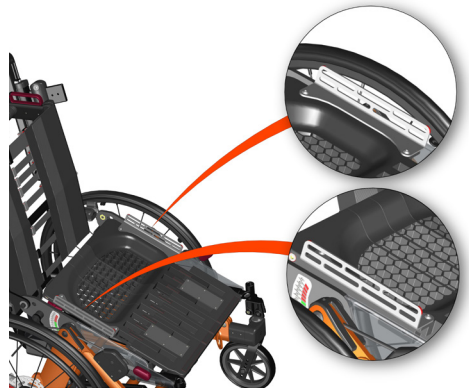

HOW TO ADJUST THE PELVIC STABILIZER:

The pelvic stabilizer is mounted on the belt fixing brackets on the seating plate as shown on the illustration.

- Slide the pelvic stabilizer to a position where it crosses the upper thighs, angle: 70 – 90 degrees.
- Adjust the pelvic stabilizer / belt mounting point for the belt to be tightened.
- Remember to shorten the stabilizer beneath the last used hole to avoid any conflict with chair frame.

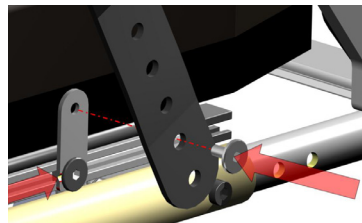

 A pelvic stabilization belt must always be used when using upper body harness.

The seat plate is prepared with mounting loops on its rear end for fixing the 2 rear belts of the 4-point pelvic stabilizer.

H-BELT RACK FOR UPPER BODY HARNESS:

Upper body harness rail is mounted to the chair-back profiles by separate brackets. See separate Mounting Description for upper body harnesses at: www.bodypoint.com

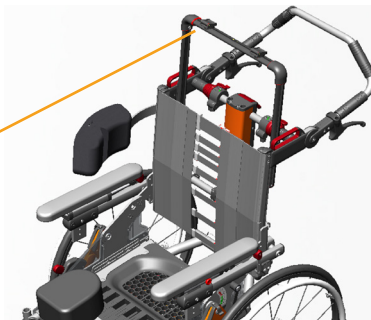

ANKLE HUGGERS AND SHOE SHELLS:

Helps to keep the feet on the foot board not letting them slide of during use.

The ankle huggers are mounted by threading them through the slots in the foot board on the leg support and fixing the belt on the underside of the foot plate, threading shown in the illustration – follow the numbers.

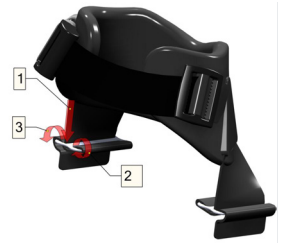



BELTS AND HARNESES for Netti Dynamic System	Article number	Description	Pictures
BELTS / STABILIZERS			
Pelvic Stabilizer Evoflex M	82788	Medium	
Pelvic Stabilizer Evoflex L	82789	Large	
4-point belt padded M	45013	Medium	
4-point belt padded L	45014	Large	
HARNESSES			
Chest support Stayflex w/o Zipper	45015	Medium	
Chest support Stayflex w/o Zipper	45016	Large	
Belt shoulder harness Pivotfit M	45017	Medium unisex	
Belt shoulder harness Pivotfit L	45018	Large unisex	
LOWER EXTREMITIES			
Calf support pad	45019	Medium	
Calf support pad	45020	Large	
Ankle-Huggers S	44863	Small 170 - 200 mm	
Ankle-Huggers M	44864	Medium 190 - 230 mm	
Ankle-Huggers L	44865	Large 220 - 290 mm	
Ankle-Huggers XL	44904	Extra large 280 - 330 mm	

For complete and updated overview, please see our homepage – product catalogue – www.My-Netti.com

5.10 LEG SUPPORTS

Netti AdaptPro is as a standard delivered with Netti Grandis leg supports.

The chair can also be equipped with following alternative leg supports:

- Grandis leg support
- Universal leg support
- Angle adjustable leg support standard
- DUAL dynamic leg supports
- Amputation leg support.

5.10.1 LEG SUPPORT HEIGHT AND LENGTH ADJUSTMENTS

Leg support adjustment takes place in 2 directions. First adjustment is the foot board height and the second adjusting the seat plate depth. The goal is having the leg support knee joint and the user knee joint aligned in the same axis.

Measure the user's lower leg length F – 90 degrees bent knee – measure from underside thigh to the underside heel of normal used shoe.

The knee joint of the leg support may be hidden under the knee upholstery. Adjust the foot board height according to the lower leg length measured.

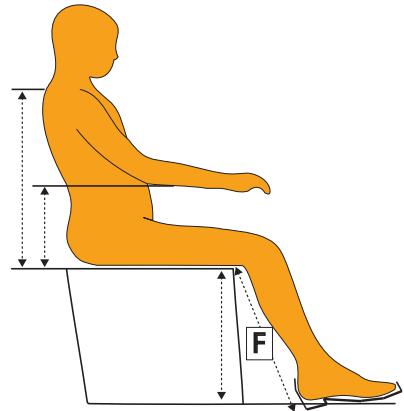

 Make sure there is enough free space under the foot-board for the wheelchair to pass minor obstacles.

Slightly tilting the seating unit may help. If not sufficient, the chair height must be adjusted as described in this user manual chapter 5.3.

 **CORRECT SEAT DEPTH:**
Adjust the seat plate and position as described in chapter 5.4.

5.10.2 GRANDIS LEG SUPPORTS

 The Grandis leg supports require Grandis leg support extension brackets.

The leg support Grandis is angle adjustable – from vertical to horizontal position.

- It is swingable and removable.
- It is height adjustable and comes with height and depth adjustable calf support.
- The foot plates are hinged, and can be angled in fixed positions.

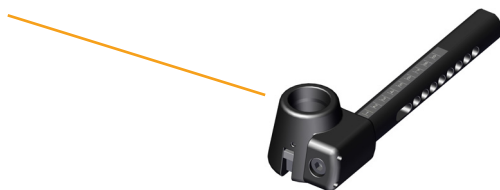

As a standard the foot plates come with a lock connecting the 2 plates. This makes the plates stronger and reduces maintenance. If locking is not wanted, the bolt of the lock can be removed by using an Allen-key.

MOUNTING OF THE GRANDIS LEG SUPPORT:

- Fold the foot plates up.
- Hold the leg support on the top joint, and place the vertical bolt in the leg support fixing bracket on the wheelchair, slightly turned outward.
- Swing the leg support inwards and push slightly downwards until it clicks into locked position.



GRANDIS ANGLE ADJUSTMENT:

To adjust the angle of the leg support simply release the red lever and lift or lower. The leg support will stay in the position where you lock the lever.



GRANDIS FOOT PLATE HEIGHT ADJUSTMENT:

The foot plates are stepless height adjustable.

- Loosen the adjustment screw for the adjustment bar to move freely.
- Slide the foot plate to required height, then tighten the screw well.

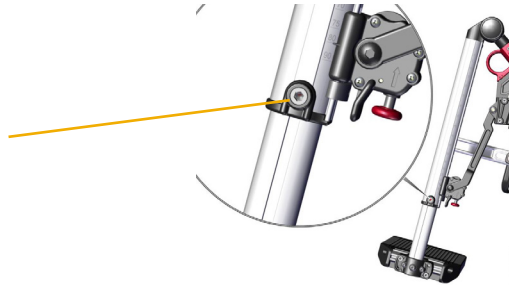

GRANDIS FOOT PLATE ANGLE ADJUSTMENT:

- Unfix the 2 screws as shown below using an 5 mm Allen-key.
- Adjust the foot plate to the required angle and tighten the screws.



GRANDIS FOOT PLATE DEPTH ADJUSTMENT:

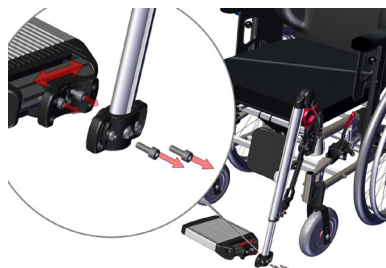

- Unscrew the 2 screws completely as shown below, using an 5 mm Allen-key.
- Pull out the foot plate and loosen the next 2 screw which has become visible.
- Slide the footplate forwards or backwards to desired depth before re-fixing all screws.

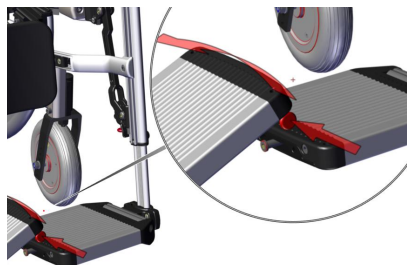

LOCKING AND RELEASING THE FOOT PLATES:

- The foot plates come with a lock connecting the 2 foot plates which makes the plates stronger.
- To lock the foot plates let the right foot plate fall cover the bolt standing out from the left one, it clicks into lock.
- To release the foot plate push the plastic knob under the right foot plate and lift the right foot plate up.



-  **While making the adjustment, there must be no load on the foot plates.**
-  **For outdoor use, there should be a clearance of 40 – 50 mm between the foot plate and the ground.**
-  **When adjusting leg support angle, be aware of squeeze hazard between moving parts.**

REMOVING THE GRANDIS LEG SUPPORT:

- Release the foot plate by pushing the red plastic knob under the right foot plate and lift the right foot plate up.
- Pull the red circular grip on top of the leg support and lift the support upwards while turning it slightly outwards.



GRANDIS CALF SUPPORT ADJUSTMENTS:

The calf support is height and depth adjustable and are to be adjusted in a height and depth that prevents the feet from sliding down from the foot plate.

For chair width 43 – 60 cm where the high version of calf support is used, there are possibility for conflict with heel or seat plate when the leg support is adjusted for short leg length.

To adjust the **height**, loosen the screw on the calf support bracket and slide it into required position before fixing the screw.

 **Make sure to adjust the calf support that they do not conflict with seat plate or foot plates.**

To adjust in **depth** of the calf pad, loosen the screw holding the calf support and slide it to required position before fixing the screw again.

 **5 mm Allen-key.**

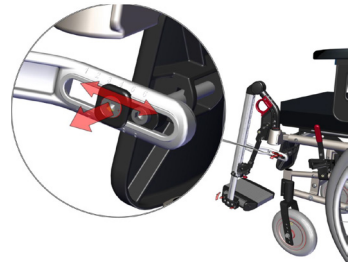

5.10.3 GRANDIS FIXED LEG SUPPORTS



The Grandis fixed leg supports require Grandis leg support extension brackets.

MOUNTING LEG SUPPORT GRANDIS FIXED:

- Fold the foot plates up.
- Hold the leg support in the vertical profile, and place the attachment bolt in the Grandis leg support pull out-piece in an outward angle.
- Swing the leg support inwards and push slightly downwards until it goes into locked position.

TO REMOVE THE LEG SUPPORT:

- Grab around the vertical profile and thereby your hand is lifting the red lock lever.
- Lift up and turn outward.

Grandis Fixed leg support can also be delivered with a foot plate – to be ordered extra.

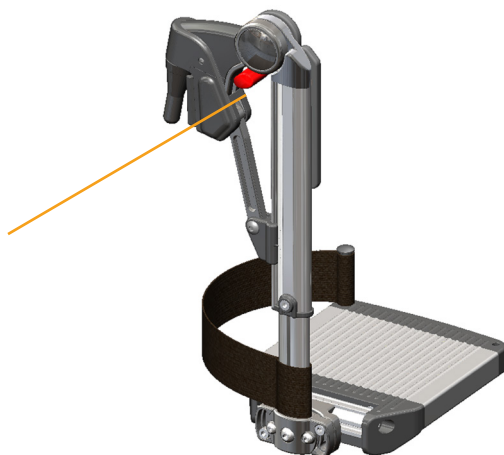

GRANDIS FIXED LEG SUPPORT ADJUSTMENTS:

FIXED ANGLE ADJUSTMENT:

- Loosen the screw on the outside of the vertical profile.
- Swing the leg support to desired angle before tightening and fixing.

FOOT PLATE HEIGHT ADJUSTMENT:

- Loosen the screw on the outside of the vertical profile.
- Move the foot plate (or foot board) to desired height before tightening and fixing.

FOOT PLATE ANGLE ADJUSTMENT:

- Loosen the 2 screws on the outside of the foot plate and rotate to desired angle before fixing.
- Details are also shown in chapter 5.10.2.

 **5 mm Allen-key.**



 **Never stand on the foot plates!**

 **Never lift the wheelchair by the leg supports.**

5.10.4 ANGLE ADJUSTABLE LEG SUPPORTS

The angle adjustable leg supports are swingable, height adjustable and removable. They come with height and depth adjustable calf supports. The foot plates are hinged, and can be angled in fixed positions.

The foot plates come with a lock connecting the 2 plates which makes the plates stronger. If locking is not wanted, the bolt can be removed by using an Allen-key with no loss of functionality.

ANGLE ADJUSTABLE LEG SUPPORT MOUNTING INSTRUCTION:

- Fold the foot plates up.
- Hold the leg support on the top joint, and place it in the leg support bracket on the wheelchair in an outward turned angle as shown in the picture.
- Swing the leg support inwards and push slightly downwards until it goes into locked position.

ANGLE ADJUSTMENT:

- Loosen the star wheel on the outside of the leg support.
- Lift the lower part of the leg support to required angle.
- Tighten the star wheel.



 Be aware of squeeze hazard
between moving parts.

FOOT PLATE HEIGHT ADJUSTMENT:

The foot plates are step less height adjustable.

- Unfix the adjustment screw so that the adjustment bar moves freely.
- Slide the foot plate to required height.
- Tighten the screw.



As an accessory a star knob or a lever handle can replace the screw.

FOOT PLATE ANGLE ADJUSTMENT:

- Loosen the screw on the outside of the foot plate – see picture – with an Allen-key.
- Tilt the foot plate to required angle and tighten the screw.



5 mm Allen-key.

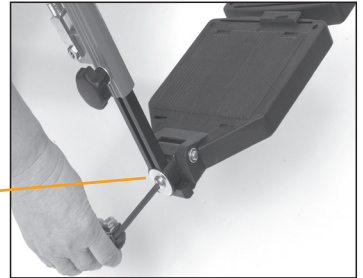

LOCKING AND RELEASING THE FOOT PLATES:

- To lock the foot plates, let the right foot plate fall over the bolt standing out from the left one, it clicks into lock.
- To release the foot plate pull the plastic lock between the foot plates and lift the right foot plate up.

i **While making the adjustment, there must be no load on the foot plates.**

i **For outdoor use, there should be a clearance of 40 – 50 mm between the foot plate and the ground.**



⚠ **Never stand on the foot plates due to the risk of tipping forward.**

CALF SUPPORT ADJUSTMENTS:

The calf supports are height and depth adjustable. The calf supports must be adjusted in a height and depth that prevents the feet from sliding down from the foot plate.

HEIGHT ADJUSTMENT:

Loosen the nut **A** on the calf support bracket and slide it into required position before fixing the screw.



10 mm open-end spanner.

DEPTH ADJUSTMENT:

Loosen the screw **B** between the calf support and bracket and reposition it to required position before fixing the screw.



13 mm Allen-key.

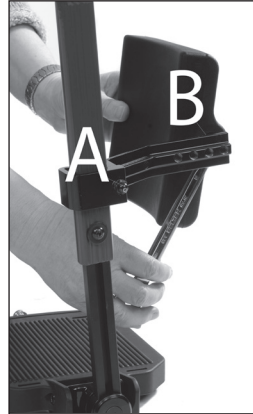

Never stand on the foot plates!



Never lift the wheelchair by the leg supports.

REMOVING THE LEG SUPPORT:

- If there is a foot plate lock, release the foot plate by pulling the red plastic lock between the foot plates.
- Lift the right foot plate up.
- Lift the leg support in the knee joint slightly up.
- Swing it outwards.
- Lift it up.



5.10.5 NETTI DUAL LEG SUPPORTS

NETTI DYNAMIC DUAL FEATURES:

NETTI *AdaptPro* can be delivered with Netti DUAL Dynamic leg support. Netti Dynamic Dual leg support is especial designed for users pushing with uneven force with their lower extremities providing an open kinetic chain. Unilateral extension of the hip (left or right part of the leg support goes down).

The gas cylinders works independent and allows for the leg supports to extended differently – tilting the footboard sideways and also tilting it forwards. This multitude of possible flexible movements – gives the user freedom to perform voluntarily and involuntarily leg movements to very high degree. When the extension forces are reduced, the gas cylinders gently brings the feet and legs back to the original position.

The wear and tear on the wheelchair is substantially reduced since the forces applied, are absorbed by the gas cylinders and flexible system.

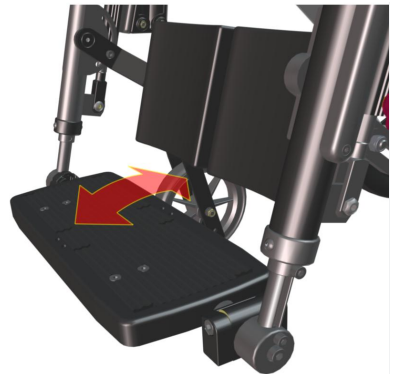

FUNCTIONAL OVERVIEW:

The Netti Dynamic Dual leg supports allow controlled open Kinetic Chain (oKC) movements of the lower extremities of the user. Unlike static wheelchairs, the user's distal segments are supported but can move. This helps to gain control of the proximal segments especially when the user cannot inhibit movements due to their medical condition.

Netti Dynamic system leg support DUAL allows for dynamic:

- Plantar flexion of the feet (foot board pivots anteriorly).
- Unilateral extension of the hip (single leg support goes down).
- Knee extension: (leg supports move forwards).

When tone decrease, the lower extremities will be brought back to neutral position.



Netti Dynamic Dual leg support is offered in 2 different lengths.

Netti Dynamic Dual **short** leg support lengths suits persons with lower leg length from around 350 mm up to approximately 450 mm (measured when knees are 90° flexed, from underneath the thigh to under the heel – inclusive normal shoes).

Netti Dynamic Dual **normal** leg support lengths suits persons with lower leg length 450 – 550 mm lower legs.

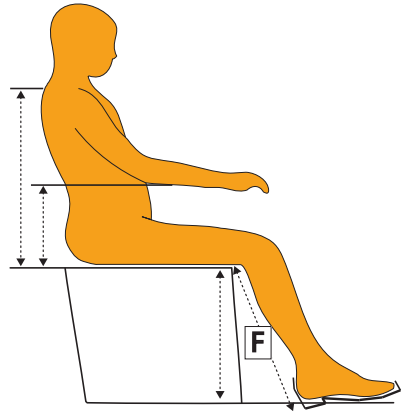

DUAL LEG SUPPORT HEIGHT AND LENGTH ADJUSTMENTS:

Leg support adjustment takes place in 2 directions. First adjustment is the foot board height and the second adjusting the seat plate depth. The aim is have the leg support knee joint and the user knee joint aligned in the same axis.

Measure the user's lower leg length F – 90 degrees bent knee – measure from underside thigh to the underside heel of normal used shoe.

The centre joint of the leg support is hidden under the knee-joint upholstery. The illustration with removed upholstery shows the leg support knee-joint centre which is to be at the same axis as the knee-joint of the user. Adjust the foot board height according to the lower leg length measured.



**NETTI DYNAMIC DUAL
FOOT-BOARD HEIGHT ADJUSTMENT:**

- Loosen the M6 screws holding the leg support length-profile on the outside with 5 mm Allen-key.
- Adjust the foot-board to a height from top of front edge seat cushion to the foot-board equal to the lower leg length – F dimension.



1 pc 5 mm Allen-key.



Make sure there is enough free space under the foot-board for the wheelchair to pass minor obstacles. Slightly tilting the seating unit may help. If not sufficient, the chair height must be adjusted as described in this user manual chapter 5.4.



**CORRECT SEAT DEPTH:**

Adjust the seat plate and position as described in chapter 5.4.4.

Loosen the Velcro straps of the back support. Let the user sit onto the wheelchair – with cushions mounted. Check that the user is getting into the chair firmly.

Adjust the back support by pulling the straps of the Velcro. The knees of the user should align with the joint of the leg support both in height and in depth.

This will ensure that the user gets a good back support and pressure distribution under the thighs.

Extension pieces allow for adjustments for different leg lengths.

DUAL CALF SUPPORTS HEIGHT AND DEPTH ADJUSTMENTS:

With both leg supports in correct height, the calf supports must be adjusted.

HEIGHT ADJUSTMENT:

Loosen the two M6 screws with 5 mm Allen-key – on the half-moon brackets – holding the calf pad arm. This allows the calf support-pad arm to move up and down. The calf supports should in addition to supporting the calf also help prevent the feet sliding backwards from the foot-board.

Choose a height covering the middle and lower part of the user's calf and tighten the screws.

Twist the calf pads to an angle giving support for the leg when the foot support is angled. The calf pads can swing freely to follow the movements and adjust to the user's leg position.



1 pc 5 mm Allen-key.

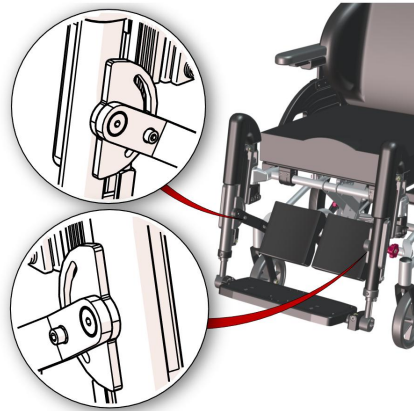

DEPTH ADJUSTMENT:

Loosen the M8 screw holding the calf pad on the calf pad arm with 2 pcs 13 mm spanner and slide the calf pad in or out to desired depth – the calf pad barely touching the calf while the feet are standing on the middle of the foot board.

They should in addition to supporting the calf also help prevent the feet sliding backwards from the foot-board.



2 pcs 13 mm open-end spanner.

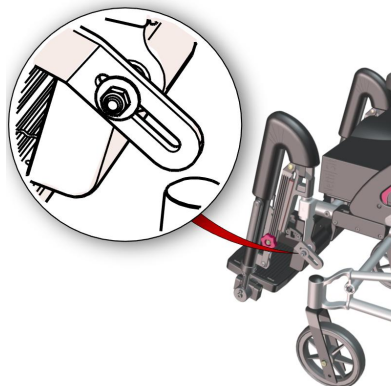

DUAL FOOT-BOARD ANGLE ADJUSTMENT:

Loosen the M8 screw on the left foot board with 6 mm Allen-key. This allows the foot-board to rotate. Choose a foot-board angle to accommodate the user's foot angle. Fix the screws tightly so that the foot-board does not move.



1 pc 6 mm Allen-key.



The Dual foot-board still allow for some rotation forward to flex when the user extends his / her feet.



Lubrication of the gliding length profiles with white Vaseline is important to ensure smooth function of the Netti Dynamic system leg supports Dual.

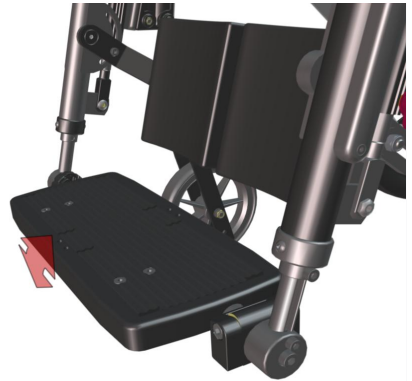
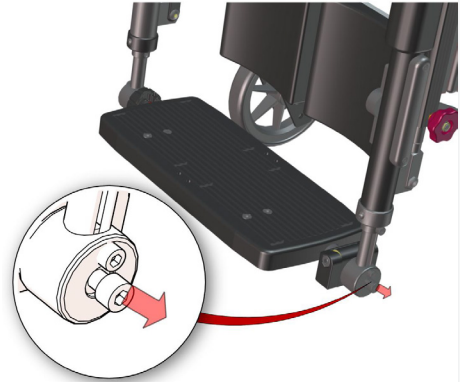

5.10.6 LOCKING THE NETTI DYNAMIC DUAL LEG SUPPORT

The red star knobs allow locking the dynamic elevation of the leg support plate.

For the dynamic use of the Netti Dynamic system (OK-C) this should be kept loose to allow for the knee joint to move (OK-C movement for the knee joint).

Locking the leg support may be required if sudden extension may lead the leg supports to hit persons or surrounding. it is also required if the wheelchair is being used as a seat in a car.



5.10.7 ADJUSTMENTS FOR DIFFERENT LEG LENGTHS

ONE-SIDED FOOT-BOARD DEPTH ADJUSTMENT:

By uneven leg length or leg position: the leg support and foot-board depth can be adjusted to compensate for this by the use of extensions pieces and extension bracket on the right leg support.

The extension piece is pulled forward and fixed in needed length on the side where the leg is longer. The leg support sits in the extension piece and is therefore also moved forward.

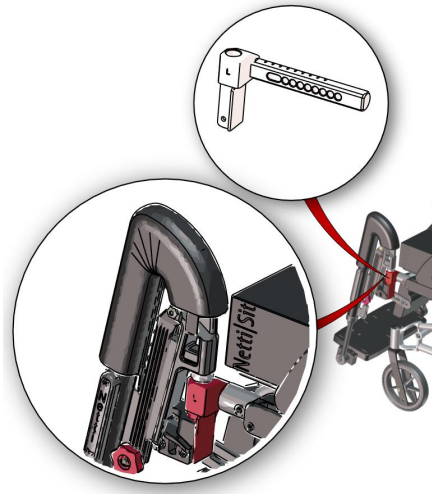

For the foot-board to fall into the foot-board lock after one sided extension piece adjustment, the foot-board has to be repositioned.

The foot-board lock is removed from the length profile where it normally sits – and mounted to the extension bracket.

The extension bracket is mounted to the length profile where the lock was sitting.

Fix the foot-board extension bracket with 2 M6 screws with 5 mm Allen-key through the length profile into 2 nuts.



1 pc 5 mm Allen-key.

Fix the foot-board lock with one M8 screw with 6 mm Allen-key.



1 pc 6 mm Allen-key.

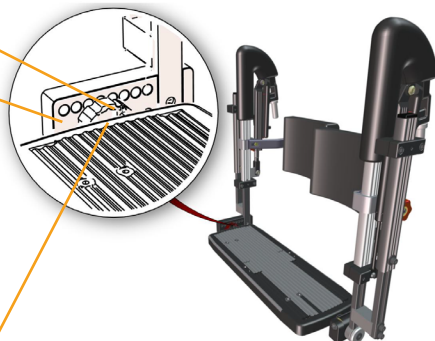

This picture shows the bracket reaching forward, allowing for longer left leg where the right leg support and calf pad has to go backwards:
 – suiting a user with shorter right leg.

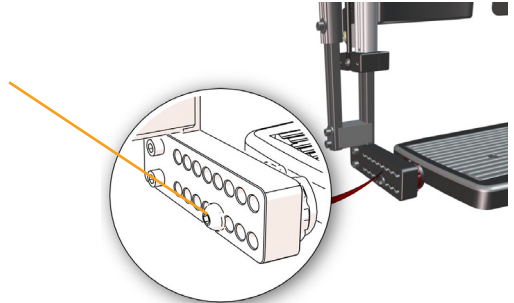

This picture shows the bracket reaching backwards, allowing for longer right leg where the right leg support and its calf pad go forwards:
 – suiting a user with longer right leg.

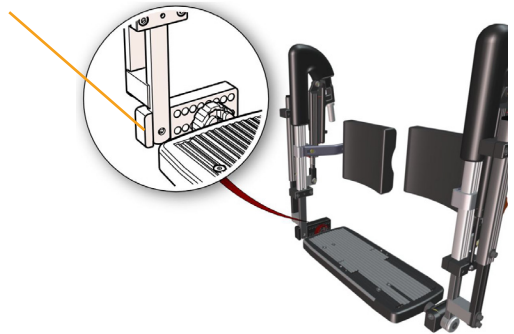

All mounting illustrations are showed for Netti Dynamic Parallel.
 The mounting procedure for Netti Dynamic Dual is similar.

Extension platform kit for Dual leg support:
 82940 and 82941.

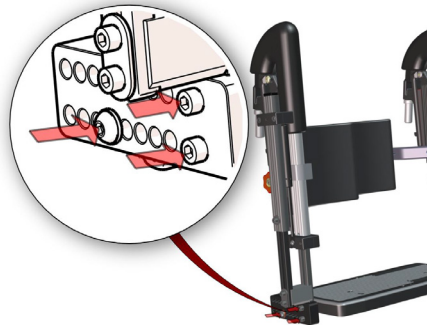

5.10.8 LEG SUPPORT MOUNTING AND REMOVAL

Mount the leg supports to the wheelchair. Ensure an open angle of the leg support when inserting:

Position the bolt vertical into the frame hole turning it around 30 degrees outward for it to enter easy. Turn it inward until it clicks into user position.

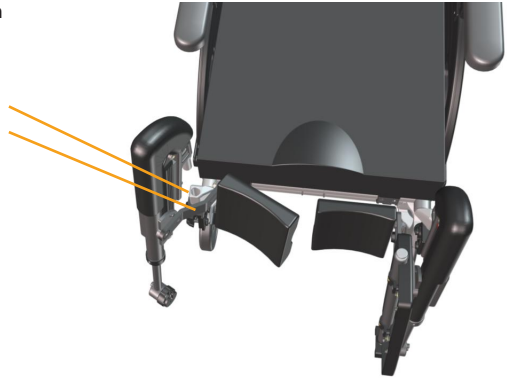

5.10.9 FOOT PLATE LOCK

Leg supports can have foot-plates replaced by a foot-board. With both leg supports in place, the foot-board folds down into the lock on the right leg support.

The lock is closed by turning the outer ring 90 degrees forward!

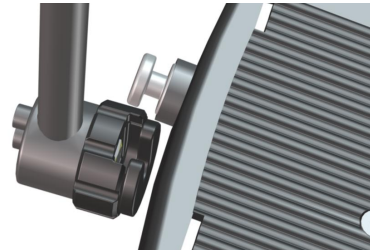

 The foot-board lock **MUST** always be closed when the chair is occupied.

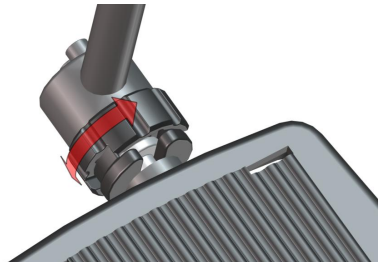

5.11 SIDE SUPPORTS

Netti *AdaptPro* is prepared for fixing side support to the back tubes.

- Fold the chair-back forwards by releasing the pin.
- Insert square nuts into the back tube. At the top of the tube there is a wider space where the square nuts can fit into the groove.
- Fix the side support bracket to the back tube by screwing it to the square nuts you just inserted.
- Rise the back and adjust side support position suitable for the user.
- Adjust height, depth and inward position.



5 mm Allen-key.

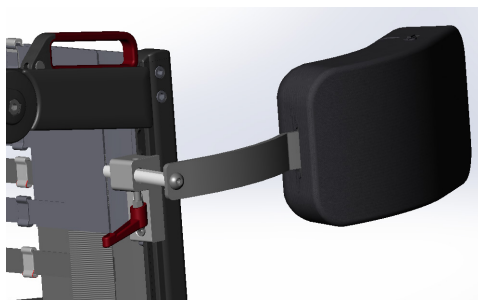
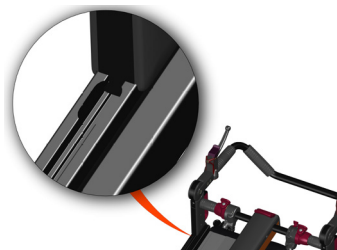

5.12 ABDUCTION BLOCK

Netti *AdaptPro* seat plate is prepared for mounting abduction block to the front of it.

- Screw the abduction block to the seat plate in the nuts prepared for this.
- Position it in the centre of the plate.



3 mm Allen-key.

- Adjust the height to fit the block tightly over the seat cushion.



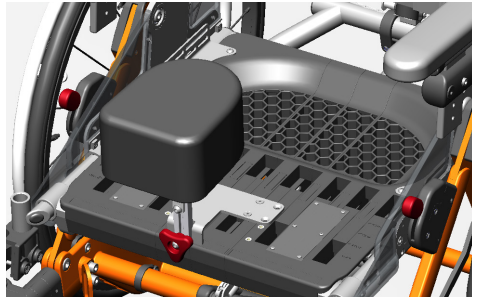

4 mm Allen-key.



5.13 THIGH SUPPORT

Netti *AdaptPro* seat plate is prepared for mounting thigh support to the top of it. They are fixed similar as the abduction block.

5.14 TABLE

-  **Netti *AdaptPro* can be fitted with a table. Since the arm supports follow the back movement, it is require to lock the chair in a position with horizontal arm supports when the table is used.**
-  **Please do a user assessment to determine if a table is suitable.**



-  **Never place any items on the table that may cause harm or can brake when the arm supports are not horizontal.**

6. EVERYDAY USE OF NETTI *AdaptPro*



A Netti *AdaptPro* wheelchair is an advanced mobility aid. Please use some time to study this manual and become familiar with the wheelchair and all its possibilities.

Max. user weight for Netti *AdaptPro* is **160 kg**.

After the wheelchair has been correctly adjusted to the user described in the previous chapters, you as an attendant need to learn how take advance of the tilt and recline features to give the user the most benefits of the chair.

SEAT UNIT ANGLE – TILT

The seat unit angle is regulated with the tilt handle on the push bar left. The seat unit can be tilted from -3° to $+30^{\circ}$.

-  **To prevent unintentionally tilting the seat unit from vertical to 3 degree forwards requires more force.**
-  **The tilt function is used for giving variation of the seating position for the user.**

BACKREST ANGLE – RECLINE

The backrest angle is regulated with the recline handle on the push bow, right. The recline angle can be regulated from 86° – 133° . A scale on the back cylinder lower tube, show which recline angle is used.

-  **The recline angle to be adjusted by the therapist to accommodated to the user's best seating position. Always returned to this angle when sitting in upright seating position.**



6.1 KEY WORDS REGARDING TILT AND RECLINE OF COMFORT WHEELCHAIRS

Tilt and recline are the basic benefits of a comfort wheelchair. It allows for varying seating positions during the time in the wheelchair, for creating correct position, maintaining stability, stimulate ADL and protecting skin.

We have reviewed the clinical evidences regarding tilt and recline, and found there are several studies and best practice guidelines suggesting that the tilt and recline sequence is important to reduce shear and sliding:

When changing to a resting backwards leaning position: tilt first, then eventual recline.

When bringing the user upright from a resting position, the sequence should be reverse; first correct the recline angle then the tilt.

The most shear is induced when going upright from a recline and tilted position.

6.2 DECREASE THE POSSIBILITY OF SLIDING, SHEAR AND PRESSURE SORES

By upright normal seating the muscle tone of the neck and back should be as low as possible for the user to prevent sliding. The therapist will identify the correct recline angle. A change of the recline angle from this position can disturb the correct body position, and cause an increased muscle tone in the neck.



If the recline function is used during a transfer situation or other situations, it is very important that the recline angle is adjusted back to the correct, original position when the user is back to a normal seating position.



Wrong use of recline can cause loss of position, an increased risk of sliding, an increased danger of shear strain and pressure sores.

6.3 OPERATING RECLINE: RECLINING THE CHAIR BACK

Operate the recline handle on the right side of the push bow and recline the chair back. It will stop where you let loose.

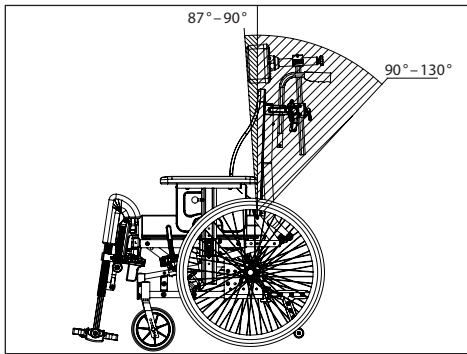

MAKE SURE THAT THE USER IS SAFE WHEN TILT OR RECLINE ARE GOING TO BE ADJUSTED:

The tilt and recline functions of all Netti wheelchair models are «one hand operations». This is a benefit for the user: The care giver is able to establish eye contact and communicate with the user when the tilt or recline function is going to be used. The user can feel more safe when tilted or reclined while eye contact is maintained between attendant and user.

6.4 OPERATING TILT: TILTING THE SEATING UNIT

Operate the tilt handle on the left side of the push bar and move the seating unit to desired position. The relative angle between the body upper and lower parts remain the same when the seating unit is tilted. A tilt scale on the side of the chair shows which tilt angle has been chosen. Netti *AdaptPro* can be forward tilted -3° and backwards tilted $+30^\circ$. A backward tilted seat unit can create position, an decreased risk of sliding, an decreased danger of shear strain and pressure sores.

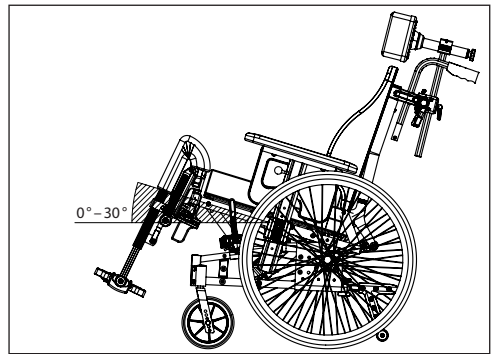

A forward tilted seat unit brings the user in a position where activities, for instance by a table or by standing up from the wheelchair, are supported.

 **Never leave the user alone when the seat is tilted forwards. The user may slide forwards out of the chair.**

6.5 PRACTICE THE USE OF THE NETTI *AdaptPro* TILT AND RECLINE SYSTEM TOGETHER WITH THE USER

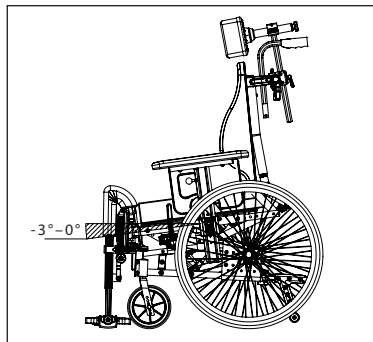

- Practice using the tilt function leaning the complete seating unit backwards and forward, experiencing and testing how the user react. Tilt is recommended to be used for varying seating positions, leaning backwards for resting – see page 91 for details.
- Practice using the recline function by changing the back angle only. This is helpful when using a hoist to transfer the user in and out of the chair. Please return to correct recline angle after transfer.

i Make sure the belts and harnesses are fixed in the best way for the user.

i A hip belt is often of benefit for the user – to keep the seating position and for the safety.

Upper body harnesses can be useful to connect the user to the back support. When using upper body harnesses the hip belt must always be locked first.

i Ankle huggers can be beneficial by connecting the feet to the foot plate helping preventing them from sliding of.



6.6 TRANSFER TO AND FROM THE WHEELCHAIR

Techniques for transferring to / from the wheelchair should be practiced well with the persons involved.

Some important advices for preparation of the chair:

- The wheelchair should be placed as close as possible to the destination of the transfer.
- Make sure the brakes of the wheelchair are activated to prevent it rolling away.
- Remove the leg support.
- Swing away the arm support on the side of the transfer.
- Eventually remove the head support.

6.7 USING A PATIENT HOIST

- Make sure the brakes of the wheelchair are activated to prevent it rolling away.
- Tilt the chair slightly backwards.
- Remove the leg support.
- Open the back support angle slightly while holding the user and adjusting the hoist behind the users back.
- Option: Swing away the arm supports to get closer to the patient and / or remove the head support.
- Replace the components when the transfer is finished.



6.8 DAILY ATTENDANT HANDLING

6.8.1 PUSH BOW

The push bow is easily swung up to or down at any time enabling good control over the wheelchair in the varying positions.

For safe manoeuvring the wheelchair, and preventing injuries for the attendant, the push bow should be adjusted according to attendants arm height when the elbow is in an **90** degree angle.

Open the **2** handles holding the push bow and swing it to desired height before fixing them by pushing them down.

The push bow can be swung up or down at any timer, reducing the length of the wheelchair.

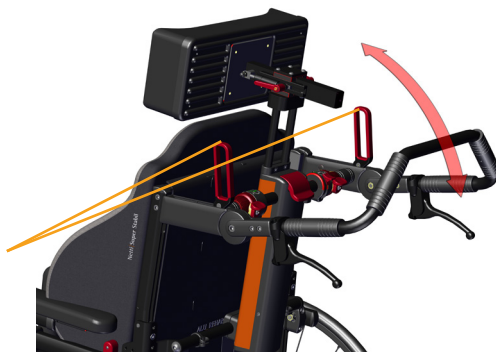

Please note: If the push bow start to slide downwards during use, the 2 handles holding the push bow must be tightened. See instruction on pg 54.

6.8.2 ANTI-TIPS

Netti *AdaptPro* have anti-tips to ensure a safe and stable wheelchair at any time. They are pre-mounted and follow the position of the main wheels ensuring that the anti-tip function is active at any time.

The anti-tips have a tramping pedal to be used for tipping the wheelchair backwards when passing obstacles.

- Step with one foot on the tramping pedal.
- Push the push bow downwards and at the same time.
- Tip the wheelchair.

 **Please note: When the seat unit is tilted backwards, the drive wheels are moved backwards, and the front wheels will be lifted higher than with not tilted seating unit.**



6.8.3 BRAKES

Netti *AdaptPro* is equipped with drum brakes that can be operated both with the brake handles on the push bar and from the parking / user brake in front of the main wheels.

The brake handles on the push bow can be used as running brakes like on a bicycle.

USER BRAKE = PARKING BRAKE

Push the red brake handle forward to lock the brake one on each side of the chair.



Always use the parking brake when the wheelchair is left without attendant standing close. Lock the parking brakes on both sides.



6.8.4 ARM SUPPORTS

Netti *AdaptPro* is equipped with swing away arm supports.

LOCKING – UNLOCKING

The arm supports are locked in a horizontal position to make sure the arm support does not unintentionally swing away.

To unlock the arm support lock:

Push the small red handle close to the elbow – rear end of the arm support pad – backwards and swing the arm support up.

When the user is to leave the chair, the arm support can be swung away. This makes the transfer much easier.

Please, see the illustration of a chair with swing away arm support.



6.8.5 HEAD SUPPORT – MOUNTING

Netti *AdaptPro* can be equipped with Netti Dynamic head support.

The dynamic head support follows the backwards movement of the neck. This is beneficial both for users with involuntary movements and users nodding or banging the head.

The depth of the head support should be adjusted to barely touch the back of the user's head when sitting relaxed.

Head support depth adjustment should be set by the therapist adjusting the wheelchair to the user.

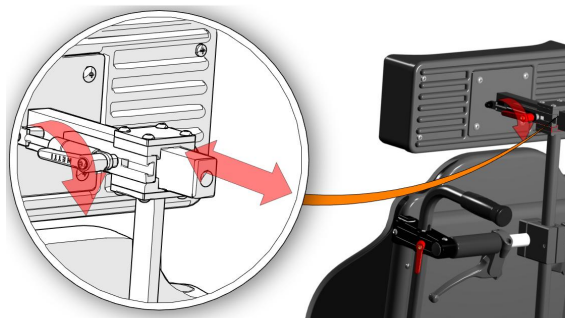

HEAD SUPPORT MOUNTING AND REMOVAL:

The head supports for Netti *AdaptPro* are easily mounted and removed:

Open the latch on top of the back cylinder house. The head support is released and can be removed.

When the latch is open you mount the head support by inserting the 2 head support rods into the top of the back cylinder house and close the latch.

The height of the head support needs to be adjusted to fit directly behind the head giving support to the lower part of the skull.



6.8.6 LEG SUPPORTS – MOUNTING

NETTI LEG SUPPORTS ARE MOUNTED LIKE THIS:

Push the leg support fixing bolt vertical into the leg support fixing bracket on the wheelchair – keeping the leg support slightly turned outwards.

The leg support will fall in place and turn into place itself.

TO REMOVE THEM:

Unlock the foot plate. Pull the leg support slightly upward and swing it outwards before lifting and detaching it from the chair.



6.8.7 LEG SUPPORT FOOT BOARD

Netti Dynamic DUAL leg supports are equipped with a foot board. It is linked to the left leg support and folds down into a foot board lock in the right leg support.



FOOT BOARD LOCK:

With both leg supports in place, let the foot board swing down and put the bolt into the lock, see pictures to the right.

Rotate the outer ring to lock it.



 Always lock the foot board when the user sits in the chair. Failing to lock may lead to damage to the leg supports and eventual also harm to the user.

6.8.8 LOCKING DYNAMIC LEG SUPPORTS

The Netti Dynamic Dual Leg support angle can be locked by tightening the red wheel on the outside of the leg supports.

See illustration:

This stops dynamic movements except for the limited rotation of the foot-board.

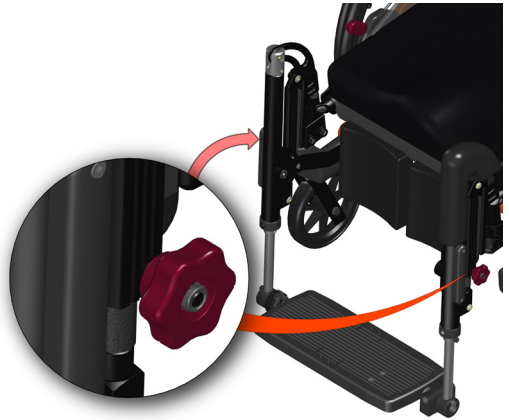

Always lock the dynamic function of the leg supports when the chair is used as a seat in a car.

6.9 BELTS AND HARNESES

Use harnesses, pelvic stabilizers and ankle huggers / shoe shells to give the user needed stabilizing support.



Always use the mounted belts, harnesses and ankle huggers to secure the user when sitting in the *Netti AdaptPro*.

Netti AdaptPro is prepared for mounting several different types of pelvic stabilizer and supportive harnesses, each type developed to give the user the best stabilization support depending on the conditions:

- Pelvic stabilizer
- Upper body harnesses
- Ankle huggers
- Shoe shells.

PELVIC STABILIZER,

mounted to the seat plate, helps the user to keep his position on the seat even under restlessness and involuntary movement.



Max. backwards tilt, max. recline

HOW TO ADJUST THE PELVIC STABILIZER:

The pelvic stabilizer is mounted on the belt fixing brackets on the seating plate.

- Slide the pelvic stabilizer to a position where it crosses the upper thighs and angle 70–90 degrees.
- Adjust the length of the pelvic stabilizer / belt and mounting point so that the belt can be tightened.

i **A pelvic stabilization belt must always be used when using upper body harness and always be locked before locking the harness.**

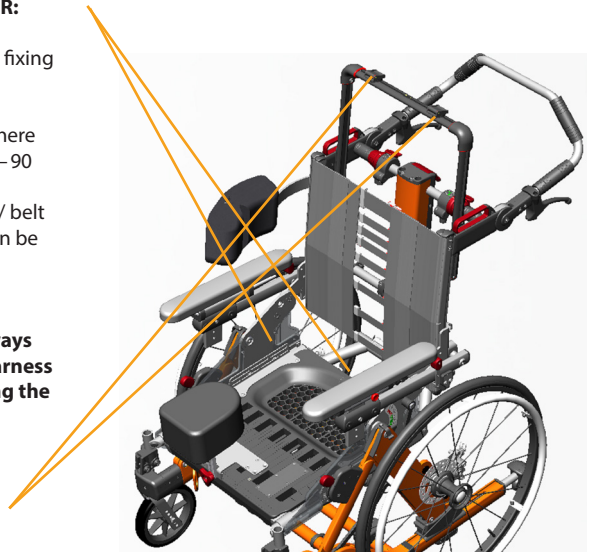

THE UPPER HARNESES

are mounted with Quick-Locks to the harness rail behind the back support. The Quick locks are easy to open and adjust at any time.

ANKLE HUGGERS AND SHOE SHELLS

are mounted to the foot board. They help to keep the feet on the foot board not letting them slide off the foot plates or foot board.

7. TRANSPORT

7.1 TRANSPORT IN CAR

Whenever possible, transfer to a car seat with vehicle safety belts when you are travelling with a car. Secure the wheelchair or store it in the cargo area of the car.

Netti *AdaptPro* is tested and approved by crash test ISO 7176-19 stating it is suitable to be used as a seat in a vehicle.

Before using the **Netti *AdaptPro*** as a seat in a car, be sure to remove and secure all auxiliary parts and accessories (eg. trays) that may fall off the chair in case of an accident and secure them safely elsewhere.

 **Always use approved wheelchair and occupant restraint system (ISO 10452) for fixing the wheelchair in the vehicle.**



The chair is marked with stickers showing where to fix the straps. 4 car fixing loops are part of the frame.



In front:
Use hook or strap attachment.



In the rear:
Hook on a hook / carbine hook into the car fixing loops on the frame.
The angle of the straps should be close to 45°.

- i** **Raise the chair to an upright seat position with max 10 degree tilt and 10 degree recline. Swing the push bow up and fix it behind the head support.**
- i** **Netti *AdaptPro* seat width 350 – 500 mm is approved for user weight up to 135 kg when used as a seat in a vehicle.**

i **REMOVE ACCESSORIES**
Netti *AdaptPro* has been crash tested without any power assistant device etc. If, at a later point of time a power kit, stair climber etc. is mounted, you need to check if your power assistant device is crash tested and approved for wheelchairs being used as seat in a car. If not, the assistant device must be dismantled and secured elsewhere, when the wheelchair is used as a seat in a car.

x **The corrective harnesses used in the wheelchair are not safety belts.**

- i** **SECURING THE USER**
Always use 3-point car occupant restraint belts.

Make sure the car safety pelvic-belt lay tightly across or in front of the pelvis – the angle between pelvic belt and the horizontal between 30 – 75 degree, the steeper angle the better. The shoulder belt must lay close to the body of the user. See illustration.

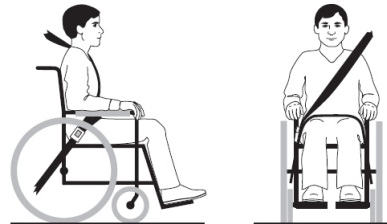

x **The shoulder belt must not lay across arm supports, wheels etc. See illustration**

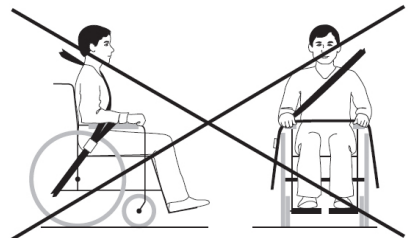

Netti AdaptPro has been successfully crash tested in a forward facing orientation with both pelvic and shoulder belts, according to the requirements of ISO 7176-19 using a combined wheelchair and occupant restraint system W120/DISR from Unwin Safety Systems.

For further information:
BraunAbility Europe.
<https://www.braunability.eu/wtors>

The rating for the wheelchair's accommodation of vehicle anchored belt restraints is rated **A = good**.

 Always use both pelvic and shoulder restraints to reduce the possibility of head and chest impact with vehicle components.

 Never use the wheelchair as a seat in a car if it has been involved in an accident with impact, before the chair has been inspected and approved for this by the manufacturer's representative.

Watch out that the belt is not twisted and the release buckle will not get in contact with the chair in case of a crash.

 If the user is 1.85 m or longer, the back extension kit must be mounted when **Netti AdaptPro** is used as a seat in a car.

 If a **Netti** head support is mounted correctly it is very stable but does not replace the need for an external neck support mounted in the car.

 Always use **Netti Cushions** when **Netti AdaptPro** wheelchair is used as a seat in a car.

 **Netti AdaptPro** with seat width 500 mm and more, exceed the max width of 700 mm specified in PRM-TSI and have influence on the possibility for train transport.

 Alterations or substitutions should not be made to the wheelchair securements points or to structural and frame parts or components without consulting the wheelchair manufacturer.

7.2 FOLDING FOR TRANSPORT

When the wheelchair is unoccupied, fold it as described below. Put the wheelchair in the trunk or the back seat. When placed in the back seat, secure the frame using safety belts.

- Remove head support (chap. 6.9.5)
- Swing push-bow up (chap. 6.9.1)
- Revolve the arm supports up (chap. 6.9.4)
- Remove leg supports (chap. 6.9.6)
- Remove backrest cushion
- Release backrest and fold it forwards (chap. 5.5)
- Remove main wheel (chap. 5.3)
- Remove front castor (chap. 5.3.3).

7.3 TRANSPORT IN AIR-PLANE

Netti *AdaptPro* wheelchair may be transported in air-plane without any restrictions. Netti *AdaptPro* wheelchairs are equipped with 3 gas cylinders. These are however not classified as dangerous goods. Netti *AdaptPro* is configured with tilt and recline functions which are activated with gas spring(s).

Contrary to general dangerous goods instruction UN3164, the IATA-DGR (special regulation A114) rules that the goods that contain gas and are determined to function as shock absorbers (including energy-absorbing devices or pneumatic springs) are NOT subject to the transport instructions i.e. they are indemnified from the following requirements:

- a) Each article has a gas volume which does not exceed 1,6l and a charge pressure not exceeding 250 bar, where the product of the capacity expressed in litres and charge pressure expressed in bars does not exceed 80.
- b) Each article has a minimum burst pressure of 4 times the charge pressure at + 20 degree Celsius for products not exceeding 0,5l gas space capacity.
- c) Each article is made of material that will not fragment.
- d) Each article was manufactured in accordance to quality standard which is approved by the responsible national authority.
- e) It is proven and shown that the article relieves its pressure by means of a fire degradable seal or other pressure relief device such that the article will not fragment and the article does not rocket.

7.4 TRAVELLING ON PUBLIC TRANSPORT

The wheelchair should be put in a special area for wheelchairs.

The wheelchair should face opposite the direction of travel. The back of the wheelchair must be located against a fixed object such as a row of seats or a partition. Make sure the user can easily reach any hand rails or handles.

Use belts and harnesses in the chair to hold the user. Use safety belts if available to secure the user in the vehicle.

8. MANOEUVRING

8.1 GENERAL TECHNIQUES

SITTING IN YOUR CHAIR

Once on your chair, make sure that you are comfortably positioned and that the leg supports and arm supports have been adjusted to suit your needs and that you have good back support.

GUIDELINES FOR USE

 Always drive carefully. Make sure your seating position is not tilted and reclined in a way that you do not have the overview when driving.

 **BALANCE**

The weight load and balance of the chair influences the manoeuvring ability of the wheelchair. The weight, size and sitting position of the user are also influencing factors.

The size and position of the wheels will influence the driving performance. The more weight placed over the main wheels, the easier it is to manoeuvre. If heavy weight is placed over the front castors, the chair will be heavy to manoeuvre.

To increase backward stability a frame extender bracket can be mounted.

 Avoid carrying bags on the push handles, it may make the chair unstable.

 The large available tilt and recline positions of the chair influences the manoeuvrability of the wheelchair. When large tilted / reclined position is used, the chair is not meant to be driven long distances. By swinging the push bow up, the attendant can drive the wheelchair with large tilted / reclined position for shorter distances like transferring from room to room.

**RIGIDITY**

The large available tilt and recline movements have influence on the rigidity of the wheelchair. An additional crossbeam between right and left chair frame can be ordered and mounted for increased sideways stability. The choice of main wheels also influences the rigidity. 16" wheels are more rigid than 24" wheels.

**PASSING OBSTACLES**

The anti-tippers following the rear wheel position, may get in conflict with steps and obstacles when passing. Be very careful when you have to pass even small heights.

**STEP APPROACH**

Always approach a step in slow motion preventing the front castors to hit the step with force. The user could fall out of the chair by the impact. The front castors could brake.

**DRIVING FORWARD DOWN STEPS / SIDEWALKS**

Be cautious that you do not drive down steps higher than 30 mm. The leg supports may hit the ground first. Thereby you might lose the control and the leg supports may brake.

**PARKING**

Increase the underneath support of the wheelchair by moving the chair about 100 mm backwards making the front castors turn forward.

**DRIVING ON SOFT, ROUGH OR SLIPPERY GROUND**

can make safe manoeuvring more difficult as the wheels may lose traction and it is difficult to control the wheelchair.

 **LEAVING THE USER UNATTENDED:**
If the user is left alone in the wheelchair, always lock the brakes and secure that the anti-tips are turned down.

 **EMERGENCY ESCAPE ROUTES:**
Netti *AdaptPro* with seat width 500 mm and more, has an overall width exceeding 700 mm and may have difficulties passing emergency escape routes.

Please be aware that wider wheelchairs have bigger turning radius and reduced manoeuvrability in vehicles. Smaller wheelchairs generally provide greater ease of vehicle access and manoeuvrability to a reach forward facing position.

8.2 DRIVING TECHNIQUES – STEP UP –



The anti-tippers following the rear wheel position, may get in conflict with steps and obstacles when passing. Be very careful when you have to pass even small heights.

Companions, drive up a step forwards:

- Fold the push-bow down.
- Angle the wheelchair backwards on the drive wheels by stepping on the anti-tipper-pad before pushing on the push-handles.
- Push forward till the front castors stand on the step and continue to push while you also lift holding on to the push-handles.

Users, drive up a step backwards:

This technique is only useful if the step is very low. It also depends on the clearance between the foot plates and the ground.

- Drive the chair backwards towards the step.
- Make a firm grip on the push rims and move the body forward while pulling.

Companions, drive up a step backwards:

- Fold the push-bow down.
- Pull the chair backwards next to the step.
- Angle the wheelchair backwards, moving the front castors slightly up in the air.
- Pull the wheelchair up by the push handles onto the step and go backwards long enough to put down the front castors on the step.



8.3 DRIVING TECHNIQUES – STEP DOWN –

i The anti-tippers following the rear wheel position, may get in conflict with steps and obstacles when passing. Be very careful when you have to pass even small heights.

Companions, drive down a step forwards:

- Fold the push-bow down.
- Angle the wheelchair backwards, moving the front castors slightly up in the air.
- Drive carefully down the step and angle the wheelchair forward putting the front castors back on the ground.

Companions, drive down a step backwards:

- Move the wheelchair backwards to the step.
- Drive carefully down the step and move the wheelchair backwards on the main wheel until the front castors have come away from the step.
- Put the front castors down on the ground.

8.4 DRIVING TECHNIQUES – SLOPE –

Important advice for driving down and up hill avoiding the risk of tipping.

i Avoid turning the wheelchair in the middle of a slope.

i Always drive as straight as possible.

i It is better to ask for assistance than taking risks.

Driving uphill:

Move the upper part of the body forwards in order to maintain the balance of the chair.

Driving downhill:

Move the upper part of the body backwards to maintain balance of the chair.

Control the speed of the chair by clutching the push rims. Do not use the brakes.



8.5 DRIVING TECHNIQUES – UP AND DOWN STAIRS –

i Due to the weight load – with wheelchair and user, we do not recommend driving a Netti *AdaptPro* wheelchair up or down stairs.

The strain on assistants will be more than the manual handling regulation and the ergonomic assessment max load.

The risk for losing control during stair passing can lead to danger for both wheelchair user and assistants.

i Use ramps and elevators when moving the user to higher or lower floor.

i Never use escalators, even if assisted by a companion.

⚠ Do not lift the wheelchair holding onto the push-bow, leg, arm or head supports.

8.6 TRANSFER

Techniques for transferring to / from the wheelchair should be practiced well with the persons involved. Here, we give some important advices for preparation of the chair:



With or without companion – sideways.

Before transfer:

- The wheelchair should be placed as close as possible to the destination of the transfer.
- Pull the wheelchair backwards 50 – 100 mm in order to make the front castors turn forward.
- Lock the brakes.
- Remove leg support and swing up the arm support on the side of the transfer.

With or without companion – forwards.

Before transfer:

- The wheelchair should be placed as close as possible to the destination of the transfer.
- Pull the wheelchair backwards 50 – 100 mm in order to make the front castors turn forward.
- Lock the brakes.
- Tilt chair forward.

Using a lift / hoist:**Before transfer to chair:**

- Tilt the chair slightly backwards.
- Remove the head support.
- Remove the leg supports.
- Open the backrest angle slightly.
- Replace the components when transfer is finished.



Never stand on the foot plates due to the risk of tipping the chair forwards.

8.7 POINT OF BALANCE

Adjust the point of balance by adjusting to correct seat depth for the user. This will move his / hers centre of gravity and balance the wheelchair. In addition one can consider to change the position of the main wheel in the main wheel bracket.

- Move the main wheel hub and the main wheel. (Chap. 5.3.1)
- Adjust the drum brakes. (Chap. 5.3.6)
- Check that the main wheel and quick-release are locked properly. (Chap 5.3)



2 pcs 24 mm open-end spanner.



5 mm Allen-key.

The Netti *AdaptPro* main wheel bracket allows for changing wheel position and thereby changing the seat height. If required frame extenders bracket can be mounted to move the main wheel 60 mm backwards.

For users with forceful involuntary movements it is possible to mount counterweights on the wheel-frame front.



The point of balance can also be changed by adjusting the seat angle and / or angle of backrest.

8.8 LIFTING THE WHEELCHAIR

The unfolded wheelchair without user should be lifted from 2 persons holding on to the frame and push bar only. It is marked with a symbol where it should be lifted.

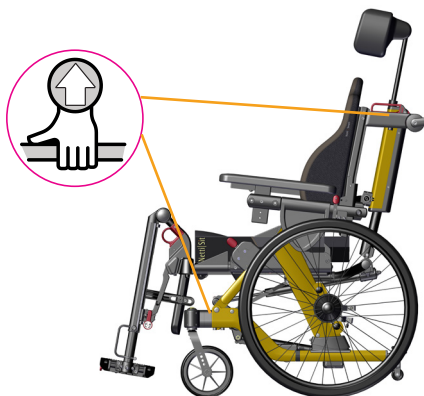



Never lift the wheelchair when holding on to the leg, arm or head supports. They may detach and the wheelchair may fall and get damaged.

8.9 PUSH RIM

Netti wheelchairs are delivered with aluminium push rims as standard. The material and distance to the main wheel influences the ability of the user to grip. Contact your dealer to get information about push rims that fit your chair.

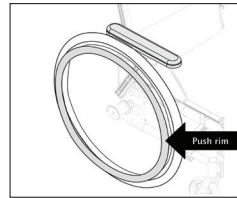
-  Alternative push rims may give better grip, but the friction may increase. When using the hands to stop the chair, the risk for burning of the hands increases.**



-  A squeezing and trapping hazard of the fingers may occur when passing through narrow passages and if the fingers come between the spokes. To avoid this risk, we recommend spoke protectors as accessory.**
-  If you want / need to change push rims or increase / decrease the distance between the push rims and the wheel, please contact your dealer.**

 Never lift the wheelchair with a user in it.

9. MAINTENANCE

9.1 MAINTENANCE INSTRUCTIONS



You as a user of the wheelchair (and your attendants and family) are responsible for the everyday maintenance of the chair. Clean it regularly. Do the maintenance to assure safe and long time reliable functions and hygienic appearance.

Frequency	Weekly	Monthly
Check defects / damages e.g. breakage / missing parts	X	
Washing of wheelchair		X
Washing of cushions		X
Check anti-tip function		X
Check brake adjustment		X
Check tyre wear		X
Oiling of bearings with bicycle oil		x
Grease vertical leg support profiles with white Vaseline	X	

9.2 CLEANING AND WASHING

1. Remove cushions before washing the wheelchair.
2. Clean the frame using water and a rag.
3. We recommend using soft soap.
4. Rinse the wheelchair well using clean water to remove all the soap.
5. Use methylated spirit to remove any dirt left.
6. Clean cushions and covers according to instructions printed on cushions.

NETTI CUSHION CLEANING PROCEDURES

CORE	
Washing	Hand wash 40 °C
Disinfection	Virkon S
	Auto clave 105 °C
Drying	Squeeze
	Air dry standing edgewise
OUTER COVER	
Washing	Machine wash 60 °C
Drying	Tumble dry max. 85 °C

9.3 LONG TERM STORING

If the wheelchair is to be stored for longer time (longer than 4 months) no special actions are needed. We recommend that the chair is cleaned before storing. Before it being used again, complete the above maintenance instructions.

DISINFECTION OF THE WHEELCHAIR

Remove cushions.

See separate washing instruction above:

Wipe disinfection: use a soft rag wetted with

Hydrogen peroxide or technical alcohol

(isopropanol) and wipe the whole chair clean.

Hydrogen peroxide recommended:

NU-CIDEX "Johnsen and Johnsen".

 **Check / re-adjust screws and nuts at regular intervals.**

 **Sand and sea water (salt used for gritting in the winter) can damage the bearings of the front castors and main wheels. Clean the wheelchair thoroughly after use.**

* As a rule of thumb, use oil on movable parts and all bearings. Alu Rehab recommends use of ordinary bicycle oil.

SPARE PARTS

The Netti chairs are built of modules. Alu Rehab carries stock of all parts and is ready to supply these on short notice. Necessary instructions for mounting will follow the parts.

Parts to be handled by user are defined in spare part catalogues that can be downloaded at **www.My-Netti.com**.

These parts can, if needed, also be removed and sent to manufacturer / distributor upon request.

 **Parts related to wheelchair frame construction must be handled by manufacturer or authorized service facility.**

 **If defects or damages occur, please contact your dealer.**

 **Original paint for repair of scratched, can be ordered from Alu Rehab.**

10. TROUBLESHOOTING

Symptom	Reason / Action	Reference in manual
The wheelchair is going askew	<ul style="list-style-type: none"> The angle of the bearing house might not be 90°. Check that the front castors are fitted in the same height. The main wheel hubs might be incorrectly mounted. One of the brakes might be too tight. The user are sitting very askew in the chair The user might be stronger on one side than the other. 	<p>5.3.2</p> <p>5.3.3</p> <p>5.3.4</p> <p>5.3.5</p>
The wheelchair is heavy to manoeuvre	<ul style="list-style-type: none"> The main wheel hubs might be incorrectly mounted. Clean the front castors and forks for dirt. Too much weight over the front castors (Adjust the point of balance by moving the main wheels back). 	<p>5.3.2</p> <p>5.3.3</p>
The wheelchair is hard to turn	<ul style="list-style-type: none"> Control that the front castors are not fixed too tight. Adjust the angle of the bearing house. Too much weight over the front castors adjust the point of balance. 	<p>5.3.3</p> <p>5.3.4</p>
The front castors are wobbling	<ul style="list-style-type: none"> The front castors are not fixed properly. Check that the front forks are fitted in the same height. The angle of the bearing house might not be 90°. Too much weight over the front castors adjust the point of balance. 	<p>5.3.2</p> <p>5.3.3</p> <p>5.3.4</p>
The main wheels are difficult to take off and put on	<ul style="list-style-type: none"> Clean and grease the quick release. Adjust the length of the hub bushing. 	5.3.6
The brakes are not functioning well	<ul style="list-style-type: none"> Adjust the drum brake. 	5.3.7
The wheelchair feels "shaky"	<ul style="list-style-type: none"> Check screws and adjustment points in general. 	



Please contact your dealer for information about authorized service facilities that can give support if solution is not reached in this form.



When in need of spare parts, please contact your dealer.



When making changes affecting frame construction, contact dealer / manufacturer for confirmation.

11. TESTS & WARRANTY

11.1 TESTS

Netti *AdaptPro* is tested and have been approved for both indoors and outdoors use. The chair is CE marked.

MAXIMUM USER WEIGHT:

135 kg for Netti *AdaptPro* with seat width 350 – 500 mm

It is tested by an accereditated german test laboratory according to EN 12183

Netti *Adaptpro* is crash tested at TASS Netherlands according to ISO 7176-19.

It is approved for being used as a seat in a vehicle.



Maximum user weight when used as chair in a car:

135 kg

Netti seating system is tested for fire resistance according to: EN 1021-2:2014.

11.2 WARRANTY

Alu Rehab is providing you with a 5-year warranty on all frame components and on the cross-tube assembly. There is a 2-year warranty on all other Netti labelled components except batteries. For batteries a 6-month warranty is provided.

 Alu Rehab is not responsible for any damage resulting from inappropriate or unprofessional installation and / or repairs, neglect, wear, from changes in wheelchair assemblies or instructions not approved by Alu Rehab or by use of spare parts delivered or produced by third parties. In such cases, this warranty shall be considered null and void.

 This warranty is only valid when the user use, maintain and handle the wheelchairs as described in this user manual.

11.3 CLAIM

If a product has developed a fault during the warranty period as result of a defect in design or manufacturing, you may forward a warranty claim.

- Claims are to be forwarded as soon as a defect is discovered and not later than 2 weeks after the defect is discovered.
- Claims are to be addressed to the sales agent of the wheelchair. Please note that sales documentation has to be filled in and signed correctly with serial number and eventual NeC number in order to document time and place of the purchase of the wheelchair.
- The sales agent and Alu Rehab are to decide whether a defect is covered by this warranty. The claimer will be informed about the decision as soon as possible.
- If the claim is accepted, the sales agent and Alu Rehab representative are to decide if the product will be repaired, replaced or if the customer is entitled to a reduced price.
- If a warranty claim is judged to be invalid - after careful inspection of the defect (defect due to wrong use and / or lack of required maintenance) you are free to decide if you want to have the product repaired (if possible) at your expense, or if you want to purchase a new product.



Normal wear, incorrect use or incorrect handling is not a reason for claims.

11.4 NETTI CUSTOMIZED / INDIVIDUAL ADAPTATIONS

Netti Customized / individual adaptations are defined as all adjustments that are not included in this manual. Individual adaptations made by Alu Rehab are labelled with a unique NeC number for identification.

Wheelchairs that are especially adjusted / adapted by the customer cannot keep the CE mark given by Alu Rehab A.S Norway. If the adjustments are performed by other than Alu Rehabs approved dealers, the warranty given by Alu Rehab A.S Norway will not be valid.

If you have any uncertainty about special fitting and adaptations, please contact Alu Rehab A.S.



If you have different needs than what our standard wheelchair program can cover, please contact customer service for eventually special adjustments or Netti Customized solutions.

11.5 COMBINATIONS WITH OTHER PRODUCTS

Combinations of Netti and other products not manufactured by Alu Rehab A.S:

Generally in these cases, the CE mark of all the products involved will not be valid.

However, Alu Rehab A.S has made combination agreements with some manufacturers about some combinations. By these combinations the CE mark and warranties are valid.



For further information, please contact your dealer or Alu Rehab A.S Norway directly.

PRODUCT RESPONSIBILITY

Netti *AdaptPro* with different configurations of Netti equipment has been tested / risk evaluated by Alu Rehab.

Any alterations or substitutions must not be made to the wheelchair securement points or to structural and frame parts without consulting the wheelchair manufacturer Alu Rehab.

Substitutions or alterations of components from third part suppliers to Netti *AdaptPro* requires the risk evaluation and acceptance of the product responsibility and safety for use of the wheelchair from the manufacturer that is performing the substitution or alteration.

11.6 SERVICE AND REPAIR

Information about service and repair services in your area, please contact your local dealer.



A unique identification number / serial number is to be found on the crossbar on the wheel frame on left side of the chair.



A spare part catalogue for the wheelchair can be obtained through your local dealer or downloaded at www.My-Netti.com



A refurbishment manual for the wheelchair can be obtained through your local dealer or downloaded at www.My-Netti.com



Information on product safety notices and product recalls are available at www.My-Netti.com



A recycling manual for the wheelchair can be obtained through your local dealer or downloaded at www.My-Netti.com

12. MEASUREMENTS & WEIGHT

Size *	Seat depth Standard **	Back height *** (Extender)	Total width	Weight
350 mm	355 – 455 mm	515 (625) mm	633 mm	48.0 kg
380 mm	355 – 455 mm	515 (625) mm	663 mm	48.6 kg
400 mm	355 – 455 mm	515 (625) mm	683 mm	49.0 kg
430 mm	405 – 505 mm	515 (625) mm	713 mm	49.8 kg
450 mm	405 – 505 mm	515 (625) mm	733 mm	51.0 kg
500 mm	405 – 505 mm	515 (625) mm	730 mm	53.0 kg

- * Dimension between edge of frame tubes.
The distance between cloths protectors: remove 15 mm.
- ** Dimension from front edge of the seat plate to the back hinge – without cushion.
By correct placed UNO back cushion ca. 30 mm must be subtracted from this dimension.
- *** Dimension from seat plate to top of the back.



Weight include main wheels, front castors, leg supports and arm supports. The cushions are not included.



Recommended tyre pressure for pneumatic drive wheel tyres: 40 – 45 PSI.



Max. user weight for Netti *AdaptPro* with seat width up to 500 mm: 135 kg. When used as seat in a car: Max. user weight 135 kg.



When accessories and extra equipment are mounted, the weight of them must be subtracted from the max. user weight.



Luggage loaded on to the wheelchair must not exceed 10 kg. The luggage must not be placed in a manner that reduce the stability of the chair.

Dealer:	
Frame number.:	
Date:	
Stamp:	

Manufacturer of Netti:

📍 Alu Rehab AS
Bedriftsvegen 23
N-4353 Klepp Stasjon
Norway

✉ post.klepp@meyragroup.com
T: +47 51 78 62 20
my-netti.com

EU Distributor:

Alu Rehab ApS
Kløftehøj 8
DK-8680 Ry
Denmark

info@meyragroup.com
T: +45 87 88 73 00
my-netti.com