



Netti® V

# Instruction for use



**CE** This product conforms to regulation MDR (EU)2017/745 for medical products.

IFU0139 UK 2026-06

*inspire  
joy of life*

# CONTENTS

1. INTRODUCTION	5
1.1 AREAS OF USE/INDICATIONS FOR <b>Netti V</b>	6
1.2 CONTRA INDICATIONS	6
1.3 QUALITY AND DURABILITY	6
1.4 THE ENVIRONMENT AND WASTE DISPOSAL	6
1.5 INFORMATION FOR RE-USE	7
1.6 ABOUT THIS MANUAL	7
1.7 VITAL MEASURES	8
2. QUICK REFERENCE	10
3. DESCRIPTION*	11
3.1 INFORMATION ABOUT THE NETTI V SYSTEM	12
4. FEATURES OF <b>NETTI V</b> - Configurations	13
4.1 ACCESSORIES	16
5. ASSEMBLING AND ADJUSTING	19
5.1 UNPACKING	19
5.2 INITIAL ADJUSTMENTS TO THE USER - OVERVIEW	19
5.3 WHEELS ASSEMBLING	20
5.3.1 DRIVE WHEELS	20
5.3.2 CORRECT FRAME ANGLE	21
5.3.3 MAIN WHEEL QUICK RELEASE	21
5.3.4 MAIN WHEEL WIDTH POSITION ADJUSTMENT	21
5.3.5 REPOSITIONING OF THE MAIN WHEELS - OUTWARDS	22
5.3.6 REPOSITIONING OF THE MAIN WHEELS FOR- AND BACKWARDS	23
5.3.7 ANTI-TIPS	24
5.3.8 STEPPER PEDAL ADJUSTMENT	25
5.3.9 FRONT FORK	26
5.3.8 CASTOR POSITION IN FRONT FORK	26
5.3.10 FRONT CASTORS	26
5.3.11 THE BRAKES	27
5.3.12 USER BRAKE ADJUSTMENT	28
5.3.13 DRUM BRAKE ADJUSTMENT	28
5.4 SEAT ASSEMBLING - WHEELCHAIR SEAT HEIGHT	29
5.4.1 SEAT HEIGHT - NETTI V SEAT HEIGHT ADJUSTMENT BRACKET	29
5.4.2 NETTI V SEAT HEIGHT TABLE AND WHEEL POSITIONS	30
5.4.3 NETTI V SEAT PLATE - SEAT DEPTH ADJUSTMENTS	31
5.4.4 BALANCING NETTI V	33
5.4.5 WHEELCHAIR SEAT WIDTH ADJUSTMENTS	34
5.4.6 SEAT WIDTH - ADJUSTING AT THE ARM-SUPPORTS	34
5.4.7 SEAT WIDTH - ADJUSTING AT THE CHAIR-BACK	35
5.4.8 SEAT WIDTH - ADJUSTING AT THE LEG SUPPORT	36

5.5	CHAIR BACK ASSEMBLING AND POSITIONING	37
5.5.1	ADJUSTING THE VELCRO BACK	37
5.5.2	BACK SUPPORT TUBES - SIDEWAYS ANGLES	38
5.5.3	PLACING BACK SUPPORT CUSHION	38
5.5.4	BACK EXTENDER	39
5.6	ASSESSMENT AND CHOICE OF BACK SUPPORT GAS SPRING.	39
5.6.1	CHANGE OF RECLINE GAS SPRING	40
5.6.2	CHANGE OF TILT GAS SPRING	41
5.7	NETTI HEAD SUPPORT ASSEMBLING AND POSITIONING	42
5.7.1	NETTI HEAD SUPPORTS	42
5.7.2	NETTI DYNAMIC HEAD SUPPORT ADJUSTMENTS	42
5.8	ARM SUPPORTS ADJUSTING	43
5.8.1	ARM SUPPORTS HEIGHT -	43
5.8.2	ARM SUPPORTS DEPTH - ARM SUPPORTS POSITION -	43
5.8.3	ARM SUPPORTS HANDLING	44
5.9	BELTS AND HARNESSSES	44
5.10	LEG SUPPORTS	47
5.10.1	LEG SUPPORT HEIGHT AND LENGTH ADJUSTMENTS	47
5.10.2	UNIVERSAL LEG SUPPORTS	48
5.10.3	ANGLE ADJUSTABLE LEG SUPPORTS	49
5.10.4	DYNAMIC LEG SUPPORT HEIGHT AND LENGTH ADJUSTMENTS	52
5.10.5	DYNAMIC CALF SUPPORTS HEIGHT AND DEPTH ADJUSTMENTS	53
5.10.6	DYNAMIC FOOT-BOARD ANGLE ADJUSTMENT	54
5.10.7	LOCKING THE NETTI DYNAMIC LEG SUPPORT	54
5.10.8	GRANDIS LEG SUPPORTS	55
5.10.9	GRANDIS FIXED LEG SUPPORTS	58
5.10.11	LEG SUPPORT MOUNTING AND REMOVAL	59
5.10.12	FOOT PLATE LOCK	59
5.11	SIDE SUPPORTS	60
5.12	ABDUCTION BLOCK	60
5.13	PELVIC SIDE SUPPORT	60
5.14	TABLE	61
<b>6.</b>	<b>EVERYDAY USE OF NETTI V</b>	<b>62</b>
	SEAT UNIT ANGLE - TILT	62
	BACKREST ANGLE - RECLINE	62
6.1	KEY WORDS REGARDING TILT AND RECLINE OF COMFORT WHEELCHAIRS	62
6.2	DECREASE THE POSSIBILITY OF SLIDING: SHEAR AND PRESSURE SORES:	63
6.3	OPERATING RECLINE: RECLINING THE CHAIR BACK	63
6.4	OPERATING TILT:TILTING THE SEATING UNIT	63
6.5	PRACTICE THE USE OF THE NETTI V TILT AND RECLINE SYSTEM TOGETHER WITH THE USER	64
6.6	TRANSFER TO AND FROM THE WHEELCHAIR	65
6.7	USING A PATIENT HOIST:	65

6.8	DAILY ATTENDANT HANDLING	66
6.8.1	PUSH HANDLES	66
6.8.2	ANTI-TIPS	66
6.8.4	BRAKES	66
6.8.5	ARM SUPPORTS	67
6.8.6	HEAD SUPPORT-MOUNTING	68
6.8.7	LEG SUPPORTS - MOUNTING	69
6.8.8	LEG SUPPORT FOOT BOARD	70
6.8.9	LOCKING DYNAMIC LEG SUPPORTS	70
6.9	BELTS AND HARNESSSES	71
<b>7.</b>	<b>TRANSPORT</b>	<b>72</b>
7.1	TRANSPORT IN CAR	72
7.2	FOLDING FOR TRANSPORT	75
7.3	TRANSPORT IN AIR-PLANE	75
7.4	TRAVELLING ON PUBLIC TRANSPORT	75
<b>8.</b>	<b>MANOEUVRING</b>	<b>76</b>
8.1	GENERAL TECHNIQUES	76
8.2	DRIVING TECHNIQUES - STEP UP -	77
8.3	DRIVING TECHNIQUES - STEP DOWN	77
8.4	DRIVING TECHNIQUES - SLOPE	78
8.5	DRIVING TECHNIQUES - UP AND DOWN STAIRS	78
8.6	TRANSFER	79
8.7	POINT OF BALANCE	79
8.8	LIFTING THE WHEELCHAIR	80
8.9	PUSH RIM	80
<b>9.</b>	<b>MAINTENANCE</b>	<b>81</b>
9.1	MAINTENANCE INSTRUCTIONS	81
9.2	CLEANING AND WASHING	81
9.3	LONG TERM STORING	82
<b>10.</b>	<b>TROUBLESHOOTING</b>	<b>83</b>
<b>11.</b>	<b>TESTS &amp; WARRANTY</b>	<b>84</b>
11.1	TESTS	84
11.2	WARRANTY	84
11.3	CLAIM	84
11.4	NETTI CUSTOMIZED / INDIVIDUAL ADAPTATIONS	85
11.5	COMBINATIONS WITH OTHER PRODUCTS	85
11.6	SERVICE AND REPAIR	85
<b>12.</b>	<b>MEASUREMENTS &amp; WEIGHT</b>	<b>86</b>
<b>Appendix</b>		
	Netti V wheel position - front castors and anti-tips	87
	Netti V Screw torques	89

# 1. INTRODUCTION





**Netti V** is a tilt and recline wheelchair with seating system for adolescent and grown up users meant for mainly indoor and some outdoor use. It is tested to EN 12183. The tests were carried out by a German accredited test laboratory.

In Alu Rehab we believe that wheelchairs should be chosen based on a thorough assessment focusing on the needs of the user and demands from environment. It is vital to be aware of the possibilities and limits the wheelchair offers.

**Netti V** is a wheelchair designed for users with great need of comfort and adjustments. It has an adjustable seat and back angle, thus facilitating for the user change of position, mobilisation or posture correction (stabilization).

**Netti V** has been crash tested at TASS International test centre in Helmond Netherlands, according to ISO 7176-19.

-  Max user weight is 135 kg, also when used as a seat in a car.
-  When mounting accessories such as power kit etc, the weight of the accessories must be subtracted from the max user weight.
-  Specifications varies between countries.



## 1.1 AREAS OF USE/INDICATIONS FOR Netti V

**Netti V** is a multifunctional, tilt and recline comfort wheelchair for wheeled transport for partially or fully immobile adolescent and grown up persons with physical and/or mental disabilities.

**Netti V** has a modular system that can be customized and adjusted according to the user's need.

It provides a means by which a disabled person who requires the possibility to vary the sitting position from activity to rest will profit from using tilt and recline functions. It is designed for users with the need for comfort and relief. The combination between the seating system and the ergonomic solution in the frame construction offers many possibilities for adaptation and adjustments.

### IMPORTANT BENEFITS of Netti V

The disabilities may have multiple causes. **Netti V** has an adjustable seat and back angle, thus facilitating for the user change of position, mobilization or posture correction (stabilization), wherever the following functional impediments with their multiple possible causes are present:

- limited or lacking mobility
- limited or lacking muscle power
- limited movement range
- lacking or limited trunk and body stability
- hemiplegia
- rheumatic-type disorders
- craniocerebral injuries
- amputations
- other neurological or geriatric disorders.



Before using Netti V, a seating assessment should be carried out by a trained professional.



If our standard solutions does not cover you needs, please contact our customer service for Netti customized solutions.

## 1.2 CONTRA INDICATIONS

**Netti V** should not be used if:

- the user has strong involuntary movements. It is recommended the use of Netti Dynamic System for these users.

## 1.3 QUALITY AND DURABILITY

**The Netti V wheelchair is tested at a German accredited test laboratory according to the European Standard EN 12183**



As manufacturer, Alu Rehab A.S evaluates the test to be equal to 5-6 years of normal use of the chair.

The disability of the user, the toughness of use as well as the level of maintainance done, foremost decides the durability of the wheelchair. Thus, the durability will vary depending on these three factors. With adequate maintenance, the lifetime of the wheelchair can be expected to exceed the 5 year warranty period by many years.

## 1.4 THE ENVIRONMENT AND WASTE DISPOSAL

Alu Rehab and its suppliers wish to protect the environment.

This means:

- That we avoid using environmentally harmful substances and processes to the greatest extent possible.
  - That Alu Rehab's products are ensured a long service life and a high degree of flexibility - to benefit the environment and economy.
  - That all packaging can be recycled.
  - That the wheelchair was designed to be separated into its component materials - to make recycling easier.
- 
-  Contact your local recycling agent to get correct information how to handle in your area.



### TEMPERATURE RANGE

**Netti V** wheelchair is designed for temperature range of -10°C to +40°C.

## 1.5 INFORMATION FOR RE-USE

All products from Alu Rehab are designed to give years of little maintenance service. All products can be adapted for re-use by an authorised dealer. In order to guarantee performance and safety, Alu Rehab recommends the following tests prior to any re-use.

Please examine the following components for function, integrity etc. and replace parts if necessary:

- Wheels (tyre tread) and quick release
- Wheelchair frame
- Front castors and quick release
- Hubs
- Brake function
- Directional stability of wheels
- Bearings: test for wear and lubrication.
- Cushions
- Leg supports
- Arm supports
- Recline / tilt function
- Push bar / handles
- Anti tip

If electrical functions are mounted, please check:

- Batteries - may need to be replaced
- Control box
- Charging point and all connectors
- Joystick
- Electrical functions of all actuators

For hygienic reasons: please replace the head support cover for a new user.

Please also note the contents of Section 9.2 Cleaning and care



A refurbishment manual for Netti Wheelchairs can be downloaded at [my-netti.com](http://my-netti.com)



A recycling manual for Netti Wheelchairs can be downloaded at [my-netti.com](http://my-netti.com)

Illustrations may differ from product.

## 1.6 ABOUT THIS MANUAL

In order to avoid damages while using the **Netti V** wheelchair, please read this manual carefully before starting to use the chair.



**Symbol of forbidden actions.**  
No warranty can be claimed whenever these actions are implemented.



**Symbol of warning.**  
Whenever this symbol is used, caution has to be taken.



**Symbol for important information.**



**Symbol for useful tips.**



**Symbol for tools.**



**Symbol for:**  
Max safe slope for hand brake.



**Max.**  
135 kg **Symbol for: Max user weight.**



**Medical Device**



**Manufacturer - Name and address**



**Date of manufacturing**



**Serial number**



**Read user instruction**

Please note that this manual is updated according to the year and date stated on each page.

Instruction for use on web - [my-netti.com](http://my-netti.com)

For enhanced readability ( advantageous for users with visibility challenges) please find our instruction for use on our web page: [my-netti.com](http://my-netti.com) - manuals - instruction for use **Netti V**.

Latest instruction for use updates, product safety notes, addresses and other product information like recalls etc. will be published on our webpage.

## 1.7 VITAL MEASURES

**Netti V** is a multifunctional class B wheelchair designed for indoor and outdoor use.  
Min. dimensions in table refer to seat width 350 mm.  
Max dim refers to seat width 500 mm.

 Specifications varies between countries.

**Total weight: 37 Kg**

(450 mm width chair)

**Seat width**

**350 - 550 mm**

**Frame widths:**

**350, 400, 450, 500 mm**



**Seat depth**

From chairback profile to front of seat plate by seat width 350-500 mm:  
stepless from **400 to 550 mm**

(\*Minimum seat depth can be 375mm with the chair-back in forward mounted position)



**Seat height: 345 - 514 mm\***

From floor to top seat plate dependent on wheel sizes and hole position.



\*With same wheel sizes the seating height can be adjusted in the seat height brackets.

**Backrest height: 515 mm\***

\* Using the back rest extender gives up to 613 mm backrest height.



 For **Netti V** with seat width 500 mm and more, the overall width exceeds recommended 700 mm.

Specification Netti V - seat width 450 mm	min.	max.
Overall length with leg rest – horizontal seat.	1060 mm	1145 mm
Overall width by 24" +7" wheels: 210 mm+seat width	640 mm	-
Folded length	780 mm	780
Folded width (removed wheels)	640 mm	-
Folded height (removed wheels, cushions, arm, head + leg support)	578 mm	648
Total mass	35 kg	37,2 kg*
Mass heaviest part: frame	-	24,8 kg
Mass heaviest component: leg support	2,4 kg	2,4 kg
Static stability downhill		13°
Static stability uphill***	8°	15°
Static stability sideways	15°	15°
Safe slope, use anti-tipper		10°
Seat plane angle	-3°	30°
Effective seat depth	375 mm	550 mm
Effective seat width	450 mm	500 mm
Seat surface height at front with 7" and 24" wheels	386 mm	486 mm
Backrest angle	85°	130°
Backrest height ex cushion from seat plate, max with back extender	515 mm	613 mm
Leg support foot plate to seat distance different adjustment profiles	261 mm	500 mm
Leg to seat surface angle	90°	180°
Arm support to seat distance	185 mm	325 mm
Front location of arm support structure - adjustable	300 mm	430 mm
Push rim diameter	535 mm	535 mm
Horizontal rear wheel axle location	-10 mm	95 mm
Parking brake max slope	-	7°
Minimum turning radius, vertical leg supports	R 666 mm	702 mm

\*Model with 24" main wheels, angle adjustable leg supports and head support D.  
Measured without cushions.



If in doubt - contact your dealer!

## 2. QUICK REFERENCE

The content of this page is a summary of the whole manual. It gives you a brief introduction to the use and care of the **Netti V** wheelchair.

 The quick reference is not a replacement for the manual, only a reminder/check list.

- Unpack the wheelchair (Chapter 5.1)
- Mount the main wheels (Chapter 5.3)
- Mount the front castors (Chapter 5.3)
- Rise the back rest and mount the recline gas strut to the back rest using the locking bolt. (Chapter 5.5)
- Mount the arm supports (Chapter 5.7)
- Mount the cushions (Chapter 5.4 and 5.5)
- Mount the leg supports (Chapter 5.9)
- Adjust the push handles (Chapter 6.6)
- Mount the head support (Chapter 5.6)
- Mount accessory. (See chapter 5 for more information. Mounting descriptions will follow the accessory.)
- If electrical functions are mounted: Connect the battery, charge and start electrical functions

 Adjust the wheelchair to the user: Adjust seat depth, foot plate height, armrest height, head support height and depth, chair back cushion height and eventually the wheelchair balance,

For more information about adapting the wheelchair to the user please see [my-netti.com](http://my-netti.com) knowledge and tools

 For troubleshooting, see chapter 11. For adjustments see chapters 5.

 **ANTI-TIP** will secure the chair from tipping backwards as long as they are in use.

 Drive carefully!

 Be sure to lock all handles properly.

 Watch out for pinching danger when folding and unfolding, tilting, reclining and all other adjustment movements.

 Never stand on the foot plates due to risk of tipping forwards.

 The anti-tips are always used for the safety of the user.

 When the chair is tilted rearwards the anti-tips must be activated. The brakes must be locked when leaving the user in the backwards tilted position.

 Never lift the wheelchair by the leg supports, arm supports or head support.

 Be aware that friction against push-rims can create a warm surface.

 Surface temperature of metal parts in frame structure might increase when exposed to direct sunlight.





 Salt water can increase risk of corrosion. Further precautions related to environmental conditions not needed.

 If electrical functions are mounted: Charge the battery daily.

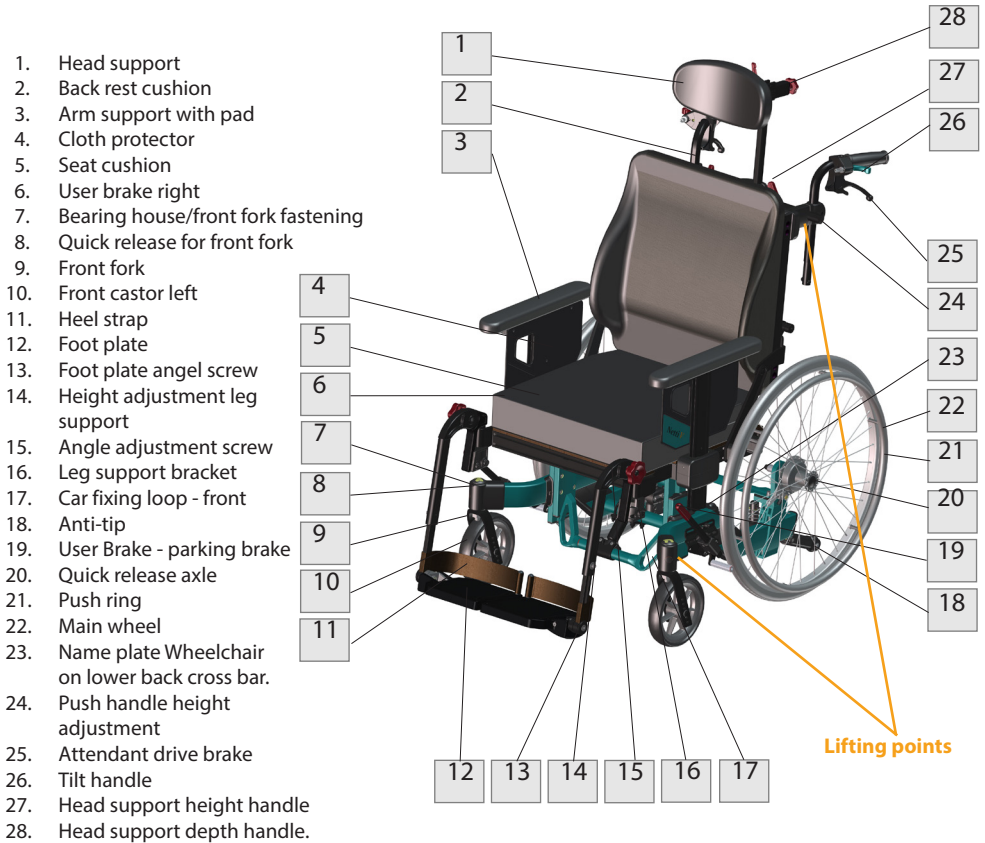
 If the chair has pneumatic tires: Make sure to check tyre pressure every week and inflate to keep 24" wheels at 45 PSI, and 7" wheels at 36 PSI.

### 3. DESCRIPTION\*



-  If any of these parts are missing, please contact your dealer.
-  For complete information, please contact your dealer.
-  Be aware that specifications may vary between countries.
-  Be aware that illustrations and pictures may differ from your received product.
-  For visually impaired people, manuals and catalogues can be downloaded at [my-netti.com](http://my-netti.com)

### 3.1 INFORMATION ABOUT THE NETTI V SYSTEM

**Netti V** is an advanced mobility aid incorporating a range of adjustment solutions allowing optimum adjustment to the user:

**Seat height:**

**Netti V** has a unique seat height mechanism allowing for 70 mm seat height adjustment independent from wheel size and wheel position.

**Seat width:**

**Netti V** has a unique seat width adjustment range - allowing for actual 25 or 50 mm seat width extension by moving: the arm support 25 or 50 mm outwards, the chair-back 25 or 50 mm outwards, the leg supports 25 or 50 mm outwards

**Seat depth:**

**Netti V** seat depth can be adjusted from seat depth 375 to 550 mm. The seat plate itself can be regulated stepless 150 mm (by seat depths 400-500mm).

**Chair-back width and shape:**

**Netti V** chair-back can be adjusted to a A shape = wide hips or V- shape = broad shoulders in addition to the 25 or 50 mm width adjustment.

**Head support position:**

**Netti V** is suitable for all Netti head supports with step-less sideways adjustments in addition to the height and depth adjustment.

**Tilt range:**

**Netti V** wheelchair frame allows for extensive tilt range from 3° forwards to 30° backwards independent from seat height.

**Recline range:**

The **Netti V** wheelchair back allows for the back recline from 85 to 130 degrees .

**Balance:**

**Netti V** has a unique system for balancing the wheelchair by moving the whole seating unit 56 mm backwards or forwards. A well balanced wheelchair is easy to drive and stable enough even when tilting.

**Manoeuvrability:**

**Netti V** has a wheel base where the foot print - and thereby the stability and the ease of driving (manoeuvrability of the wheelchair) can be adjusted by adjusting the position of the rear wheel brackets, range -110 mm.

**Netti V** is a narrow chair ensuring easy manoeuvring in narrow spaces. With 24" wheels it is 210 mm wider than the seat width. - with 16" wheels it is only 195 mm wider, The main wheels can be adjusted outwards if extra sideways stability or conflicts between arm supports and wheels requires more space.

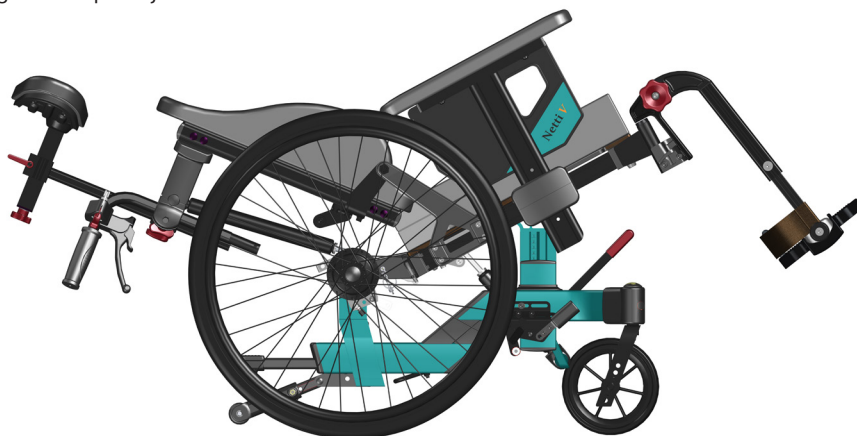

## 4. FEATURES OF NETTI V

### STANDARD CONFIGURATION

#### SEAT

- Netti UNO Seat cushion with good pressure distributing properties
- Tilt -3° to +30°
- Adjustable height 345 - 514 mm by seat height adjustment + change of wheel size and position
- Adjustable depth from 375 - 550 mm

#### WHEELS\*

- 24" x 1" PU main wheels with quick release axle and drum brake
- Push rim: Aluminium
- 7" Puncture proof front castors with quick release axle

Standard main wheels may vary between countries

#### PUSH HANDLES

- Height adjustable

#### BRAKES -

- Attendant and user drum brakes - dependent on country

#### ANTI-TIP

- Foot operated swing away

#### BACK REST

- Netti Uno Back cushion with integrated lumbar support and side support, height adjustable
- Recline angle: 85° - 130° (with recline gas spring more than 750 Newton the recline angle range is 90° - 118°)
- Height: 515 mm

#### LEG SUPPORT

- **Universal** leg supports, which can be angle adjusted, swing-able, removable
- Height- and angle adjustable foot plates
- Heel strap
- Standard leg support may vary between countries

#### ARM SUPPORT

- Height adjustable
- Removable
- Depth adjustable pads

### OPTIONS /ACCESSORIES

#### SEAT

- Trays & reading stand for trays (See chapter 5)
- Hip belts and 4 point belts harnesses (See chapter 5)
- Abduction block

#### WHEELS

- 16" Puncture proof wheels with drum brake and bracket.
- 20", 22" and 26" PU wheels
- 5", 6", 7" and 8" front castors.
- Pneumatic front castors (See chapter 5)
- Spoke protectors (See chapter 5)
- Push rims (See chapter 5)

#### BACK REST

- Back rest cushions - different models
- Back rest extender
- Side support Correction
- Dynamic back cylinder inclusive Evoflex hip belt.
- H-belt attachment rack
- Pelvic Stabilizer

#### LEG SUPPORTS

- Angle adjustable
- Dynamic leg supports
- Grandis leg supports
- Grandis fixed angle

#### ARM SUPPORT

- Different pads (See chapter 5)
- Hemi armrest and Hemi cushion (See chapter 5)

#### NETTI HEAD SUPPORTS

- Height, depth and angle adjustable - several models.
- Removable
- Dynamic head support

NETTI V is defined in 4 different configurations. Configurations may vary between different markets according to market agreements. This instruction for use will however cover IFU (instructions for use) for all listed configurations.

## Configuration

### Netti V All-round

#### SEAT

- Netti UNO Seat cushion with good pressure distributing properties
- **Tilt angle operated by the user: -3° to +20°**
- Adjustable height 345 - 514 mm by seat height adjustment + change of wheel size and position
- Adjustable depth from 375 -550 mm

#### WHEELS

- 24" x 1" PU main wheels with quick release axle and drum brake
- Push rim: Aluminium
- 7" Puncture proof front castors with quick release axle

Standard main wheels may vary between countries

#### PUSH HANDLES

- Height adjustable

#### BRAKES -

- User brakes

#### ANTI-TIP

- Foot operated swing away

#### BACK REST

- Netti Uno Back cushion, height and side adjustable
- Recline angle: 85° - 130°
- Height: 515 mm

#### LEG SUPPORT

- **Universal** leg supports, which can be angle adjusted, swing-able, removable
- Height- and angle adjustable foot plates
- Heel strap

#### ARM SUPPORT

- Height adjustable
- Removable
- Depth adjustable pads

## Configuration

### Netti V EL

#### SEAT

- Netti UNO Seat cushion with good pressure distributing properties
- **Electric regulated Tilt angle -3° to +30°**
- Adjustable height 345 - 514 mm by seat height adjustment + change of wheel size and position
- Adjustable depth from 375 -550 mm

#### WHEELS

- 24" x 1" PU main wheels with quick release axle and drum brake
- Push rim: Aluminium
- 7" Puncture proof front castors with quick release axle

Standard main wheels may vary between countries

#### PUSH HANDLES

- Height adjustable

#### BRAKES -

- Attendant and user drum brakes

#### ANTI-TIP

- Foot operated swing away

#### BACK REST

- Netti Uno Back cushion with integrated lumbar support and side support, height adjustable
- **Electric recline regulated angle: 90° - 118°**
- Height: 515 mm

#### LEG SUPPORT

- Electric angle operated leg supports,
- Height- and angle adjustable foot plates
- Calf supports

#### ARM SUPPORT

- Height adjustable
- Removable
- Depth adjustable pads

## Configuration

### Netti V Base

#### SEAT

- **No cushion**
- **Tilt angle:** -3° to +30°
- Adjustable height 345 - 514 mm by seat height adjustment + change of wheel size and position
- Adjustable depth from 375 -550 mm

#### WHEELS

- 16" PU main wheels with quick release axle and drum brake
  - Push rim: Aluminium
  - 7" Puncture proof front castors with quick release axle
- Standard main wheels may vary between countries

#### PUSH HANDLES

- Height adjustable

#### BRAKES -

- User brakes

#### ANTI-TIP

- Foot operated swing away

#### BACK REST

- No backrest mounted. Prepared for mounting various back supports / moulded seating solution

#### LEG SUPPORT

- Universal leg supports, which can be angle adjusted, swing-able, removable
- Height- and angle adjustable foot plates
- Heel strap

#### ARM SUPPORT

- Height adjustable
- Removable
- Depth adjustable pads

Cross tube with brackets - Netti V Base

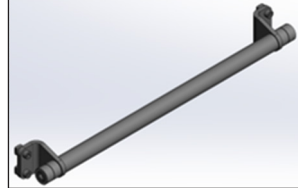

Netti V Base shown without arm- and leg supports.



The total weight of the user plus seating unit, accessories and extra equipment must not be more than 135 kg.

## 4.1 ACCESSORIES

**i** The anytime updated complete accessory program is found on our web page [my-netti.com](http://my-netti.com)

**i** Not all accessories are available for all wheelchair configurations. Please check the home-page or ask customer service for further details.

### Belts

Several models:  
Hip belts with or without upholstery and with plastic lock or car lock.



### H-Belt attachment rack

To be mounted on to the push bow brackets.



### Trays

4 models:  
Swing-able, lockable and standard "push on" + half-tray.



### Upholstery for tray

Offers a soft base for the arm resting on the tray.



### Wedge

Increases side support.



### Lumbar support

Increases lumbar curvature.



### Back rest Cushions

Many to choose from.  
Please contact your dealer.



### Seat Cushions

Many to choose from.  
Please contact your dealer.



### Leg supports

Universal leg support



Angle adjustable leg support



Grandis angle adjustable



Grandis fixed angle

Adjustable in fixed positions between 0° (horizontal) to 96° using an Allen key.



### Grandis extension piece -

Required for mounting of any Grandis leg supports



**Back rest extender**

Increasing back height with ca 100 mm

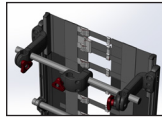

**Hygiene cover**

Protects the core of the head support.



**Head supports**

Support A Side support also available with forehead strap

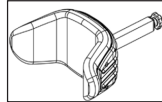

**Hemi cushion**

A more accommodating support than the hemi arm support.



Support B Small

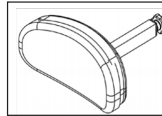

Support C Large

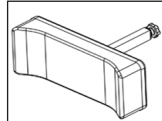

**Arm support pads**

Wide: 385 x 58 mm

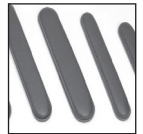

Support D comfort pressure distributive

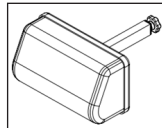

**Hemiplegic arm support**

Inward swing-able



Support E adjustable side supports

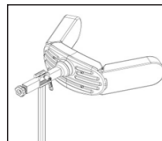

**Side support Correction**

Meant for correction of unfavourable postures in the upper trunk.



Support F with cheek/chin support band

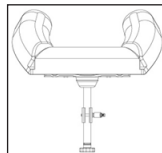

**Side support Stabil**

**Abduction block**

The block reduces abduction.

- Small: 80 mm width
- Medium 110 mm width
- Large: 140 mm width



**Head cushion**

**Comfort**

Cushion with Kospoflex filling to pull onto head rest.



**Pelvic positioner guide**

also to be used as knee support.



### Foot board with lock

The leg supports can be swung to the side like standard leg supports.



### Calf support and Upholstery for calf support bracket

Reduces pressure.



### Push bow

Sizes following seat width.



### Main wheels

available in sizes:  
16" with drum brake  
20", 22", 24" and 26"  
with or without drum brake.  
Puncture proof Flexel or PU.



### Spoke protectors

For 24".  
Black or transparent is optional.



### Push rims Aluminium:

### Friction push rim

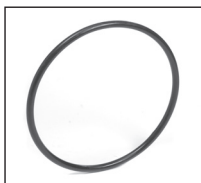

### Front wheels / castors

available in sizes:  
5", 6", 7" & 8"

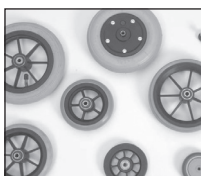

Wheel frame extender for rearward and height adjustment 16" main wheels is part of:

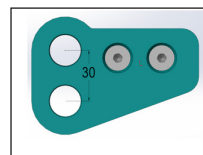

### 16" wheel kit with bracket.



Gas spring movement limiter

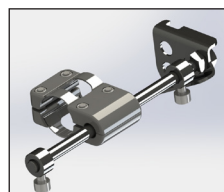

### Tool kit



Netti V is prepared for:

El-kit with electrical tilt and recline functions + electric operated leg supports.



- Mounting assistive motors
- Mounting moulded seating
- Mounting universal device rack.



# 5. ASSEMBLING AND ADJUSTING

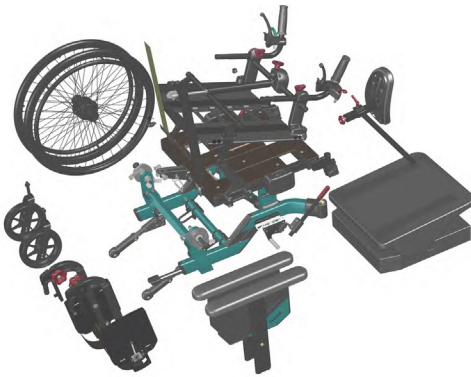

## 5.1 UNPACKING

(See chapter 5 & 6 for details for mounting)

- 1. Unpack all the parts, and check that everything is delivered according to the packing list.
- 2. Mount main wheels and front castors.
- 3. Mount the back rest gas spring, arm supports, cushions, head support and leg supports.
- 4. Mount accessories.

### Weight of components (450 mm chair width):

Drive wheels:	1,8 kg each
Front castors:	0,9 kg each
Leg support Universal left:	1,3 kg
Leg support Universal right:	1,3 kg
Netti Uno Back:	1,2 kg
Netti Uno:	1 kg



Necessary tools are described under each chapter.



Accessories described in chapter 4 are a presentation of options, and will be delivered with separate mounting descriptions.



When adjustments of seating and wheel positions are done in the possible positions by standard equipment, the adjustments will not exceed safe limits.

## 5.2 INITIAL ADJUSTMENTS TO THE USER - OVERVIEW

Start with user sitting in a normal upright position.

### SEAT ADJUSTMENTS

It is vital to adjust the seat correct to give the user the support for his /her whole body. Adjustments to the seat may change the centre of gravity which effects the balance of the wheelchair. Proper adjusted seat provide stability and the ability to manoeuvre the wheelchair safely.

**Correct seat width depends on the user's hip width. It is measured while seating.**

- The seat width is defining the wheelchair size when ordering. If another seat width - due to change of body size or by change of user, the **Netti V** seat width can be increased with 25 or 50 mm.

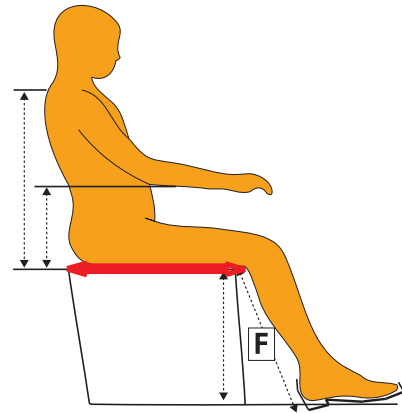

**Correct seat depth depends on the user's thigh length. It is measured while seating - see the red horizontal arrow on the illustration.**

- The seat depth is adjusted in the seat plate by slightly loosening the 3 screws holding it and extending or shorten it to desired depth from 400-550 mm. For extra short seat depth - 375 mm, the back hinge can be moved 25 mm forwards.



The relationship between seat angle and backrest angle should be kept constant when the tilt function is used to create variation for the user.

### Correct seat height

The seat height is to be adjusted according to how the wheelchair shall be used:

- When driving with the push rims or being driven by an attendant the seat height is to be adjusted along with the leg supports. The leg support foot plates must have ca 30 mm free space underneath.
- When foot propelling - the seat height shall be adjusted for the user to have his/her feet flat on the floor.

Seat height depends on the user's calf length and is measured while seating - see the dotted vertical F-dimension on the illustration.



Please note: the Netti leg support adjustments are described in detail in chapter 5.10.



Please, see the drawings on next pages regarding seat depth adjustments.



Information regarding screw tightening torque is supplied at the end of this manual.

## 5.3 WHEELS ASSEMBLING

### 5.3.1 DRIVE WHEELS

To mount the drive wheel remove the quick release bolt from the hub bushing, lead it through the centre of the main wheel and into the hub bushing while pressing the knob in centre of the quick release.

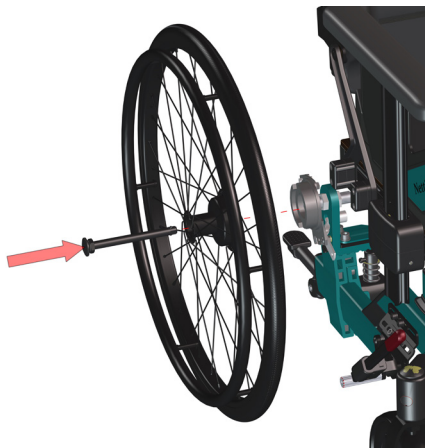

To check that the drive wheel is properly attached to the hub, remove the finger from the central knob and pull the main wheel.



If the drive wheel does not lock, see chapter 5.3.3 and adjust.



If the drive wheel still does not lock, do not use the wheelchair but contact your dealer.



Sand and sea water (salt used for gritting in the winter) can damage the bearings of the main wheels. Clean the wheelchair thoroughly after exposure.

Following main wheels are available: 16", 20", 22", 24" and 26". Choice of main wheel size and position in the wheel bracket - see table page 31 allows for different driving characteristics such as hand propelling or attendant drive and seat height adjustments.

### 5.3.2 CORRECT FRAME ANGLE

To ensure good driving characteristics you need to check and adjust - with drive wheels and front castors mounted - that the lower frame is horizontal and the front castor bearing house is vertical. See dotted red lines.

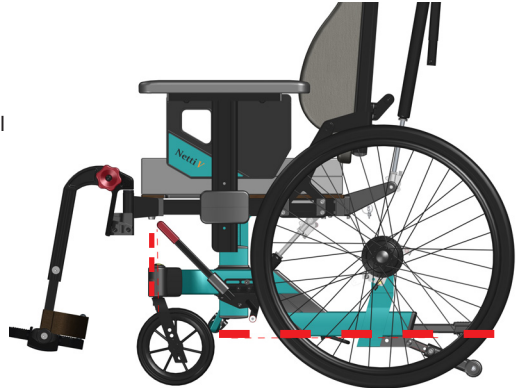

### 5.3.3 MAIN WHEEL QUICK RELEASE

The quick release axle links wheel and frame. The nut sitting under the head of the quick release axle can be adjusted to fit the axle tightly when inserted into the frame.

Adjust the nut backwards towards the axle head if the axle does not click in .

Adjust the nut forwards if the axle sits loose when inserted through wheel and brake.

 Open end spanner 19 mm

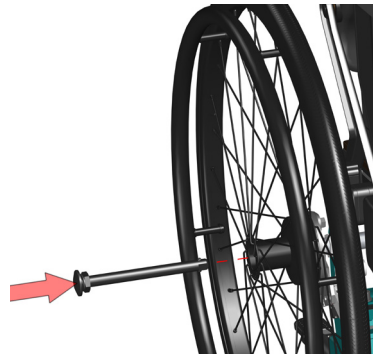

### 5.3.4 MAIN WHEEL WIDTH POSITION ADJUSTMENT

The main minimum wheel width position is seat width + 210 mm with 24" whels. The width can be increased in steps by repositioning of the upper main wheel brackets.

It can also be adjusted by adjusting the positioning of the main wheel sleeves.

Adjustments of the main wheels width position is required when:

- increased side stability is required
- the seat width adjustments are made
- there are conflicts between components and the wheels.

### 5.3.5 REPOSITIONING OF THE MAIN WHEELS - OUTWARDS

#### THE MAIN WHEEL BRACKET

- Loosen the 2 M8 screws enough to lift the cross-profile and the main wheel bracket high enough for the bracket to be stepwise sideways moveable.
- Move the bracket to desired width.
- Tighten the screws well.
- Repeat on the other side.
- Check that the main wheels have the same sideways position on both sides.



1 pc 6 mm Allen key.

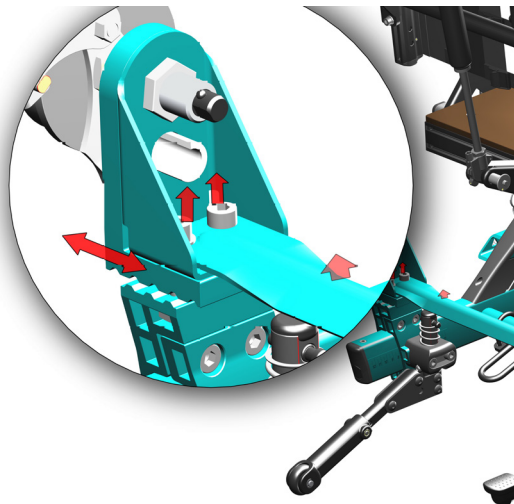

#### THE MAIN WHEEL SLEEVE

- Loosen the hub bushing, including washer and nut
- Mount it in required position in the main wheel bracket.
- Adjust the drum bake arm to closes position.



2 pc 24 mm open-end spanner



Make sure that the nut on inside of frame totally wreathes the wheel bushing.



The risk for tipping increases when the main wheel is moved forward in the main wheel bracket.



Check the position of anti tip.



Readjust the brakes.  
(See chapter 5.3.11-12).

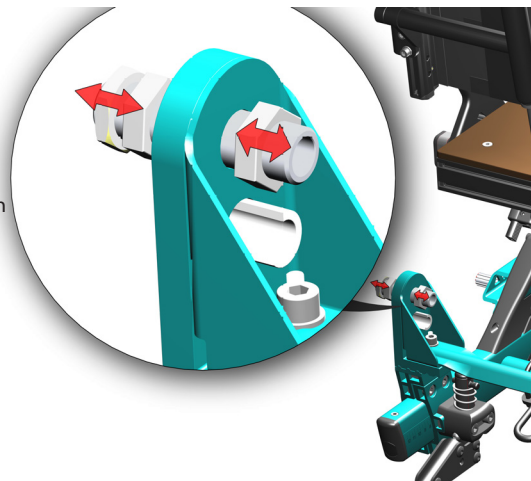

Adjust the user brakes according to the wheel position and size. Chapter 5.3.11 and 5.3.12

### 5.3.6 REPOSITIONING OF THE MAIN WHEELS FOR- AND BACKWARDS

The wheel position (factory setting) is set at a point where the wheelchair has good driving characteristics and is stable even when tilting.

It is possible to adjust the wheel distance by repositioning the main wheel bracket on the frame. When adjusting the rear wheel position, the stability of the chair is changed. If adjusting to shorter wheel footprint than position 8 for main wheels, the chair may become unstable and special precaution must be taken. Adjust the anti-tippers (chapter 5.3.7) to reduce instability. Always use the anti-tippers.

#### MAIN WHEEL BRACKET

2 of the 4 screws holding the main wheel bracket sits behind the anti-tip.

Remove the anti-tip - see chapter 5.4.3

- Loosen the 4 M8 screws holding the main wheel bracket around the frame - on both sides.
- Loosen the 2 upper screws holding the crossbar to make the sliding more easy.
- Slide the brackets forwards or backward to desired position.
- Tighten the screws well.
- Make sure the position is identical on the brackets on each side; a scale on the frame makes it easy to identify.

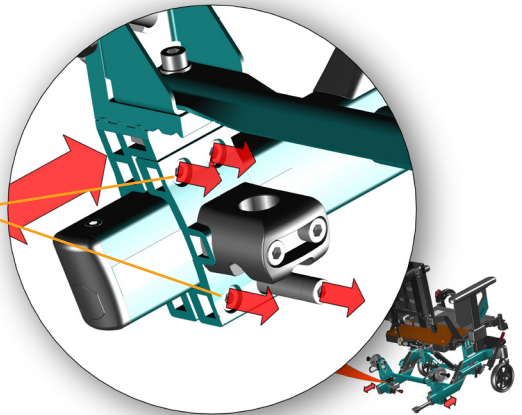

**1 pc 6 mm Allen key.**

- Mount the anti-tips
- Mount the main wheels



Let the wheelchair roll forwards and check that it keeps a straight line. If it waver off to one direction, the main wheels position need adjustment.

#### 16" WHEEL EXTENDER

is required to get horizontal wheel frame.

- Remove the wheel hub
- Mount the extender in its place



**1 pc 16 mm and  
1pc 17 mm open-end spanner**

- Mount the wheel hub to the extender.

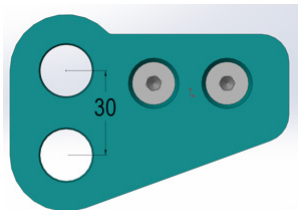

Information regarding wheel positioning of front castors and anti-tips is found at the end of this manual.

### 5.3.7 ANTI-TIPS

**Netti V** has foot operated swing-away anti-tips. They follow the main wheel position and will normally be in correct position.

How to operate:

- Push the anti-tip down
- Swing it inward, it will snap into position.

To swing it out

- Push down a little and pull it backwards. It will snap into active position.

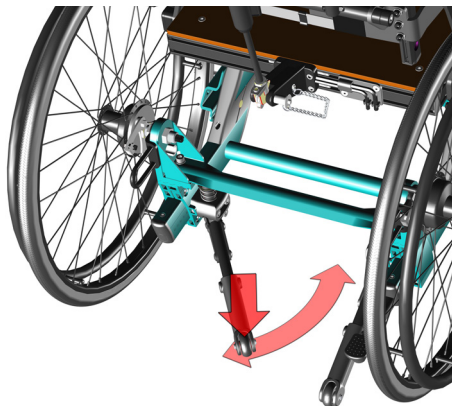

The anti-tips can be length adjusted by repositioning the end piece. Remove the screw **(A)** and position in required hole.

The anti-tips can be angled adjusted by repositioning the rear screw. Remove the screw **(B)** and position in required hole.

-  1 pc 5 mm Allen key

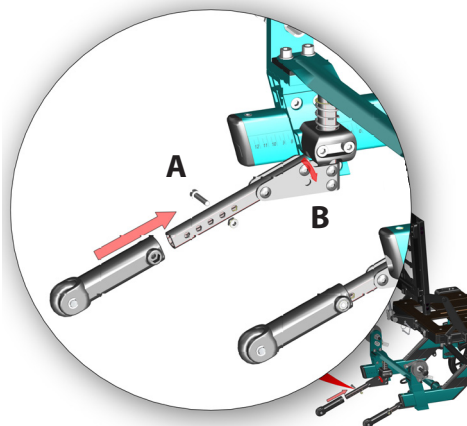

The anti-tips can easily be removed:

The anti-tips must be removed when the main wheel bracket shall be repositioned.

- Push down the spring
- Pull out the splint (A) sitting on top of the anti-tip
- Pull down the anti-tip.

-  Always check the anti-tip height. It may be necessary to adjust to get desired distance from anti-tip wheel to the ground - ca 30 mm.

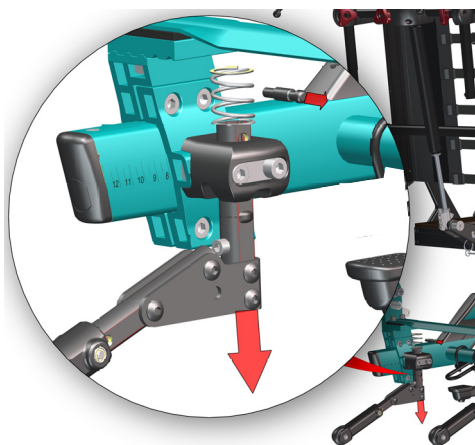

### 5.3.8 STEPPER PEDAL ADJUSTMENT

**Netti V** has a stepper pedal for the ease of tipping the wheelchair when passing obstacles.

The pedal is positioned according to the main wheel position. When the main wheel position has been adjusted it is recommended to adjust the length of the tramp pedal. It can be moved up to 125 mm.

- Loosen the M5 screw underneath the frame - see picture. Do **not** unscrew this screw!
- Position to desired length.
- Tighten the screw well.



1 pc 4 mm Allen key

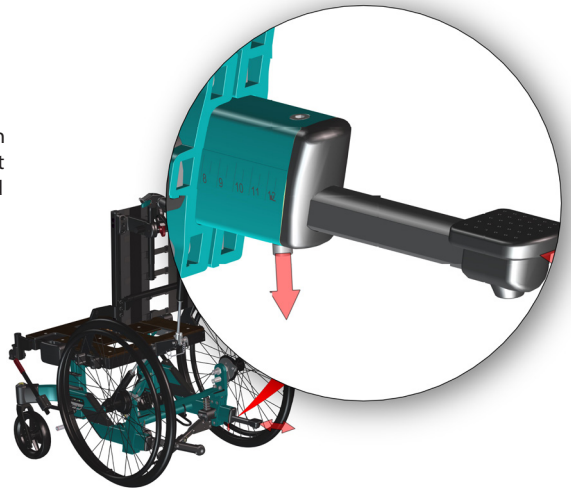

### 5.3.9 FRONT FORK

Front forks come as standard with quick release axles. The front fork is easily removed by pressing the quick release button on top of the bearing house.

### 5.3.8 CASTOR POSITION IN FRONT FORK

Mount the front castor in the hole of the front fork where the wheelchair frame is horizontal. Thereby the front fork is vertical and give good driving quality.

- Repeat on the other side.



2 pc 13 mm open-end spanner.



Choice of drive wheel size and position requires adjustments of the front castor position in the front fork. See table at the end of this manual

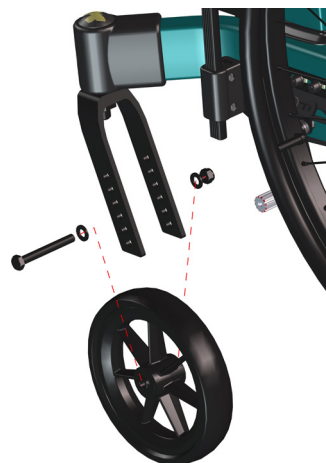

### 5.3.10 FRONT CASTORS

#### Removal

- Press the release button on top of the front fork bearing house - by pressing on the silicon cap covering the release button.

#### Mounting

- Lead the quick release axle into the bearing house and into the front fork.
- Pull the fork slightly to ensure that the fork is fully locked.



Sand and sea water (salt used for gritting in the winter) can damage the bearings of the front castors. Clean the wheelchair thoroughly after exposure.

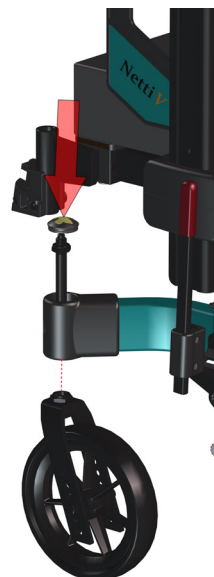

### 5.3.11 THE BRAKES

The **Netti V** is fitted with

- attendant running drum- and parking brakes
- user knee-lever parking brakes direct on the tires.

#### Operating and applying the attendant brake

The 2 hub brake handles for the drum brakes, which allow regulation of speed on hills and whilst travelling along are located on the push handles.

- To apply the brakes, pull the brake levers (1) evenly and smoothly towards the handles.
- To activate the drum brakes for parking, push the little lever (2) on the brake handle downwards while you hold the brake handle pulled.
- Next time you pull the brake lever the parking function is release.

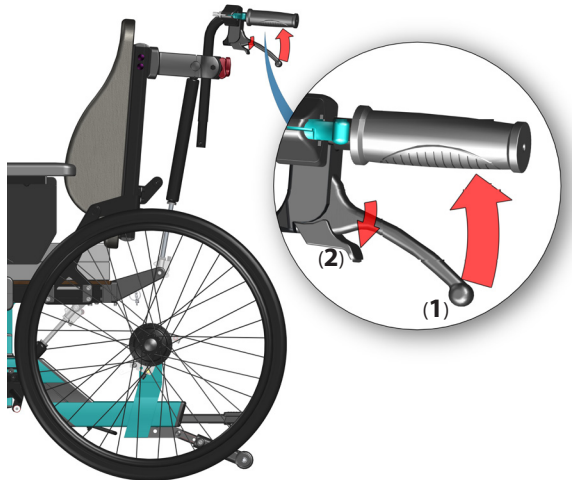



#### Operating and applying the user brake / parking brake

The wheelchair is fitted with hand operated user parking brake, one on each side on the main wheels.

To activate the parking brake:

- Pull each parking brake handle backwards, .
- To release the brakes: push the handles forwards.

 The user parking brakes cannot be used as running brakes.

 Do not leave the user in the wheelchair without activating the parking brakes.

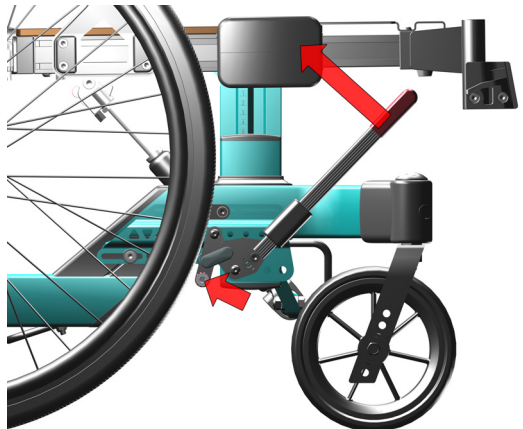

### 5.3.12 USER BRAKE ADJUSTMENT

The user brake bracket is fixed to the wheel-frame with 3 screws. The brake bracket position can be adjusted forwards- backwards by loosening these screw. The brake bracket can be sideways adjusted by repositioning the spacers sitting on the same screws. This may be necessary when the main wheel position is enlarged.

**IF THE BRAKE DOES NOT BRAKE PROPERLY:**

**Alternative 1:**

Adjust the brake-brackets sitting on the wheel-frame backwards or forwards till the distance between the braking bolt (B) and the tire is ca 3-5 mm. Test that the braking function is sufficient without being too hard to activate for the user.

 **5 mm Allen key (A)**

**Alternative 2:**

Adjust the brake sitting on the brake-bracket, 4 possible positions.

The brake handle angle can be adjusted by repositioning the screw (C)

The length of the brake handle can be adjusted by loosening the screws (D) and push or pull the handle to desired length. Tighten well.

 **3 mm Allen key (D)**

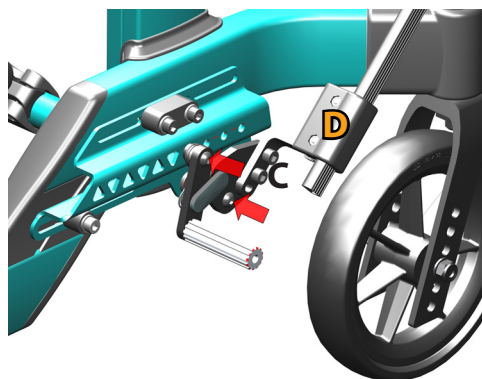
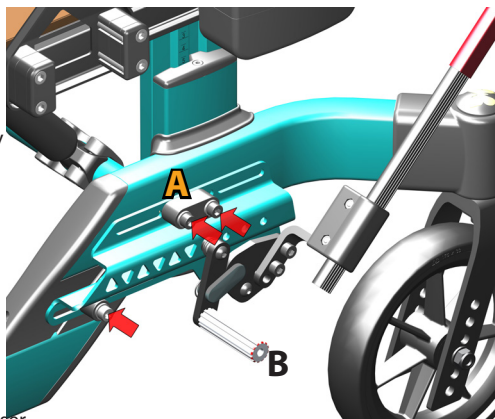

### 5.3.13 DRUM BRAKE ADJUSTMENT

If the drum brake does not brake properly:

Adjust the wire on one or both sides, adjust the foot screw 2-4 rounds out. Then re-check the brakes.

If the wire is too loose:

Adjust the foot screw all the way in. Tighten the wire by loosening the wire clamp before pulling the wire further through it. Tighten the wire clamp, and adjust the foot screw out again

 **1 pc 10 mm open-end spanner.**

 To ensure the correct functions of the wire, these must never be taut.

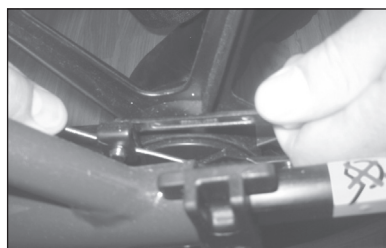
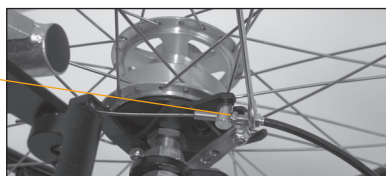

## 5.4 SEAT ASSEMBLING - WHEELCHAIR SEAT HEIGHT

Correct seat height is based on a combination of identified intended use (foot propelling or hand propelling) and the size of the user (leg length).

### 5.4.1 SEAT HEIGHT

The seat height depends on:

- The size of the main driving wheels
- The position of the driving wheels in the main wheel brackets.
- Size of front castors.
- Position of front castors and size of the front fork.
- The height of the seat adjustment bracket.

### NETTI V SEAT HEIGHT ADJUSTMENT BRACKET

allows for 70 mm height adjustment - independent from the choice of wheel dimensions and position.

- Loosen the 4 screws ( do not unscrew) in the bracket on each side.
- Adjust the seat height according to defined seat height for the user.
- Check that the seat height is identical on both sides on the scale on the outside of the brackets





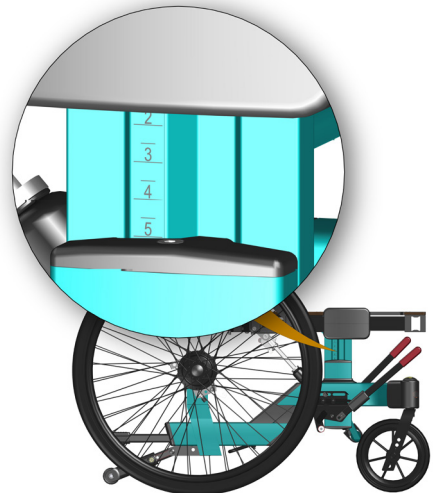







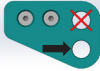



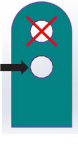

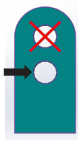
**1 pc 5 mm Allen key**

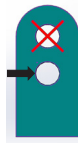

## 5.4.2 NETTI V SEAT HEIGHT TABLE AND WHEEL POSITIONS

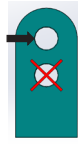
Measured to top of seat plate. Use the open hole for the wheel. Seat height adjustment bracket allow for the varying the seat height with 70 mm keeping the same wheel position.

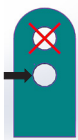
The wheelchair frame **MUST** be horizontal - front wheel height adjusted in the fork.

Front fork position	FRONT wheels	REAR wheels	Seat heights
	7"	16"	 386-456 mm
	5"	20"	 345 - 415 mm
	7"	22"	 390 - 460 mm
	7"	24"	 416 - 486 mm
	7"	24"	 386 - 456 mm
	8"	24"	 415 - 485 mm
	8"	26"	 414 - 484 mm  The main wheels need to be placed in the most backward position.
	8"	26"	 444 - 514 mm  The main wheels need to be placed in the most backward position.

### 5.4.3 NETTI V SEAT PLATE

The Netti V seat plate is an advanced seating platform developed to give persons sitting long time support and stability.

#### SEAT DEPTH ADJUSTMENTS

Seat depth adjustments are done to give the user a comfortable seating position with support under the thighs while having proper lumbar support and the knee joints are aligned with the leg support knee joint.

The seat depth can be step-less adjusted from 400 mm to 550 mm by extending the seat plate. When seat depth 375 is required the back hinge is moved 25 mm forwards.

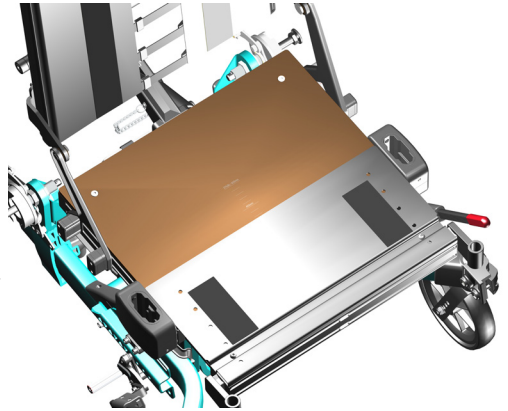

#### Adjusting the seat depth in the seat plate

- Underneath the seat plate: loosen 2 screws holding the front seat frame ( max 3 turns).
- Pull or push the front seat-plate-frame to reach the desired seat depth.
- A scale on the seat plate give information about adjusted seat depth.
- Tighten all screws well.

 **5 mm Allen key**

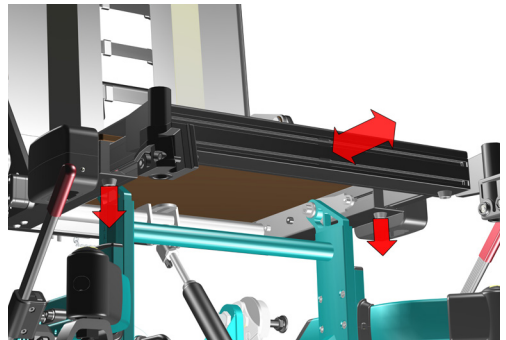

By adjusting the seat depth, the chair balance and the driving characteristics may change. A well balanced chair is easy to drive without easily tipping backwards.

### 375 MM SEAT DEPTH ADJUSTMENT

moving the back hinges / chair-back forwards

For the 375 mm seat depth the seat plate itself is adjusted to 400 mm seat depth - the shortest possible. Where-after the chair-back via moving its hinges is moved 25 mm forwards.

- Remove the covers on the back hinges.
- Loosen- but **do not unscrew** the 4 M6 screws and the 4 M4 screws on each side - holding the chair-back hinge bracket fixed to the seat plate frame - see picture.
- 
- Slide the chair-back hinge 25 mm forwards.
- Adjust identical on both sides.  
A scale indicates position A = standard seat dept and position B = short seat depth
- Tighten all screws well.
- Replace the covers.

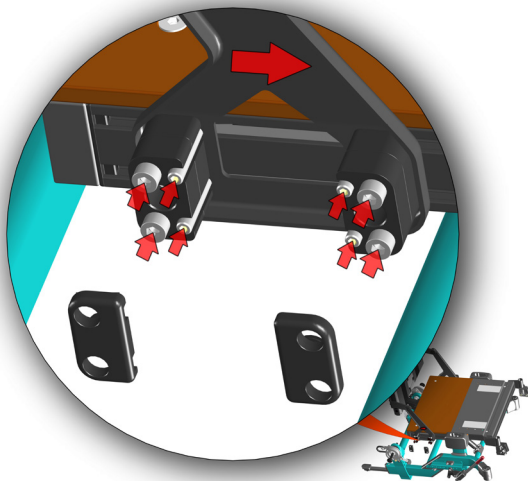

**5 mm Allen key**

**3 mm Allen key**

### 5.4.4 BALANCING NETTI V

The Netti V wheelchair has a unique possibility to balance the wheelchair by:

- adjusting the seat depth to the user
- reposition the seating frame forwards and backwards on the seat frame hinges.

By repositioning the seating unit the weight distribution on the wheels is influenced and thereby the the ease of driving it.

Fig 1

The balancing takes place on 2 steps:

**A)** Adjusting to correct seat depth for the user. This will move his/ hers centre of gravity and the balance of the wheelchair.

- Extend or shorten the seat plate (Chapt 5.4.4)

**B)** Adjust the position of the seating unit on the seat frame hinges, see illustration.

- Loosen 6 pc M6 hex socket screws sitting on the inside of the seat frame side profiles - under the seat plate - 3 on each side (fig 1 &2). Do not unscrew!
- In addition the M6 screw on the bracket holding the gas spring in the rear must be loosened (Fig 3).
- For more easy adjustment loosen the 2 screws holding the front seat frame - with 2 turns (see: seat depth adjustment).
- Pull or push to reposition the seat frame by sliding it on the seat frame hinges.
- A scale on the inside of the seat frame helps adjusting to the same position for the hinge on each side.
- Tighten all screws firmly.

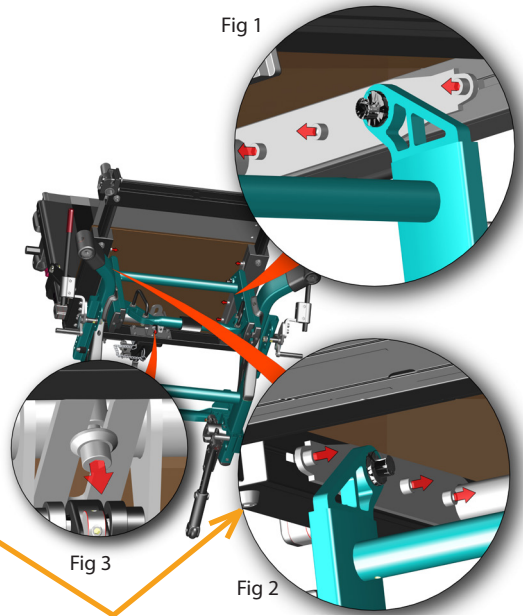

**5 mm Allen key**

Table with recommended starting position for balancing and adjustment.

SEAT WIDTH    SEAT DEPTH    SEAT BALANCE POSITION    REAR WHEEL BRACKET POSITION

350 MM	400 MM		
400 MM	400 MM		
450 MM	475 MM		
500 MM	500 MM		



The point of balance can also be changed by adjusting the seat angle and/or the angle of the backrest.

## 5.4.5 WHEELCHAIR SEAT WIDTH - ADJUSTMENTS

**The Netti V seat width can be adjusted by:**

- 1. Moving the arm supports outwards by 25 or 50 mm
- 2. Extending the chair-back width by 25 or 50 mm
- 3. Extending the leg supports brackets outwards - step-less .

## 5.4.6 SEAT WIDTH - ADJUSTING AT THE ARM-SUPPORTS

- Remove the arm-support bracket covers.
- Unscrew the 2pc 3 mm Phillips screws holding the covers.

 3 mm Phillips key

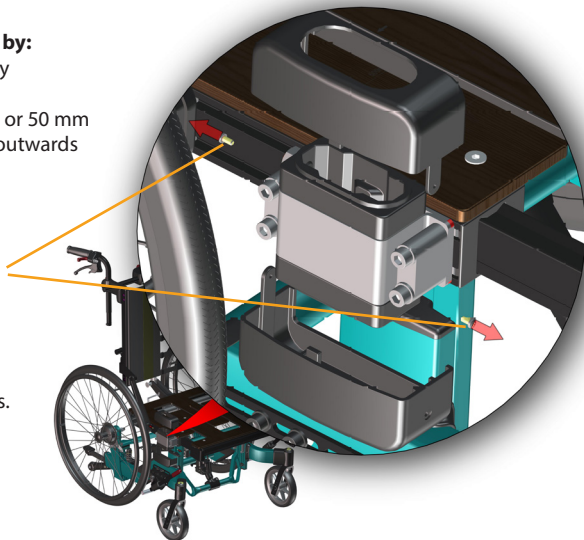





### Move the arm support brackets outwards

- Loosen the 4 M6 mm screws holding the arm-support bracket.
- Remove the spacers sideways - purple illustration.
- Pull the bracket itself more outwards.
- Swap the spacers from the outside of the bracket to the inside of the bracket. Placing 1 pair spacers between the bracket and the seat frame increases the width between the arm supports by 12,5 mm.
- Fix the bracket by tightening the 4 screws - blue as shown in the illustration.
- Mount the covers over the arm support bracket.

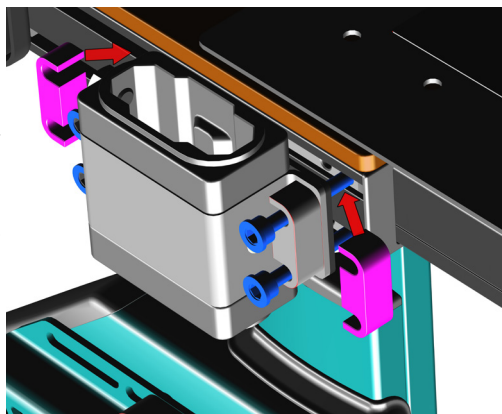
Repeat on the other side.

 5 mm Allen key



-  When one spacer is positioned between the bracket and the seat frame the seat width is increased by 12,5 mm
-  When 2 spacers are placed between the bracket and the seat frame the seat width is increased by 25 mm.
-  When repeated on the other side the seat width is increased by 25 mm or 50 mm.
-  It is recommended to order a new seat cushion when the seat width is increased with 50 mm.



#### 5.4.7 SEAT WIDTH - ADJUSTING AT THE CHAIR-BACK

- Fig 1: Loosen the 2 M6 mm screws holding the push handle bracket.
- Pull the bracket slightly outwards.
- Fig. 2: Unscrew the M6 screw holding the top of the chair-back hinge.
- Hold the spacers sitting on the screw.
- Bend the hinge a little and reposition the spacer on the other side of the chair-back hinge.
- Start screwing the screw back into the cross-tube.
- Fig.3: Loosen the 4 M6 screws holding the chair-back hinge fixture to the seat frame.
- Remove the spacers needed for the planned chair-back width adjustment
- Insert them between the chair-back hinge and the seat frame.

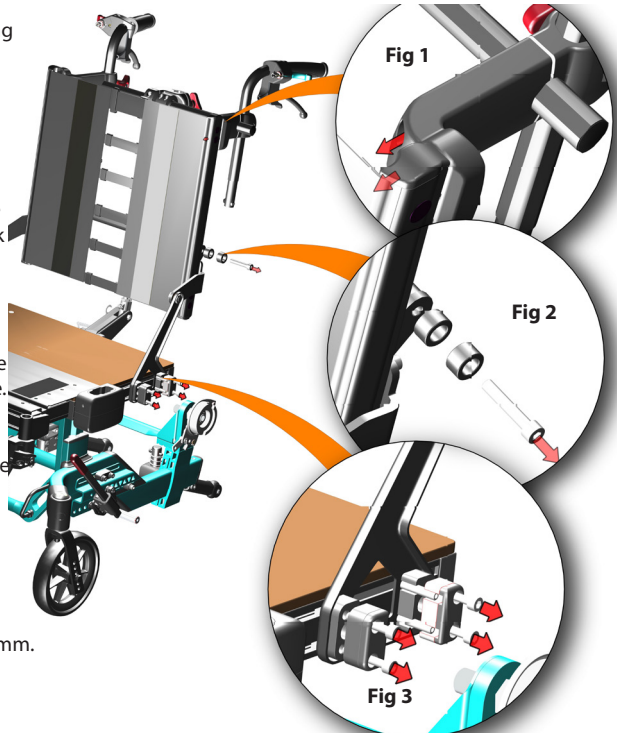

Tighten all screws on both sides well.

- Placing 1 spacer between the chair-back hinge and the seat frame increases the width between chair-back poles by 12,5 mm.

 5 mm Allen key

#### 5.4.8 SEAT WIDTH - ADJUSTING AT THE LEG SUPPORT

- Loosen the 2 M6 mm screws holding the leg support brackets under the seat frame. Do **not** unscrew!
- Pull the leg support brackets outwards to desired width.
- Tighten the screws firmly..



6 mm Allen key



When adjusting the leg support width position the foot plate lock and the foot board lock might not fit anymore. Adjust the locks if possible



If the lock cannot be adjusted to fit, order new leg supports with correct distance between the foot plates according to the new leg support width.



Check that the foot plates or the foot board do not get in conflict with the front castors - also when driving backwards. Adjust the leg support angle and or the seating angle to prevent collision.

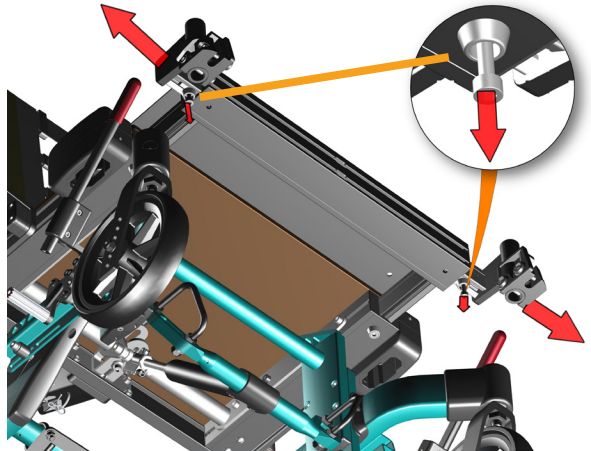

## 5.5 CHAIR BACK ASSEMBLING AND POSITIONING

To mount the recline gas spring:

- Lift the back rest by its push handle with one hand
- Lead the gas spring locking head into the plastic bracket which is sitting on the lower cross beam at the rear.
- Secure the back rest by pushing the locking bolt in from the side, through the bracket and gas spring locking head.

 To check that the back rest is locked, grip the push handle and press the back rest forward.

 If the backrest falls forward - repeat the locking procedure or contact your dealer.

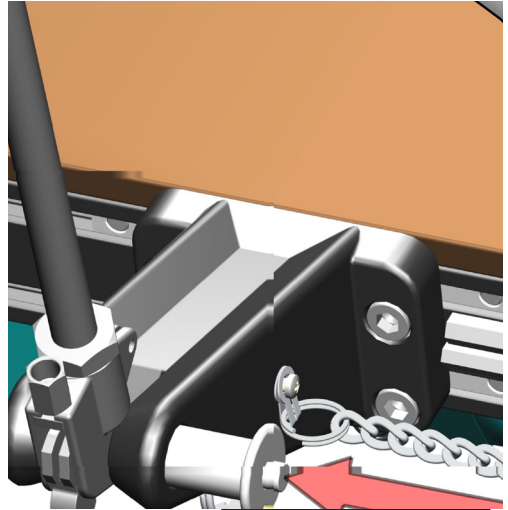

### 5.5.1 ADJUSTING THE VELCRO BACK

- Loosen the straps, and place the back rest cushion so that user gets room for the bottom and the integrated lumbar support in correct position.
- Tighten the straps so that they follow the curvature of the spine and give a little extra support at the top of the sacrum.

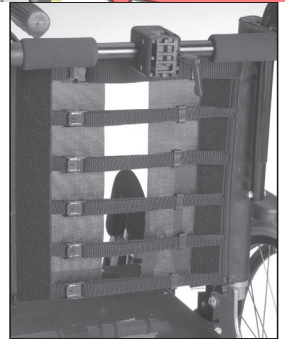

### REPLACEMENT OF THE VELCRO BACK

In case the velcro back needs to be replaced, the back extender, if mounted, is to be removed - see 5.5.3.

- Remove the back profile top cap.
- Loosen the M4x8 mm set screw holding the Velcro - placed on the top inside of the back tube.
- Slide the Velcro up and out of the back profile.
- Mount the new Velcro by sliding it - with plastic rods - into the chair-back profiles.
- Insert the set screw to hold the Velcro in place in the height.
- Mount the back extender.

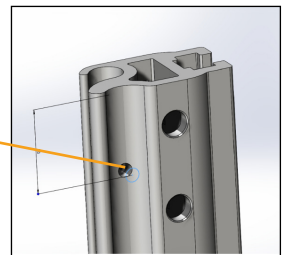

### 5.5.2 BACK SUPPORT TUBES SIDEWAYS ANGLES

The back support tubes can be angled sideways to support a more A-shape (narrow shoulders) or a V-shape (broad shoulders) upper body.

- Loosen the Velcro straps
- Loosen the 2 M6 screws holding the push-bow bracket - fig **A**
- Loosen the upper and the lower M6 mm screws holding the lower back support - fig **B**.
- Loosen the upper and the lower M6 mm screws holding the upper back support - fig **C**.
- Angle the back pole sideways to desired sideways position
- Tighten the screws firmly
- Repeat on the other side.
- Tighten the Velcro straps when the adjustments are finished.

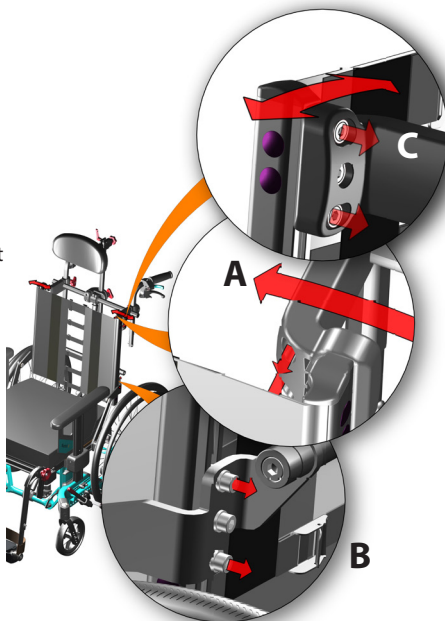

 **1 pc 5 mm Allen key**

### 5.5.3 PLACING BACK SUPPORT CUSHION

The back support cushion is fixed and adjusted on the wheelchair using the back Velcro.

 It is imperative to correctly set-up the seat and back cushions in order to ensure good seating comfort.

 The cushion covers are washable and thereby reusable. Follow the instruction on the back of the cushion for correct maintenance and washing of the cushion.



### 5.5.4 BACK EXTENDER

The back height of **Netti V** is 515 mm measured from the seat plate to the top of the back Velcro. For users taller than ca 1.85 m it may be required to have a higher back for better support around the shoulder region.

Netti **V** is prepared for back extender allowing for increasing of the back height with up to 110 mm. The back extender is mounted by fixing the back extender profiles to the inner side of the chair back tubes with 2 pc screws on each side.

- Remove the 2 buttons on each side.
- Insert the screws through the back tube into the back extender and fix.

Adjust the extender to desired height before tightening.



**1 pc 5 mm Allen key**

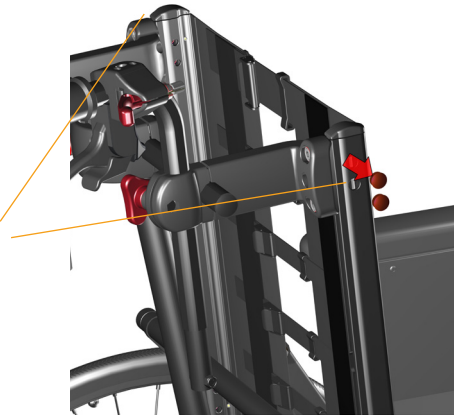

### 5.6. ASSESSMENT AND CHOICE OF BACK SUPPORT GAS SPRING.

The chair back position / recline angle is defined by the chair back gas spring.

INDICATIVE correlation between body weight and suitable recline gas spring force:

Standard delivered is 300 N recline gas spring.

Dynamic gas springs are available with several strengths.

For restless users the Netti V can be equipped with a Dynamic gas spring that allows for the user to recline the back by pushing backwards. The spring will lift the user up to upright seating position when the user does not push any more.

The strength of the gas spring is dependent on the weight, movement pattern and strength of the user.



Always lock the dynamic function of the dynamic gas spring when the chair is used as a seat in a car.

Details regarding dynamic functions is found in the instruction for use for Netti Dynamic System-



### 5.6.1 CHANGE OF RECLINE GAS SPRING

- Remove back cushion and
- Remove the arm supports.
- Remove the back gas spring splint.
  
- Fold the chair-back forwards.
  
- Unhook the wires attached to the gas spring head.
  
- Remove the cylinder by unscrewing it from the gas spring head.
  
  
- Replace the gas spring with a new - with correct strength for the user.
- Mount all parts that was removed.
  
- Adjust the wires.
  
- Fold up the chair-back and test if the solution suits the user strength.

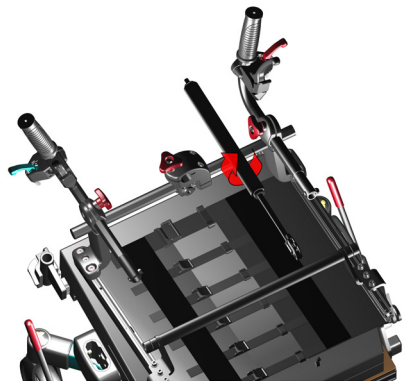
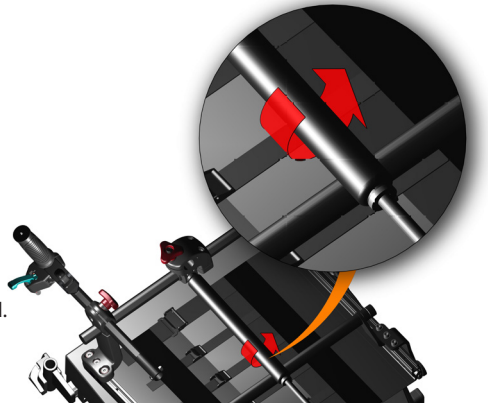

## 5.6.2 CHANGE OF TILT GAS SPRING

The **Netti V** is equipped with 1 tilt gas spring-  
Standard delivered is 450 N tilt gas spring.

Replacement of tilt gas spring:

- Unscrew the spring. It is screwed both at the top and the bottom.
- Loosen the nut on the top of the recline spring. The spring head is still hanging on the chair.
- Replace with the new cylinder.

Screw the new gas spring into the cylinder head and then into the spring bracket.

- Tighten the nut on top.
- Check that the tilt function is working correct.



**1 pc open end spanner**

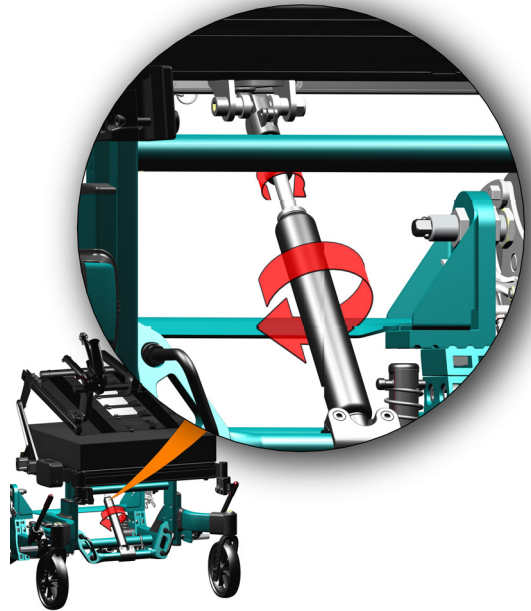

## 5.7 NETTI HEAD SUPPORT ASSEMBLING AND POSITIONING

### 5.7.1 NETTI HEAD SUPPORTS

#### **MOUNTING AND REMOVING**

- To mount the Netti head support, loosen the red triangular star wheel on the push bar.
- Insert the head support rod into the head support bracket.
- Fix at any desired height by tightening the star-wheel.

#### **HEIGHT ADJUSTMENT OF THE HEAD SUPPORT-**

The middle of the head support cushion shall be positioned to meet the head slightly lower than the most rearward part of the head.

#### **DEPTH ADJUSTMENT OF THE HEAD SUPPORT-**

To be adjusted by the therapist.

Loosening the Italian grip on the side allows for the head support cushion to move backwards and forwards.

Loosening the star-wheel at the end of the horizontal bar allows for adjustment of the angle of the head support cushion.

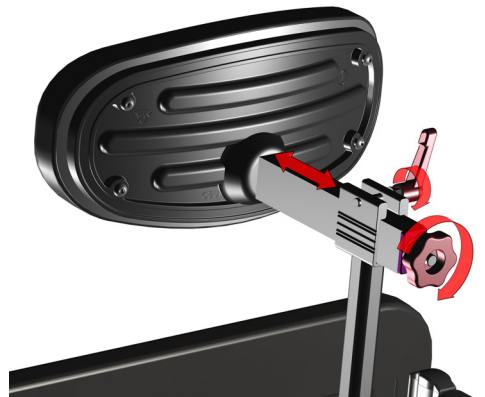

### 5.7.2 NETTI DYNAMIC HEAD SUPPORT ADJUSTMENTS

The **Netti V** can be equipped with a Netti dynamic head support: The head support follows the backward movement of the head when the head is pressed against it.

A small cylinder dampens the movement and brings the head back to normal position after extension.

#### **DEPTH ADJUSTMENT:**

- Unlock the two red levers, one on each side of the head support horizontal tube.
- Move the head support forwards or backwards to desired position.
- Fix the two levers firmly.

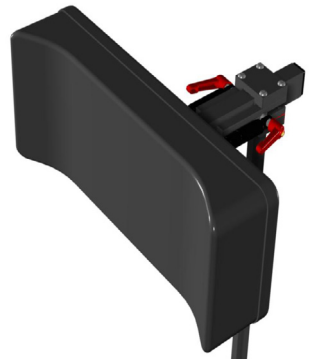

## 5.8 ARM SUPPORTS ADJUSTING

### 5.8.1 ARM SUPPORTS HEIGHT

Adjust the arm support height to fit the user. The height should give good underarm support without lifting the shoulder. There are 5 height positions available, with 15 mm distance between each.

- Unscrew and position the arm support in correct height for the user.

-  1 pc hex screw wrench

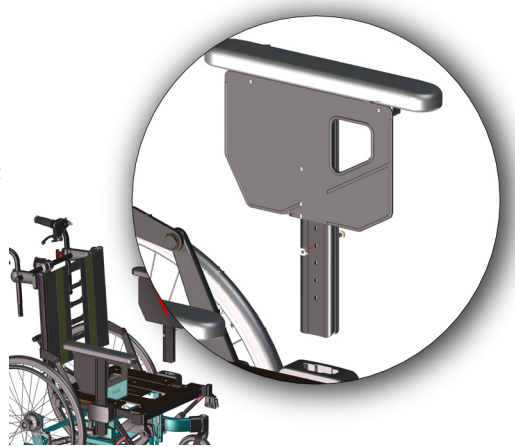

### 5.8.2 ARM SUPPORTS DEPTH

If the adjustments at the front of the arm support is not giving you enough support the arm pad can be moved forwards.

- Loosen and slide the arm pad to desired position.

-  1 pc screwdriver for M5 mm Phillips screw

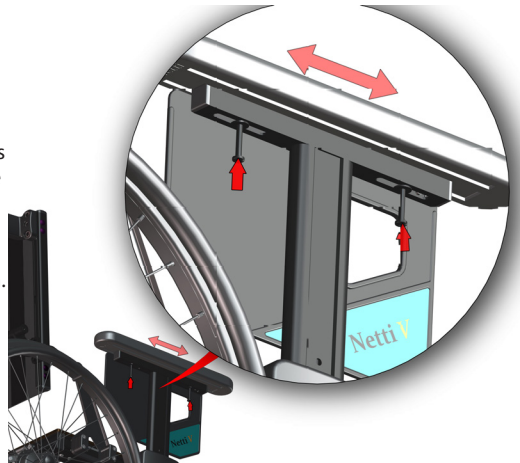

### ARM SUPPORTS POSITION

If the arm support vertical profile fits either too loose or too tight in the arm support bracket it can be adjusted to better fit.

- Remove the arm support covers.
- Tighten or loosen the 2 screws according to need.
- Test the fit by inserting the arm support.
- Mount the covers.

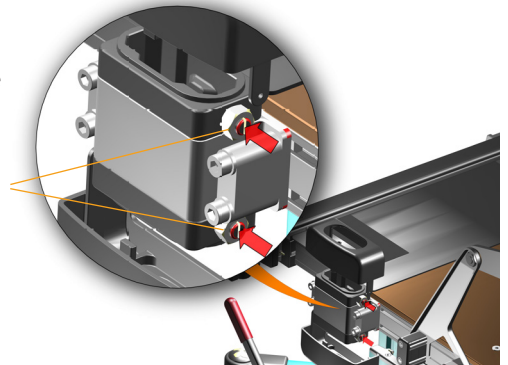

### 5.8.3 ARM SUPPORTS HANDLING

The arm support is inserted into the arm support bracket. It is removed by lifting it up and out of the bracket.

When the arm support is removed there is free space for side transfer.

With the arm supports removed there is good access to place sails etc behind the back of the user.

 Always lock the brakes when you plan for actions and remove the arm support.

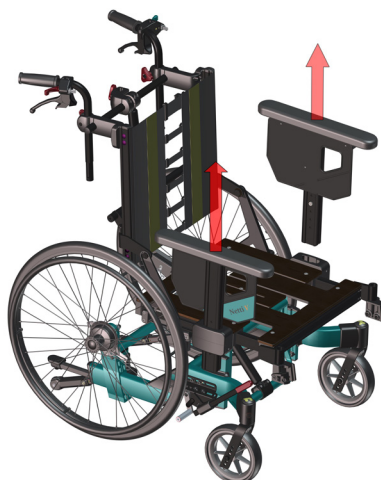

### 5.9 BELTS AND HARNESSSES

#### MOUNTING, POSITIONING AND ADJUSTMENTS OF PELVIC SUPPORTS AND SUPPORTIVE HARNESSSES

Netti V is prepared for mounting several different types of pelvic stabilizer and supportive harnesses, each type developed to give the user the best stabilization support depending on the conditions:

Available belts and harnesses:

- Pelvic stabilizer
- Upper body harnesses
- Ankle huggers
- Heal straps

#### PELVIC STABILIZER / BELTS

mounted to the seat plate, helps the user to keep his/her position on the seat even when he/she is sitting quite restless.

There are 3 alternatives for fixing pelvic stabilizers / belts:

- In the back bracket - a hole and mounting screws 95524
- In the seat frame side profile. M6 nuts are available for fixing belts, one in front and one behind the back bracket.
- On the pelvic support rail mounted to the seat plate - see next page.

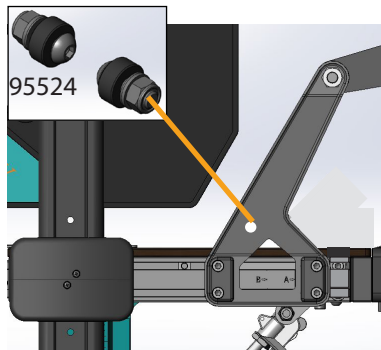

### HOW TO ADJUST THE PELVIC STABILIZER

The pelvic stabilizer is mounted on the belt fixing brackets on the pelvic support rail on the seating plate as shown on the illustration.

The pelvic position rail can be outwards adjusted to follow seat width adjustments.

- Position the pelvic stabilizer to a position where it crosses the upper thighs, Angle: 70- 90 degrees.
- Adjust the pelvic stabilizer / belt mounting point for the belt to be tightened.
- Remember to shorten the stabilizer beneath the last used hole to avoid any conflict with chair frame-

 A pelvic stabilization belt must always be used when using upper body harness.

Illustration may differ from product.



95521

### H-BELT RACK FOR UPPER BODY HARNESS

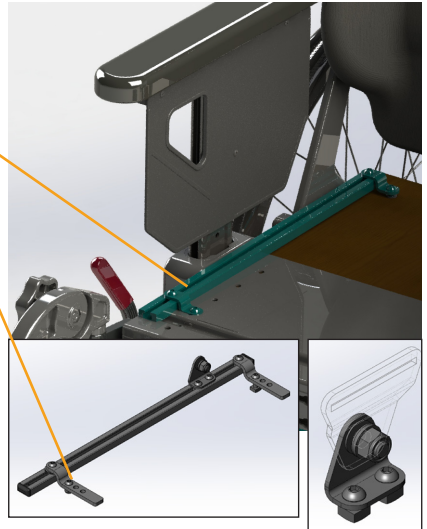
Upper body harness rail is mounted by separate brackets mounted to the crossbar where the push-handles are mounted.

See separate Mounting Description for upper body harnesses at: [www.bodypoint.com](http://www.bodypoint.com)

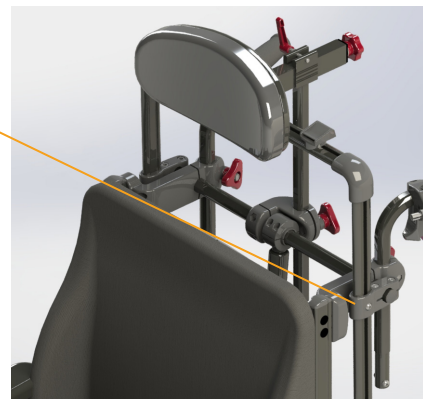





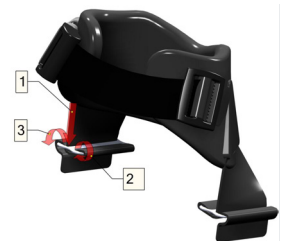

### ANKLE HUGGERS AND HEEL STRAPS

help to keep the feet on the foot board not letting them slide of during use.

The ankle huggers are mounted by threading them through the slots in the foot board on the leg support and fixing the belt on the underside of the foot plate, threading shown in the illustration - follow the numbers.





<b>BELTS AND HARNESSSES</b> for <b>Netti</b>	Description	Pictures
<b>BELTS / Stabilizers</b>		
Pelvic Stabilizer Evoflex M	Medium	
Pelvic Stabilizer Evoflex L	Large	
4-point belt padded M	Medium	
4-point belt padded L	Large	
<b>HARNESSSES</b>		
Chest support Stayflex w/o Zipper	Medium	
Chest support Stayflex w/o Zipper	Large	
Belt shoulder harness Pivotfit M	Medium unisex	
Belt shoulder harness Pivotfit L	Large unisex	
<b>LOWER EXTREMITIES</b>		
Calf support pad	Medium	
Calf support pad	Large	
Ankle-Huggers S	Small 170-200 mm	
Ankle-Huggers M	Medium 190-230 mm	
Ankle-Huggers L	Large 220-290 mm	
Ankle-Huggers XL	Extra large 280-330 mm	

For complete and updated overview, please see our homepage – product catalogue – [my-netti.com](http://my-netti.com)

## 5.10 LEG SUPPORTS

**Netti V** is as a standard delivered with Netti Universal leg supports. The chair can also be equipped with following alternative leg supports:

- 
- Angle adjustable leg support standard
- Dynamic leg supports
- Amputation leg support
- Grandis leg support

 **Netti V** allows for adjusting the leg support outwards. When adjusting more than 25 mm, a new leg support foot plate needs to be purchased to ensure that the gap between the foot plates will remain < 25 mm. Choose the correct size of foot board/leg support depending on the leg support mounted and the gap to cover.

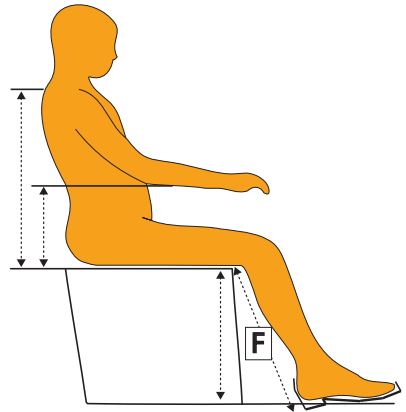

### 5.10.1 LEG SUPPORT HEIGHT AND LENGTH ADJUSTMENTS

Leg support adjustment takes place on 2 different locations. First adjustment is the foot plate height. The second adjusting the seat plate depth and the seating unit position in the frame. The goal is having the leg support knee joint and the user knee joint aligned in the same axis.

Measure the user's lower leg length F - 90 degrees bent knee - measure from underside thigh to the underside heel of normal used shoe.

The knee joint of the leg support may be hidden under the knee upholstery. Adjust the foot board height according to the lower leg length measured.

 Make sure there is enough free space under the foot-plates for the wheelchair to pass minor obstacles.

Slightly tilting the seating unit may help.

If not sufficient, the chair height must be adjusted as described in this instruction for use chapter 5.3

 **CORRECT SEAT DEPTH:**  
Adjust the seat plate and position as described in chapter 5.4.

- The foot plates are hinged, and can be angled in fixed positions.

## 5.10.2 UNIVERSAL LEG SUPPORTS

The Universal leg supports are swing-able, height adjustable and removable.  
They are adjusted to a fixed angle.

Heel straps prevent the feet from sliding from the foot plates.

### UNIVERSAL LEG SUPPORT MOUNTING INSTRUCTION:

- Fold the foot plates up.
- Hold the leg support on the top joint, and place it in the leg support bracket on the wheelchair in an outward turned angle as shown in the picture.
- Swing the leg support inwards and push slightly downwards until it goes into locked position.

### ANGLE ADJUSTMENT

- Loosen the star wheel on the outside of the leg support.
- Lift the lower part of the leg support to required angle.
- Tighten the star wheel.

### FOOT PLATE HEIGHT ADJUSTMENT:

The foot plates are step less height adjustable.

- Unfix the adjustment screw so that the adjustment bar moves freely.
- Slide the foot plate to required height,
- Tighten the screw.

 5 mm Allen key

### FOOT PLATE ANGLE ADJUSTMENT:

- Loosen the screw on the outside of the foot plate - see picture - with an Allen key.
- Tilt the foot plate to required angle and tighten the screw.

 6 mm Allen key

 Never stand on the foot plates due to the risk of tipping forward.

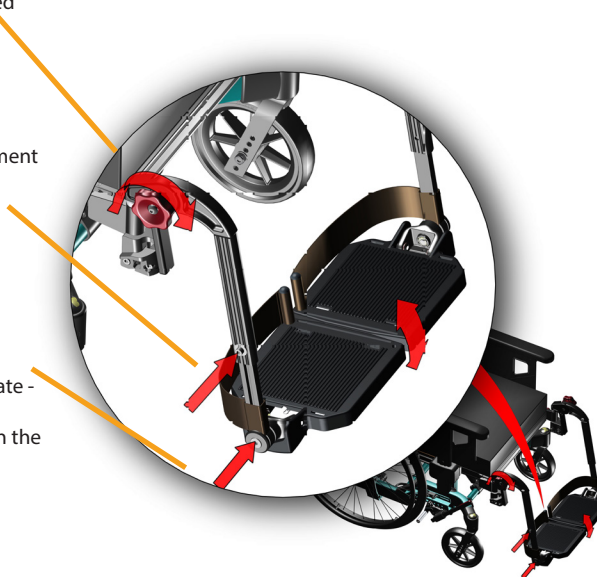

### 5.10.3 ANGLE ADJUSTABLE LEG SUPPORTS

The angle adjustable leg supports are swing-able, height adjustable and removable. They come with height- and depth adjustable calf supports. The foot plates are hinged, and can be angled in fixed positions.

The foot plates come with a lock connecting the 2 plates which makes the plates stronger. If locking is not wanted, the bolt can be removed by using an Allen key with no loss of functionality.

#### ANGLE ADJUSTABLE LEG SUPPORT MOUNTING INSTRUCTION:

- Fold the foot plates up.
- Hold the leg support on the top joint, and place it in the leg support bracket on the wheelchair in an outward turned angle as shown in the picture.
- Swing the leg support inwards and push slightly downwards until it goes into locked position.



#### ANGLE ADJUSTMENT

- Loosen the star wheel on the outside of the leg support.
- Lift the lower part of the leg support to required angle.
- Tighten the star wheel.

 Be aware of squeeze hazard between moving parts.

#### FOOT PLATE HEIGHT ADJUSTMENT:

The foot plates are step less height adjustable.

- Unfix the adjustment screw so that the adjustment bar moves freely.
- Slide the foot plate to required height,
- Tighten the screw.

 As an accessory a star knob or a lever handle can replace the screw.

#### FOOT PLATE ANGLE ADJUSTMENT:

- Loosen the screw on the outside of the foot plate - see picture - with an Allen key.
- Tilt the foot plate to required angle and tighten the screw.

 5 mm Allen key

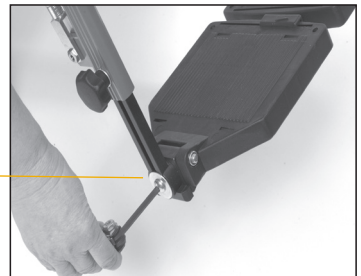



## LOCKING AND RELEASING THE FOOT PLATES

- To lock the foot plates, let the right foot plate fall over the bolt standing out from the left one, it clicks into lock.
- To release the foot plate pull the plastic lock between the foot plates and lift the right foot plate up.



 While making the adjustment, there must be no load on the foot plates.

 For outdoor use, there should be a clearance of 40-50 mm between the foot plate and the ground.

 Never stand on the foot plates due to the risk of tipping forwards.

## CALF SUPPORT ADJUSTMENTS

The calf supports are height and depth adjustable. The calf supports must be adjusted in a height and depth that prevents the feet from sliding down from the foot plate.

### HEIGHT ADJUSTMENT:

Loosen the nut **A** on the calf support bracket and slide it into required position before fixing the screw.

 **10 mm open end spanner**

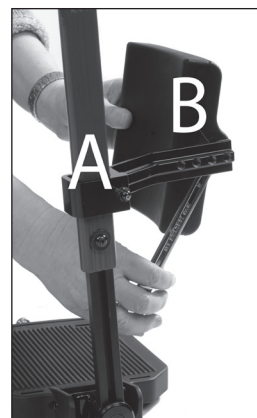

### DEPTH ADJUSTMENT:

Loosen the screw **B** between the calf support and bracket and reposition it to required position before fixing the screw.

 **13 mm Allen key**

 Never stand on the foot plates!

 Never lift the wheelchair by the leg supports.

### REMOVING THE LEG SUPPORT:

- If there is a foot plate lock, release the foot plate by pulling the red plastic lock between the foot plates.
- Lift the right foot plate up.
- Lift the leg support in the knee joint slightly up.
- Swing it out wards
- Lift it up.



## 5.10.4 NETTI DYNAMIC LEG

### SUPPORTS

#### NETTI DYNAMIC LEG SUPPORTS FEATURES

**Netti V** can be delivered with Netti Dynamic leg support

Netti Dynamic leg support is especial designed for users pushing with uneven force with their lower extremities providing an open kinetic chain. Unilateral extension of the hip (left or right part of the leg support goes down)

The gas springs works independent and allows for the leg supports to extended differently - tilting the foot-board sideways and also tilting it forwards. This multitude of possible flexible movements - gives the user freedom to perform voluntarily and involuntarily leg movements to very high degree. When the extension forces are reduced, the gas springs gently brings the feet and legs back to the original position.

The wear and tear on the wheelchair is substantially reduced since the forces applied, are absorbed by the gas springs and flexible system.

#### Functional overview

the Netti Dynamic leg supports allow controlled open Kinetic Chain (OKC) movements of the lower extremities of the user. Unlike static wheelchairs, the user's distal segments are supported but can move. This helps to gain control of the proximal segments especially when the user cannot inhibit movements due to their medical condition.

Netti Dynamic system leg support allows for dynamic:

- Plantar flexion of the feet (foot board pivots anteriorly)
- Unilateral extension of the hip (single leg support goes down)
- Knee extension: (leg supports move forwards).

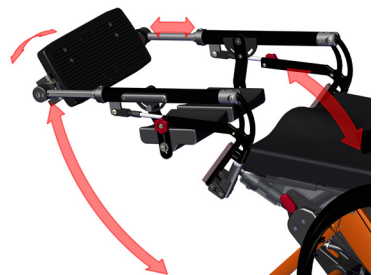
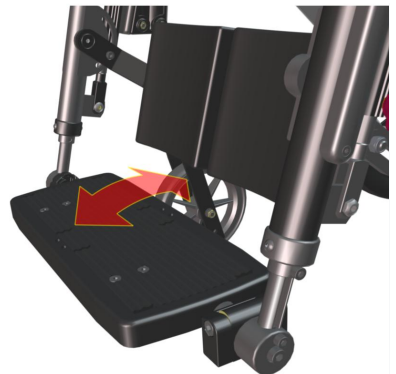

Netti Dynamic leg support is offered in 2 different lengths.

Netti Dynamic **short** leg support lengths suits persons with lower leg length from circa 350 mm up to approximately 450 mm (measured when knees are 90° flexed, from underneath the thigh to under the heel - inclusive normal shoes).

Netti Dynamic **normal** leg support lengths suits persons with lower leg length 450 - 550 mm lower legs.

## DYNAMIC LEG SUPPORT HEIGHT AND LENGTH ADJUSTMENTS

Leg support adjustment takes place in 2 directions. First adjustment is the foot board height and the second adjusting the seat plate depth. The aim is have the leg support knee joint and the user knee joint aligned in the same axis.

Measure the user's lower leg length F - 90 degrees bent knee - measure from underside thigh to the underside heel of normal used shoe.

The centre joint of the leg support is hidden under the knee-joint upholstery. The illustration with removed upholstery shows the leg support knee-joint centre which is to be at the same axis as the knee-joint of the user. Adjust the foot board height according to the lower leg length measured.

### Netti Dynamic:

#### Foot-board height adjustment

- Loosen the M6 screws holding the leg support length-profile on the outside with 5 mm Allen key.
- Adjust the foot-board to a height from top of front edge seat cushion to the foot-board equal to the lower leg length - F dimension.



1 pc 5 mm Allen key



Make sure there is enough free space under the foot-board for the wheelchair to pass minor obstacles. Slightly tilting the seating unit may help. If not sufficient, the chair height must be adjusted as described in this instruction for use chapter 5.4

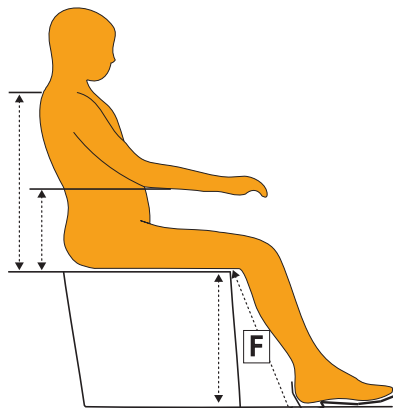

**i CORRECT SEAT DEPTH:**

Adjust the seat plate and position as described in chapter 5.4.4

Loosen the Velcro straps of the back support. Let the user sit onto the wheelchair - with cushions mounted. Check that the user is getting into the chair firmly. Adjust the back support by pulling the straps of the Velcro. The knees of the user should align with the joint of the leg support both in height and in depth. This will ensure that the user gets a good back support and pressure distribution under the thighs.

Extension pieces allow for adjustments for different leg lengths.

**5.10.5 DYNAMIC CALF SUPPORTS HEIGHT AND DEPTH ADJUSTMENTS**

With both leg supports in correct height, the calf supports must be adjusted:

**HEIGHT ADJUSTMENT:**

Loosen the two M6 screws with 5 mm Allen key - on the half-moon brackets - holding the calf pad arm. This allows the calf support-pad arm to move up and down. The calf supports should in addition to supporting the calf also help prevent the feet sliding backwards from the foot-board.

Choose a height covering the middle and lower part of the user's calf and tighten the screws. Twist the calf pads to an angle giving support for the leg when the foot support is angled. The calf pads can swing freely to follow the movements and adjust to the user's leg position.

 1 pc 5 mm Allen key

**DEPTH ADJUSTMENT:**

Loosen the M8 screw holding the calf pad on the calf pad arm with 2 pc 13 mm spanner and slide the calf pad in or out to desired depth - the calf pad barely touching the calf while the feet are standing on the middle of the foot board.

They should in addition to supporting the calf also help prevent the feet sliding backwards from the foot-board.

 2 pc 13 mm open end spanner

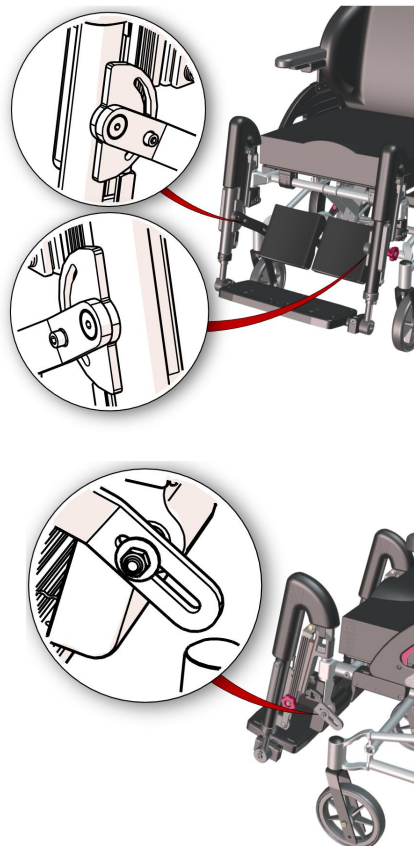

### 5.10.6 DYNAMIC FOOT-BOARD ANGLE ADJUSTMENT

Loosen the M8 screw on the left foot board with 6 mm Allen key. This allows the foot-board to rotate. Choose a foot-board angle to accommodate the user's foot angle. Fix the screws tightly so that the foot-board does not move.

 1 pc 6 mm Allen key

 The foot-board still allow for some rotation forward to flex when the user extends his/ her feet.

 Lubrication of the gliding length profiles with white Vaseline is important to ensure smooth function of the Netti Dynamic system leg supports.

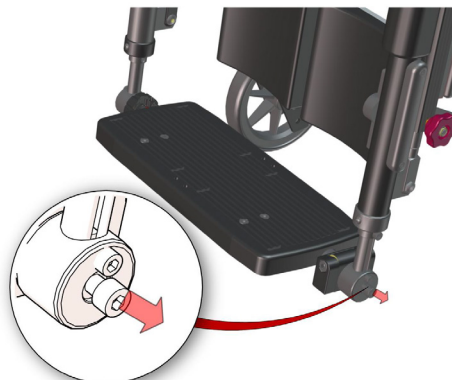

### 5.10.7 LOCKING THE NETTI DYNAMIC LEG SUPPORT

The red star knobs allow locking the dynamic elevation of the leg support plate.

For the dynamic use of the Netti Dynamic system (OK-C) this should be kept loose to allow for the knee joint to move (OK-C movement" for the knee joint). Locking the leg support may be required if sudden extension may lead the leg supports to hit persons or surrounding. It is also required if the wheelchair is being used as a seat in a car.

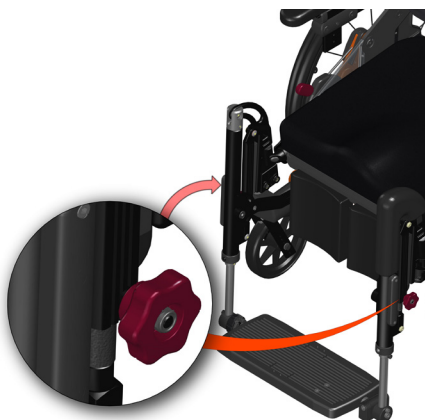

### 5.10.8 GRANDIS LEG SUPPORTS

-  The Grandis leg supports require Grandis leg support extension brackets.



The leg support Grandis is angle adjustable - from vertical to horizontal position.

- It is swing-able and removable.
- It is height adjustable and comes with height- and depth adjustable calf support.

As a standard the foot plates come with a lock connecting the 2 plates. This makes the plates stronger and reduces maintenance. If locking is not wanted, the bolt of the lock can be removed by using an Allen key.



#### MOUNTING OF THE GRANDIS LEG SUPPORT:

- Fold the foot plates up.
- Hold the leg support on the top joint, and place the vertical bolt in the leg support fixing bracket on the wheelchair, slightly turned outward.
- Swing the leg support inwards and push slightly downwards until it clicks into locked position.



## GRANDIS ANGLE ADJUSTMENT

To adjust the angle of the leg support simply release the red lever and lift or lower. The leg support will stay in the position where you lock the lever.

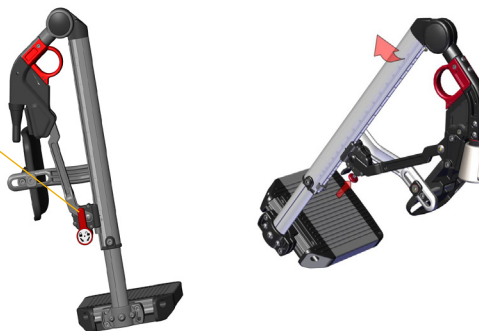

## GRANDIS FOOT PLATE HEIGHT ADJUSTMENT:

The foot plates are step-less height adjustable

- Loosen the adjustment screw for the adjustment bar to move freely.
- Slide the foot plate to required height, then tighten the screw well.

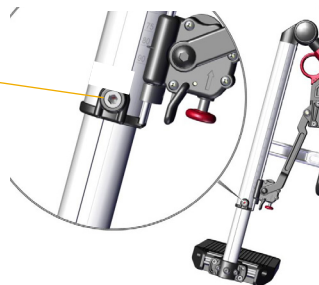

## GRANDIS FOOT PLATE ANGLE ADJUSTMENT:

- Unfix the 2 screws as shown below using an 5 mm Allen key.
- Adjust the foot plate to the required angle and tighten the screws.

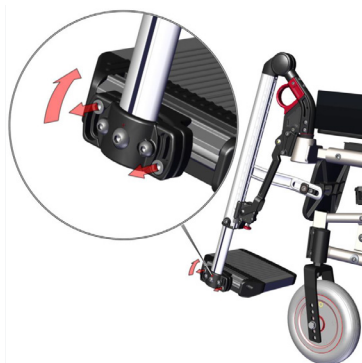

## GRANDIS FOOT PLATE DEPTH ADJUSTMENT:

- Unscrew the 2 screws completely as shown below, using an 5 mm Allen key.
- Pull out the foot plate and loosen the next 2 screw which has become visible.
- Slide the footplate forwards or backwards to desired depth before re-fixing all screws.

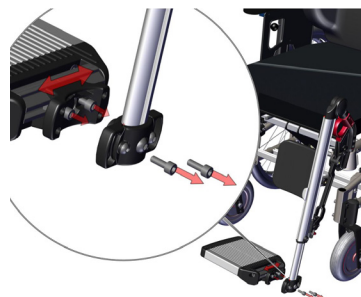

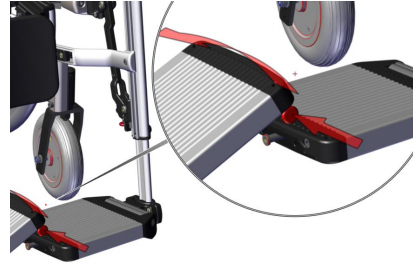

## LOCKING AND RELEASING THE FOOT PLATES

- The foot plates come with a lock connecting the 2 foot plates which makes the plates stronger.
- To lock the foot plates let the right foot plate fall cover the bolt standing out from the left one, it clicks into lock.
- To release the foot plate push the plastic knob under the right foot plate and lift the right foot plate up.



 While making the adjustment, there must be no load on the foot plates.

 For outdoor use, there should be a clearance of 40-50 mm between the foot plate and the ground.

 When adjusting leg support angle, be aware of squeeze hazard between moving parts.

## REMOVING THE GRANDIS LEG SUPPORT:

- Release the foot plate by pushing the red plastic knob under the right foot plate and lift the right foot plate up.
- Pull the red circular grip on top of the leg support and lift the support upwards while turning it slightly outwards.



## GRANDIS CALF SUPPORT ADJUSTMENTS

The calf support is height and depth adjustable and are to be adjusted in a height and depth that prevents the feet from sliding down from the foot plate.

For chair width 43-50cm where the high version of calf support is used, there are possibility for conflict with heel or seat plate when the leg support is adjusted for short leg length.

To adjust the **height**, loosen the screw on the calf support bracket and slide it into required position before fixing.

 Make sure to adjust the calf support that they do not conflict with seat plate or foot plates.

To adjust in **depth** of the calf pad, loosen the screw holding the calf support and slide it to required position before fixing the screw again.

 5 mm Allen key

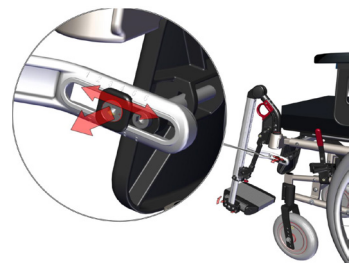

## 5.10.9 GRANDIS FIXED LEG SUPPORTS

-  The Grandis fixed leg supports require Grandis leg support extension brackets.

### MOUNTING LEG SUPPORT GRANDIS FIXED

- Fold the foot plates up.
- Hold the leg support in the vertical profile, and place the attachment bolt in the Grandis leg support pull out-piece in an outward angle.
- Swing the leg support inwards and push slightly downwards until it goes into locked position.

### TO REMOVE THE LEG SUPPORT

- Grab around the vertical profile and thereby your hand is lifting the red lock lever.
- Lift up and turn outward.

-  Grandis Fixed leg support can also be delivered with a foot plate - to be ordered separately

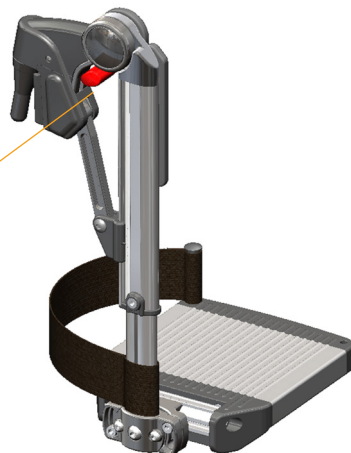

### GRANDIS FIXED LEG SUPPORT ADJUSTMENTS:

#### FIXED ANGLE ADJUSTMENT

- Loosen the screw on the outside of the vertical profile
- Swing the leg support to desired angle before tightening and fixing.

#### FOOT PLATE HEIGHT ADJUSTMENT:

- Loosen the screw on the outside of the vertical profile and
- Move the foot plate ( or foot board) to desired height before tightening and fixing.

#### FOOT PLATE ANGLE ADJUSTMENT:

- Loosen the 2 screws on the outside of the foot plate and rotate to desired angle before fixing.
- Details are also shown in chapter 5.10.2

-  5 mm Allen key

-  Never stand on the foot plates!

-  Never lift the wheelchair by the leg supports.

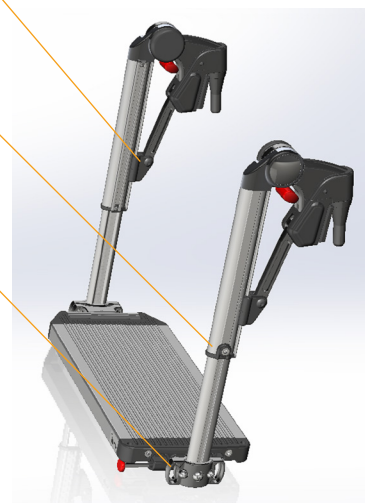

### 5.10.11 LEG SUPPORT MOUNTING AND REMOVAL

Mount the leg supports to the wheelchair. Ensure an open angle of the leg support when inserting: Position the bolt vertical into the frame hole turning it ca 30 degrees outward for it to enter easy. Turn it inward until it clicks into user position,.

 When mounting the leg supports, always check that there are no conflict between the front castors and the foot plates. Adjust the leg support angle if necessary.



### 5.10.12 FOOT PLATE LOCK

Leg supports can have foot-plates replaced by a foot-board. With both leg supports in place, the foot-board folds down into the lock on the right leg support.

The lock is closed by turning the outer ring 90 degrees forward!

 The foot-board lock **MUST** always be closed when the chair is occupied.

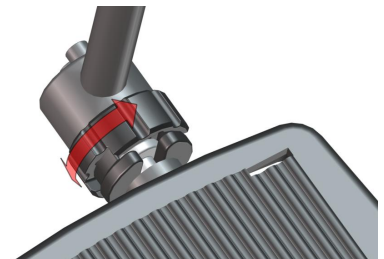
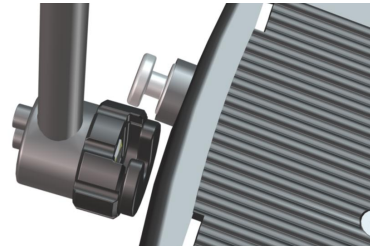

## 5.11 SIDE SUPPORTS

**Netti V** is prepared for fixing side support to the back tubes.

- Fold the chair-back forwards by releasing the pin.
- Insert square nuts into the back tube. At the top of the tube there is a wider space where the square nuts can fit into the groove.
- Fix the side support bracket to the back tube by screwing it to the square nuts you just inserted.
- Rise the back and adjust side support position suitable for the user.
- Adjust height, depth and inward position.

 5 mm Allen key

## 5.12 ABDUCTION BLOCK

**Netti V** seat plate is prepared for mounting abduction block to the front of it.

- Screw the abduction block bracket to the seat frame profile in the front. .
- Position it in the centre of the plate.

Adjust the height to fit the block tightly over the seat cushion.



 4 mm Allen key

## 5.13 PELVIC SIDE SUPPORT

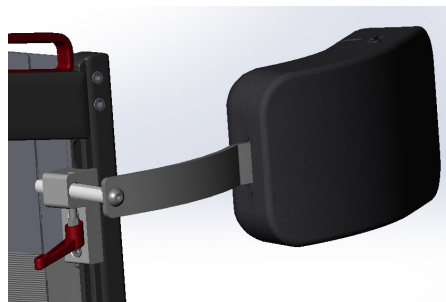
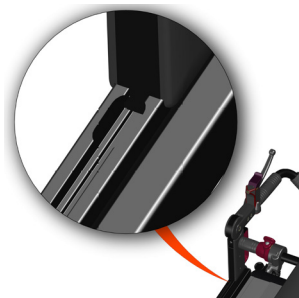
**Netti V** seat-plate is prepared for mounting pelvic side support rail to the top of it. The support slide forwards and backwards and can be adjusted inward to define a smaller seat width. It can also be used to give side support to the knee.



## 5.14 TABLE

-  **Netti V** can be fitted with a table or half table.
-  Please do a user assessment to determine if a table is suitable.
-  Never place any items on the table that may fall over and cause harm or can brake when the arm supports are not horizontal.



## 6. EVERYDAY USE OF NETTI V

A Netti V wheelchair is an advanced mobility aid. Please use some time to study this manual and become familiar with the wheelchair and all its possibilities.

Max user weight for Netti V is 135 kg.

After the wheelchair has been correctly adjusted to the user described in the previous chapters, you as an attendant need to learn how to take advantage of the tilt and recline features to give the user the most benefits of the chair.

### SEAT UNIT ANGLE - TILT

The seat unit angle is regulated with the tilt handle on the left push handle. The seat unit can be tilted from  $-3^{\circ}$  to  $+30^{\circ}$ .

 The tilt function is used for giving variation of the seating position for the user.

### BACKREST ANGLE - RECLINE

The backrest angle is regulated with the recline handle on the right push handle. The recline angle can be regulated from  $85^{\circ}$  -  $130^{\circ}$ .

### 6.1 KEY WORDS REGARDING TILT AND RECLINE OF COMFORT WHEELCHAIRS

Tilt and recline are the basic benefits of a comfort wheelchair. It allows for varying seating positions during the time in the wheelchair, for creating correct position, maintaining stability, stimulate ADL and protecting skin.

We have reviewed the clinical evidences regarding tilt and recline, and found there are several studies and best practice guidelines suggesting that the tilt and recline sequence is important to reduce shear and sliding:

When changing to a resting backwards leaning position: tilt first, then eventual recline.

When bringing the user upright from a resting position, the sequence should be reverse; first correct the recline angle then the tilt.

The most shear is induced when going upright from a recline and tilted position.



 The recline angle is to be adjusted by the therapist to accommodate the user's best seating position. Always returned to this angle when sitting in upright seating position

## 6.2 DECREASE THE POSSIBILITY OF SLIDING, SHEAR AND PRESSURE SORES:

By upright normal seating the muscle tone of the neck and back should be as low as possible for the user to prevent sliding. The therapist will identify the correct recline angle. A change of the recline angle from this position can disturb the correct body position, and cause an increased muscle tone in the neck.

**i** If the recline function is used during a transfer situation or other situations, it is very important that the recline angle is adjusted back to the correct, original position when the user is back to a normal seating position.

**i** Wrong use of recline can cause loss of position, an increased risk of sliding, an increased danger of shear strain and pressure sores.

## 6.3 OPERATING RECLINE: RECLINING THE CHAIR BACK

Pull the recline button on the right side of the push handle and recline the chair back. It will stop where you let loose.

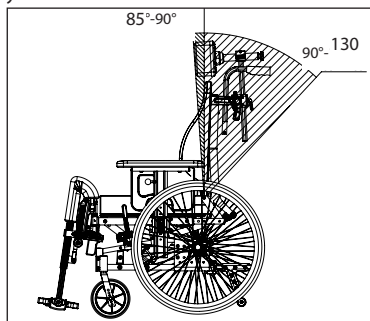

**MAKE SURE THAT THE USER IS SAFE WHEN TILT OR RECLINE ARE GOING TO BE ADJUSTED:**

The tilt and recline functions of all Netti wheelchair models are «one hand operations». This is a benefit for the user: The care giver is able to establish eye contact and communicate with the user when the tilt or recline function is going to be used. The user can feel more safe when tilted or reclined while eye contact is maintained between attendant and user.

## 6.4 OPERATING TILT: TILTING THE SEATING UNIT

Pull the tilt handle on the left side of the push handle and tilt the seating unit to desired position. The relative angle between the body upper and lower parts remain the same when the seating unit is tilted. Netti V can be forward tilted  $-3^\circ$  and backwards tilted  $+30^\circ$ . A rearwards tilted seat unit can create a position, with decreased risk of sliding an decreased danger of shear strain and pressure sores.

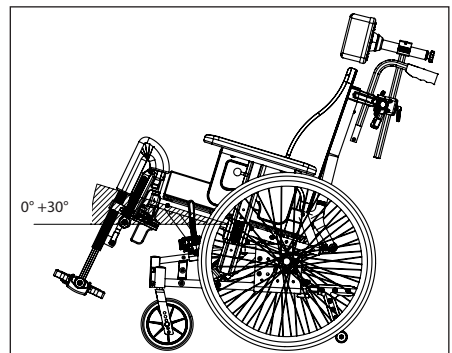

A forward tilted seat unit brings the user in a position where activities for instance by a table or by standing up from the wheelchair are supported.

**!** Never leave the user alone when the seat is tilted forwards. The user may slide forwards out of the chair.

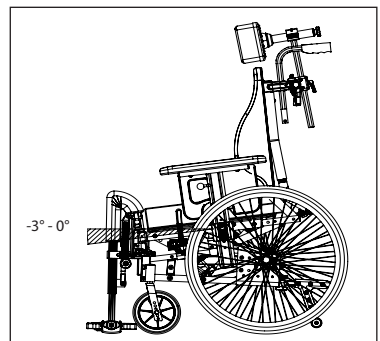

**i** Make sure the belts and harnesses are fixed in the best way for the user.

**i** A hip belt is of benefit for the user to keep the seating position and for the safety.

Upper body harnesses can be useful to connect the user to the back support. When using upper body harnesses the hip belt must always be locked first.

**i** Ankle huggers can be beneficial by connecting the feet to the foot plate, helping preventing them from sliding of.

## 6.5 PRACTICE THE USE OF THE NETTI V TILT AND RECLINE SYSTEM TOGETHER WITH THE USER

- Practice using the tilt function leaning the complete seating unit backwards and forward, experiencing and testing how the user react. Tilt is recommended to be used for varying seating positions, leaning backwards for resting - see previous page for details.
- Practice using the recline function by changing the back angle only. This is helpful when using a hoist to transfer the user in and out of the chair. Please return to correct recline angle after transfer.



## 6.6 TRANSFER TO AND FROM THE WHEELCHAIR

Techniques for transferring to/from the wheelchair should be practiced well with the persons involved.

Some important advices for preparation of the chair:

- The wheelchair should be placed as close as possible to the destination of the transfer.
- Make sure the brakes of the wheelchair are activated to prevent it rolling away.
- Remove the leg support
- Lift away the arm support on the side of the transfer.
- Eventually remove the head support



## 6.7 USING A PATIENT HOIST:

- Make sure the brakes of the wheelchair are activated to prevent it rolling away.
- Tilt the chair slightly backwards
- Remove the leg support
- Open the back support angle slightly while holding the user and adjusting the hoist behind the users back.
- Option: Remove the arm supports to get closer to the patient and / or remove the head support.
- Replace the components when the transfer is finished.

## 6.8 DAILY ATTENDANT HANDLING

### 6.8.1 PUSH HANDLES

The push handles are easily height adjusted at any time enabling good control over the wheelchair in the varying positions.

For safe manoeuvring the wheelchair and preventing injuries for the attendant, the push handles should be adjusted according to attendants arm height when the elbow is in an **90** degree angle

Open the starwheels holding the push handle and lift to desired height before fixing. Repeat on the other side. Tighten well.

For reduced stowing place:

- Rotated the push handle inwards by:
- Removing the screw on the bottom of the push-bow.
- Lift the bow up till you can rotate it inwards.
- Insert the screw again.

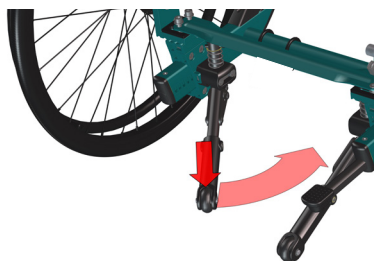
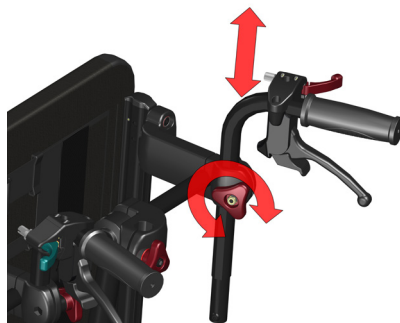

### 6.8.2 ANTI-TIPS

**Netti V** has foot operated swing-away anti-tips to ensure a safe and stable wheelchair. They are pre-mounted according to standard set up.

### 6.8.3 TRAMPING PEDAL

The tramping pedal is used for tipping the wheelchair backwards when passing obstacles.

- Step with one foot on the tramping pedal.
- Pull and slightly press the push handles downwards and at the same time
- Tip the wheelchair.



### 6.8.4 BRAKES

**Netti V** is equipped with drum brakes that are operated with the brake handles on the push handles plus user knee lever brakes in front of the main wheels.

The brake handles on the push handles can be used as running brakes like on a bicycle.



#### ATTENDANT BRAKES HAVE PARKING BRAKES

- To apply the brakes, pull the brake levers (1) evenly and smoothly towards the handles.
- To activate the drum brakes for parking, push the little lever (2) on the brake handle downwards while you hold the brake handle pulled.
- Next time you pull the brake lever the parking function is release.

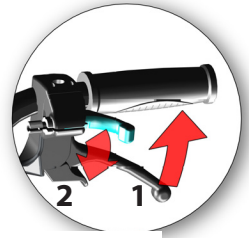

#### USER BRAKE IS PARKING BRAKE

Pull the red user brake handle backward to lock the brake one on each side of the chair.

-  Always use the parking brake when the wheelchair is left without attendant standing close. Lock the parking brakes on both sides.



#### 6.8.5 ARM SUPPORTS

**Netti V** is equipped with removable arm supports.

##### LOCKING · UNLOCKING

The arm supports are simply lifted out of the arm support bracket.

The height position screw keep the arm support at correct height every time.

Mounting the arm support:  
inserting the pole into the arm support bracket.



## 6.8.6 HEAD SUPPORT-MOUNTING

**Netti V** can be fitted with one of the Netti head supports. All Netti head supports will fit the chair.

### Head support adjustments:

The head support adjustment should be set by the therapist adjusting the wheelchair to the user. The height of the head support needs to be adjusted to fit directly behind the head giving support to the lower part of the skull.

The depth of the head support should be adjusted to barely touch the back of the user's head when sitting relaxed.

### HEAD SUPPORT MOUNTING AND REMOVAL:

The heads supports for **Netti V** are easily mounted and removed:

Open the starwheel **1**. The head supports is released and can be lifted up and removed.

To mount - insert the vertical head support pole into the head support bracket and tighten well.



**Netti V** can be equipped with Netti Dynamic head support:

The dynamic head support follows the backwards movement of the neck. This is beneficial both for users with involuntary movements and users nodding or banging the head.

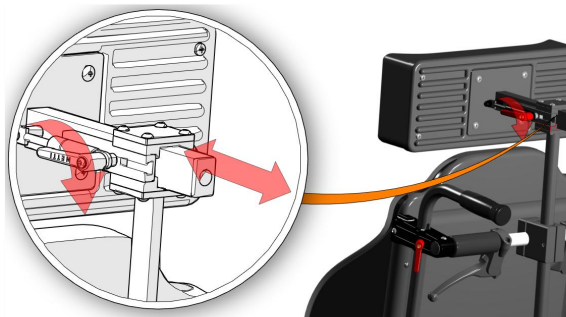

## 6.8.7 LEG SUPPORTS - MOUNTING

### Netti leg supports removal:

- Unlock the foot plate - if mounted -  
Pull the leg support slightly upwards.  
Swing it outwards before lifting and detaching it from the chair.

### Netti leg supports mounting:

Push the leg support fixing bolt vertical into the leg support fixing bracket on the wheelchair - keeping the leg support slightly turned outwards. The leg support will fall in place and turn into place itself.



### FOOT PLATE LOCK

Many of Netti leg supports have foot plates with lock. The lock connects the foot plates and help stabilize the foot plates.  
If a footplate lock is mounted it must be opened before the foot plates can fold up.

To open: push the red button sitting in the gap between the foot plates and fold up.  
When the foot plates fall down they will most likely fall into the lock by themselves. Please check.

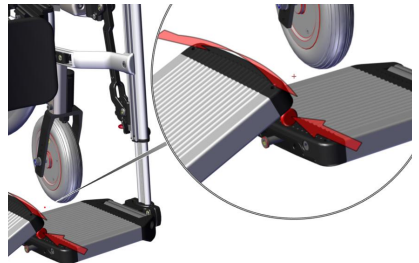

### 6.8.8 LEG SUPPORT FOOT BOARD

Netti Dynamic DUAL leg supports are equipped with a foot board. It is linked to the left leg support and folds down into a foot board lock in the right leg support:



#### FOOT BOARD LOCK

With both leg supports in place, let the foot board swing down and put the bolt into the lock, see pictures to the right. Rotate the outer ring to lock it.

-  Always lock the foot board when the user sits in the chair. Failing to lock may lead to damage to the leg supports and eventual also harm to the user.



### 6.8.9 LOCKING DYNAMIC LEG SUPPORTS

The Netti Dynamic Leg support angle can be locked by tightening the red wheel on the outside of the leg supports. See illustration:

This stops dynamic movements except for the limited rotation of the foot board.

-  Always lock the dynamic function of the leg supports when the chair is used as a seat in a car.

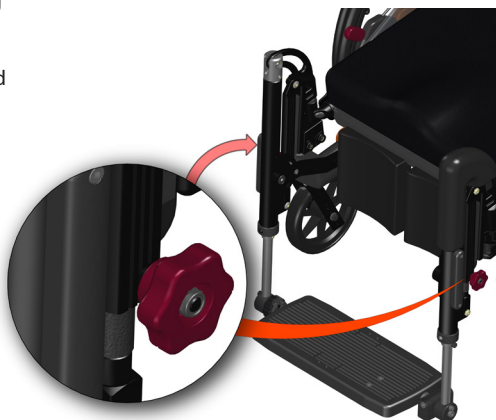

## 6.9 BELTS AND HARNESSSES

**Netti V** is prepared for mounting several different types of pelvic stabilizer and supportive harnesses, each type developed to give the user the best stabilization support depending on the conditions:

- Pelvic stabilizer
- Upper body harnesses
- Heel straps
- Ankle huggers

Use harnesses, pelvic stabilizers and ankle huggers / shoe shells to give the user needed stabilizing support.

 Always use the mounted belts, harnesses and ankle huggers to secure the user when sitting in the Netti V.



Max backwards tilt

**PELVIC STABILIZER**, mounted to the seat plate, helps the user to keep his position on the seat even during restlessness and involuntary movement.

### HOW TO ADJUST THE PELVIC STABILIZER

The pelvic stabilizer is mounted on the belt fixing brackets on the rail on the seating plate.

- Slide the pelvic stabilizer to a position where it crosses the upper thighs and angle 60- 70 degrees.
- Adjust the length of the pelvic stabilizer / belt a and mounting point so that the belt can be tightened.

 A pelvic stabilization belt must always be used when using upper body harness and always be locked before locking the harness.

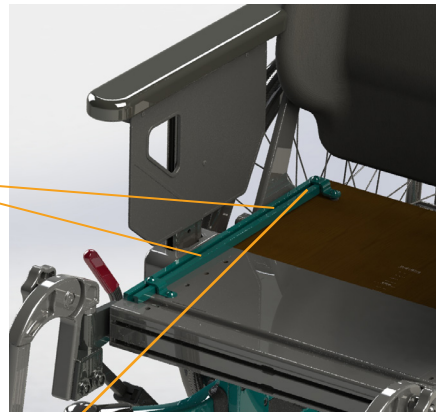

**THE UPPER HARNESSSES** are mounted with Quick-Locks to the harness rail behind the chair-back support. The Quick locks are easy to open and adjust at any time.

**THE LOWER HARNESSSES** are mounted at the rear on the rail on the seating plate.

### ANKLE HUGGERS AND HEEL STRAPS

are mounted to the foot board. They help to keep the feet on the foot board not letting them slide off the foot plates or foot board.



## 7. TRANSPORT

### 7.1 TRANSPORT IN CAR

Whenever possible, transfer to a car seat with vehicle safety belts when you are travelling with a car. Secure the wheelchair or store it in the cargo area of the car.



Netti V has been successfully crash tested in a forward facing orientation with both pelvic and shoulder belts, according to the requirements of ISO 7176-19 and is approved to be used as a seat in a vehicle.

Netti V is tested with a combined wheelchair and occupant restraint system W120/DISR from Unwin Safety Systems. For further information: BraunAbility Europe. <https://www.braunability.eu/wtors>

Always use approved wheelchair and occupant restraint system (ISO 10542) for fixing the wheelchair in the vehicle. Use a 4-point strap-type tiedowns to secure the wheelchair in the vehicle

The rating for the wheelchair's accommodation of vehicle anchored belt restraints is rated A = good.

#### REMOVE ACCESSORIES

Before using the Netti V as a seat in a car, be sure to remove and secure all auxiliary parts and accessories (e.g. trays and abduction block) that may fall off the chair in case of an accident and secure them safely elsewhere.

**Netti V** has been crash tested without any power assistant device etc. If, at a later point of time a power kit, stair climber etc. is mounted, you need to check if your power assistant device is crash tested and approved for wheelchairs being used as seat in a car. If not, the assistant device must be dismantled and secured elsewhere, when the wheelchair is used as a seat in a car.

 Netti V seat width 350-550 mm is approved for user weight up to 135 kg when used as a seat in a vehicle.

### SECURING THE WHEELCHAIR

 Raise the chair to an upright seat position with max 10 degree tilt and 10 degree recline.

For fixing the wheelchair in the vehicle only the designated securement points should be used.



The chair is marked with stickers showing the wheelchair securement points.

**In front:** Use hook or strap attachment.



#### **In the rear:**

Hook on strap or a hook/carbine hook into the car fixing loops on the frame.

The angle of the straps should be close to 45°



## SECURING THE USER

 Always use 3-point car occupant restraint belts.





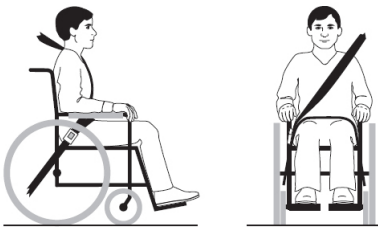
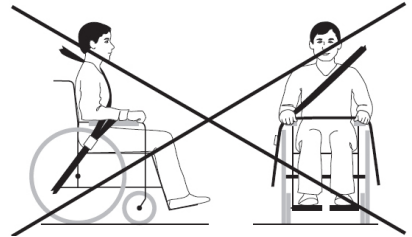

 Always use both pelvic and shoulder restraints to reduce the possibility of head and chest impact with vehicle components. Watch out that the belt is not twisted and the release buckle will not get in contact with the chair in case of a crash.

Make sure the car safety pelvic-belt lay tightly across or in front of the pelvis - the angle between pelvic belt and the horizontal between 30 - 75 degree, the steeper angle the better. The shoulder belt must lay close to the body of the user and not across arm supports, wheels etc. See illustration

 The shoulder belt must not lay across arm supports, wheels etc. See illustration



 The corrective harnesses used in the wheelchair are not safety belts.

-  If the user is 1.85 m or longer, the back extension kit and a 500 mm vertical bar for the head support must be mounted when Netti V is used as a seat in a car.
-  If a Netti head support is mounted correctly it is very stable but does not replace the need for an external neck support mounted in the car.
-  Always use Netti or other tested foam cushions when Netti V wheelchair is used as seat in a car.
-  Never use the wheelchair as a seat in a car if it has been involved in an accident with impact, before the chair has been inspected and approved for this by the manufacturer's representative.
-  Netti V with seat width 500 mm and more, may exceed the max width of 700 mm specified in PRM-TSI and have influence on the possibility for train transport.
-  Alterations or substitutions should not be made to the wheelchair securement points or to structural and frame parts or components without consulting the wheelchair manufacturer.
-  The wheelchair mass ex cushions is between 33 and 36 kg depending on wheelchair size and configuration.

## 7.2 FOLDING FOR TRANSPORT

When the wheelchair is unoccupied, fold it as described below. Put the wheelchair in the trunk or the back seat. When placed in the back seat, secure the frame using safety belts.

- Remove the head support (chap. 6.8.5)
- Swing push-handles inwards (chap. 6.8.1)
- Revolve the arm supports up (chap. 6.8.4)
- Remove leg supports (chap. 6.8.6)
- Remove backrest cushion
- Release backrest and fold it forwards (chap. 5.5)
- Remove main wheel (chap. 5.3)
- Remove front castor (chap. 5.3.3)

## 7.3 TRANSPORT IN AIR-PLANE

**Netti V** wheelchair may be transported in air-plane without any restrictions.

**Netti V** wheelchairs are equipped with 2 gas cylinders. These are however not classified as dangerous goods.

**Netti V** is configured with tilt and recline functions which are activated with gas spring(s).

Contrary to general dangerous goods instruction UN3164, the IATA-DGR (special regulation A114) rules that the goods that contain gas and are determined to function as shock absorbers (including energy-absorbing devices or pneumatic springs) are NOT subject to the transport instructions i.e. they are indemnified from the following requirements:

- a) each article has a gas volume which does not exceed 1,6 l and a charge pressure not exceeding 250 bar, where the product of the capacity expressed in litres and charge pressure expressed in bars does not exceed 80.
- b) Each article has a minimum burst pressure of 4 times the charge pressure at +20 degree Celsius for products not exceeding 0,5 l gas space capacity.
- c) Each article is made of material that will not fragment.
- d) Each article was manufactured in accordance to quality standard which is approved by the responsible national authority.
- e) It is proven and shown that the article relieves its pressure by means of a fire degradable seal or other pressure relief device such that the article will not fragment and the article does not rocket.

## 7.4 TRAVELLING ON PUBLIC TRANSPORT

The wheelchair should be put in a special area for wheelchairs.

The wheelchair should face opposite the direction of travel. The back of the wheelchair must be located against a fixed object such as a row of seats or a partition. Make sure the user can easily reach any hand rails or handles. Use belts and harnesses in the chair to hold the user. Use safety belts if available to secure the user in the vehicle.













## 8. MANOEUVRING

### 8.1 GENERAL TECHNIQUES

#### SITTING IN YOUR CHAIR

Once on your chair, make sure that you are comfortably positioned and that the leg supports and arm supports have been adjusted to suit your needs and that you have good back support.

#### GUIDELINES FOR USE

-  Always drive carefully. Make sure your seating position is tilted and reclined in a way that you do have the overview when driving.
  -  **BALANCE**  
The weight load and balance of the chair influences the manoeuvring ability of the wheelchair. The weight, size and sitting position of the user are also influencing factors. The size and position of the wheels will influence the driving performance. The more weight placed over the main wheels, the easier it is to manoeuvre. If heavy weight is placed over the front castors, the chair will be heavy to manoeuvre.
  -  Avoid carrying bags on the push handles, it may make the chair unstable.
  -  The large available tilt and recline positions of the chair influences the manoeuvrability of the wheelchair. When large tilted/reclined position is used, the chair is not meant to be driven long distances. The attendant can drive the wheelchair with large tilted/reclined position for shorter distances like transferring from room to room.
  -  **RIGIDITY**  
The large available tilt and recline movements have influence on the rigidity of the wheelchair. The choice of main wheels also influences the rigidity. 16" wheels are more rigid than 24" wheels.
  -  **PASSING OBSTACLES**  
The anti-tippers may get in conflict with steps and obstacles when passing. Swing the anti-tippers away when passing an obstacle.
  -  **STEP APPROACH:**  
Always approach a step in slow motion preventing the front castors to hit the step with force. The user could fall out of the chair by the impact. The front castors could brake.
  -  **DRIVING FORWARD DOWN STEPS/ SIDEWALKS**  
Be cautious that you do not drive down steps higher than 30 mm. The leg supports may hit the ground first. Thereby you might lose the control and the leg supports may brake.
  -  **PARKING:**  
Increase the underneath support of the wheelchair by moving the chair about 100 mm backwards making the front castors turn forward.
  -  **DRIVING ON SOFT, ROUGH OR SLIPPERY GROUND**  
can make safe manoeuvring more difficult as the wheels may lose traction and it is difficult to control the wheelchair.
  -  **Leaving the user unattended:**  
If the user is left alone in the wheelchair, always lock the brakes and secure that the anti-tips are turned down.
  -  **EMERGENCY ESCAPE ROUTES:**  
**Netti V** with seat width 500 mm and more, has an overall width exceeding 700 mm and may have difficulties passing emergency escape routes.
- Please be aware that wider wheelchairs have bigger turning radius and reduced manoeuvrability in vehicles. Smaller wheelchairs generally provide greater ease of vehicle access and manoeuvrability to a reach forward facing position.

## 8.2 DRIVING TECHNIQUES - STEP UP -



- i** The anti-tippers can be folded away when passing steps and obstacles. Be careful when you have to pass heights.

### **Companions, drive up a step forwards:**

- Angle the wheelchair backwards on the drive wheels by stepping on the tipper pedal before pulling on the push-handles.
- Push forward till the front castors stand on the step and continue to push while you also lift holding on to the push-handles.

### **Fold down the anti-tippers**

### **Users, drive up a step backwards:**

This technique is only useful if the step is low. It also depends on the clearance between the foot plates and the ground.

- Drive the chair backwards towards the step.
- Make a firm grip on the push rims and move the body forward while pulling.

### **Fold down the anti-tippers**

### **Companions, drive up a step backwards:**

- Pull the chair backwards next to the step.
- Angle the wheelchair backwards, moving the front castors slightly up in the air.
- Pull the wheelchair up by the push handles onto the step and go backwards long enough to put down the front castors on the step.

### **Fold down the anti-tippers**

## 8.3 DRIVING TECHNIQUES - STEP DOWN

- i** The anti-tippers can be folded away when passing steps and obstacles. Be very careful when you have to pass small heights.

Companions, drive down a step forwards:

- Fold the push-bow down.
- Angle the wheelchair backwards, moving the front castors slightly up in the air.
- Drive carefully down the step and angle the wheelchair forward putting the front castors back on the ground.

### **Fold down the anti-tippers**



### **Companions, drive down a step backwards:**

- Move the wheelchair backwards to the step.
- Drive carefully down the step and move the wheelchair backwards on the main wheel until the front castors have come away from the step.
- Put the front castors down on the ground.

### **Fold down the anti-tippers**

## 8.4 DRIVING TECHNIQUES - SLOPE

Important advise for driving down and up hill avoiding the risk of tipping.

-  Avoid turning the wheelchair in the middle of a slope.
-  Always drive as straight as possible.
-  It is better to ask for assistance than taking risks.

### **Driving uphill:**

Move the upper part of the body forwards in order to maintain the balance of the chair.

**Make sure the anti-tippers are folded down and active**

### **Driving downhill:**





Move the upper part of the body backwards to maintain balance of the chair.

Control the speed of the chair by clutching the push rims. Do not use the brakes.

**Make sure the anti-tippers are folded down and active**



## 8.5 DRIVING TECHNIQUES - UP AND DOWN STAIRS

-  Due to the weight load - with wheelchair and user, we do not recommend driving a Netti V wheelchair up or down stairs. The strain on assistants will be more than the manual handling regulation and the ergonomic assessment max load. The risk for loosing control during stair passing can lead to danger for both wheelchair user and assistants.
-  Use ramps and elevators when moving the user to higher or lower floor.
-  Never use escalators, even if assisted by a companion.
-  Do not lift the wheelchair holding onto the push-bow, leg-, arm- or head supports.

## 8.6 TRANSFER

Techniques for transferring to/from the wheelchair should be practiced well with the persons involved. Here, we give some important advices for preparation of the chair:



**With or without companion - sideways.**

**Before transfer:**

- The wheelchair should be placed as close as possible to the destination of the transfer.
- Pull the wheelchair backwards 50-100 mm in order to make the front castors turn forward.
- Lock the brakes.
- Remove leg support and swing up the arm support on the side of the transfer.

**With or without companion – forwards.**

**Before transfer:**

- The wheelchair should be placed as close as possible to the destination of the transfer.
- Pull the wheelchair backwards 50-100 mm in order to make the front castors turn forward.
- Lock the brakes.
- Tilt chair forward.

**Using a lift / hoist:**

**Before transfer to chair:**

- Tilt the chair slightly backwards
- Remove the head support
- Remove the leg supports
- Open the back rest angle slightly
- Replace the components when transfer is finished.



Never stand on the foot plates due to the risk of tipping the chair forwards.

## 8.7 POINT OF BALANCE

Adjust the point of balance by adjusting to correct seat depth for the user. This will move his/ hers centre of gravity and balance the wheelchair. In addition one can consider to change the position of the main wheel in the main wheel bracket.

- Move the main wheel hub and the main wheel. (Chap. 5.3.1)
- Adjust the drum brakes. (Chap. 5.3.6)
- Check that the main wheel and quick-release are locked properly. (Chap 5.3)



**2 pc 24 mm open-end spanner**



**5 mm Allen key**

The Netti V main wheel bracket allows for changing wheel position and thereby changing the seat height. If required frame extenders bracket can be mounted to move the main wheel 60 mm backwards.





The point of balance can also be changed by adjusting the seat angle and/or angle of backrest.

## 8.8 LIFTING THE WHEELCHAIR

The unfolded wheelchair without user should be lifted from 2 persons holding on to the frame and push bar only.

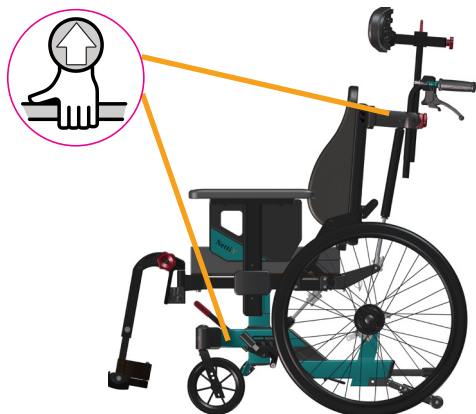
It is marked with a symbol where it should be lifted.



 Never lift the wheelchair when holding on to the leg-, arm- or head supports. They may detach and the wheelchair may fall and get damaged.

 Never lift the wheelchair with a user in it.

## 8.9 PUSH RIM

Netti wheelchairs are delivered with aluminium push rims as standard. The material and distance to the main wheel influences the ability of the user to grip. Contact your dealer to get information about push rims that fit your chair.

 Alternative push rims may give better grip, but the friction may increase. When using the hands to stop the chair, the risk for burning of the hands increases.

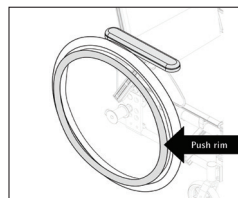

 A squeezing and trapping hazard of the fingers may occur when passing through narrow passages and if the fingers come between the spokes. To avoid this risk, we recommend spoke protectors as accessory.

 If you want/need to change push rims or increase/decrease the distance between the push rims and the wheel, please contact your dealer.

# 9. MAINTENANCE

## 9.1 MAINTENANCE INSTRUCTIONS

**i** You as a user of the wheelchair (and your attendants and family) are responsible for the everyday maintenance of the chair. Clean it regularly. Do the maintenance to ensure safe and long time reliable functions and hygienic appearance.

Frequency	Weekly	Monthly
Check defects / damages e.g. breakage / missing parts	X	
Washing of wheelchair		X
Washing of cushions		X
Check anti tip function		X
Check brake adjustment		X
Check tyre wear		X
Oiling of bearings with bicycle oil		x
Grease vertical leg support profiles with white Vaseline	X	

## 9.2 CLEANING AND WASHING

1. Remove cushions before washing the wheelchair.
2. Clean the frame using water and a rag.
3. We recommend using soft soap.
4. Rinse the wheelchair well using clean water to remove all the soap.
5. Use methylated spirit to remove any dirt left.
6. Clean cushions and covers according to instructions printed on cushions.

## NETTI CUSHION CLEANING PROCEDURES

CORE	
<b>Washing</b>	Hand wash 40° C
<b>Disinfection</b>	Virkon S
<b>Drying</b>	Squeeze
	Air dry standing edgewise
OUTER COVER	
<b>Washing</b>	Machine wash 70° C
<b>Drying</b>	Tumble dry max. 80° C

## DISINFECTION OF THE WHEELCHAIR

Remove cushions.  
 See separate washing instruction above:  
 Wipe disinfection: use a soft rag wetted with Hydrogen peroxide or technical alcohol (isopropanol) and wipe the whole chair clean.  
 Hydrogen peroxide recommended:  
 NU-CIDEX "Johnsen and Johnsen".

**i** Check / re-adjust screws and nuts at regular intervals.

**i** Sand and sea water (salt used for gritting in the winter) can damage the bearings of the front castors and main wheels. Clean the wheelchair thoroughly after use.

\* As a rule of thumb, use oil on movable parts and all bearings. Alu Rehab recommends use of ordinary bicycle oil.

### 9.3 LONG TERM STORING

If the wheelchair is to be stored for longer time (longer than 4 months) no special actions are needed. We recommend that the chair is cleaned before storing. Before it being used again, complete the above maintenance instructions.

#### SPARE PARTS

The Netti chairs are built of modules. Alu Rehab carries stock of all parts and is ready to supply these on short notice. Necessary instructions for mounting will follow the parts.

Parts to be handled by user are defined in spare part catalogues that can be downloaded at **my-netti.com**.

These parts can, if needed, also be removed and sent to manufacturer / distributor upon request.



Parts related to wheelchair frame construction must be handled by manufacturer or authorized service facility.



If defects or damages occur, please contact your dealer.





Original paint for repair of scratched, can be ordered from Alu Rehab.

# 10. TROUBLESHOOTING

Symptom	Reason / Action	Reference in manual
<b>The wheelchair is going askew</b>	<ul style="list-style-type: none"> <li>The angle of the bearing house might not be 90°.</li> <li>Check that the front castors are fitted in the same height.</li> <li>The main wheel hubs might be incorrectly mounted.</li> <li>One of the brakes might be too tight.</li> <li>The user are sitting very askew in the chair</li> <li>The user might be stronger on one side than the other.</li> </ul>	<p><b>5.3.2</b></p> <p><b>5.3.3</b></p> <p><b>5.3.4</b></p> <p><b>5.3.5</b></p>
<b>The wheelchair is heavy to manoeuvre</b>	<ul style="list-style-type: none"> <li>The main wheel hubs might be incorrectly mounted.</li> <li>Clean the front castors and forks for dirt.</li> <li>Too much weight over the front castors. (Adjust the point of balance by moving the seating unit backwards).</li> </ul>	<p><b>5.3.2</b></p> <p><b>5.3.3</b></p> <p><b>5.4.4</b></p>
<b>The wheelchair is hard to turn</b>	<ul style="list-style-type: none"> <li>Control that the front castors are not fixed too tight.</li> <li>Too much weight over the front castors. (Adjust the point of balance by moving the seating unit backwards).</li> </ul>	<p><b>5.3.3</b></p> <p><b>5.3.4</b></p> <p><b>5.4.4</b></p>
<b>The front castors are wobbling</b>	<ul style="list-style-type: none"> <li>The front castors are not fixed properly.</li> <li>Check that the front forks are fitted in the same height.</li> <li>The angle of the bearing house might not be 90°.</li> <li>Too much weight over the front castors. (Adjust the point of balance by moving the seating unit backwards).</li> </ul>	<p><b>5.3.2</b></p> <p><b>5.3.3</b></p> <p><b>5.3.4</b></p> <p><b>5.4.4</b></p>
<b>The main wheels are difficult to take off and put on</b>	<ul style="list-style-type: none"> <li>Clean and grease the quick release.</li> <li>Adjust the length of the hub bushing.</li> </ul>	<b>5.3.6</b>
<b>The brakes are not functioning well</b>	<ul style="list-style-type: none"> <li>Adjust the drum brake.</li> </ul>	<b>5.3.7</b>
<b>The wheelchair feels "shaky"</b>	<ul style="list-style-type: none"> <li>Check screws and adjustment points in general.</li> </ul>	

 Please contact your dealer for information about authorized service facilities that can give support if solution is not reached in this form.

 When in need of spare parts, please contact your dealer.

 When making changes affecting frame construction, contact dealer / manufacturer for confirmation.

# 11. TESTS & WARRANTY

## 11.1 TESTS

**Netti V** is tested and have been approved for both indoors and outdoors use. The chair is CE marked.

MAXIMUM USER WEIGHT:

135 kg for **Netti V**  
with seat width 350-550 mm

It is tested by accredited German test laboratory according to EN 12183

**Netti V** is crash tested at TASS Netherlands and evaluated by accredited German test laboratory according to ISO 7176-19. It is approved for being used as a seat in a vehicle.





Maximum user weight when used as seating a car: 135 kg

Netti seating system is tested for fire resistance according to: EN 1021-2.

## 11.2 WARRANTY

Alu Rehab is providing you with a 5-year warranty on all frame components and on the cross-tube assembly. There is a 2-year warranty on all other Netti labelled components except batteries. For batteries a 6 month warranty is provided.

 Alu Rehab is not responsible for any damage resulting from inappropriate or unprofessional installation and / or repairs, neglect, wear, from changes in wheelchair assemblies or instructions not approved by Alu Rehab or by use of spare parts delivered or produced by third parties. In such cases, this warranty shall be considered null and void.

 This warranty is only valid when the user use, maintain and handle the wheelchairs as described in this instruction for use.

## 11.3 CLAIM

If a product has developed a fault during the warranty period as result of a defect in design or manufacturing, you may forward a warranty claim.

- Claims are to be forwarded as soon as a defect is discovered and not later than 2 weeks after the defect is discovered.
- Claims are to be addressed to the sales agent of the wheelchair. Please note that sales documentation has to be filled in and signed correctly with serial number and eventual NeC number in order to document time and place of the purchase of the wheelchair.
- The sales agent and Alu Rehab are to decide whether a defect is covered by this warranty. The claimer will be informed about the decision as soon as possible.
- If the claim is accepted, the sales agent and Alu Rehab representative are to decide if the product will be repaired, replaced or if the customer is entitled to a reduced price.
- If a warranty claim is judged to be invalid - after careful inspection of the defect (defect due to wrong use and/ or lack of required maintenance) you are free to decide if you want to have the product repaired (if possible) at your expense, or if you want to purchase a new product.



Normal wear, incorrect use or incorrect handling is not a reason for claims.

## 11.4 NETTI CUSTOMIZED / INDIVIDUAL ADAPTATIONS

Netti Customized / individual adaptations are defined as all adjustments that are not included in this manual. Individual adaptations made by Alu Rehab are labelled with a unique NeC number for identification.

Wheelchairs that are especially adjusted / adapted by the customer cannot keep the CE mark given by Alu Rehab A.S Norway. If the adjustments are performed by other than Alu Rehabs approved dealers, the warranty given by Alu Rehab A.S Norway will not be valid.

If you have any uncertainty about special fitting and adaptations, please contact Alu Rehab A.S.



If you have different needs than what our standard wheelchair program can cover, please contact customer service for eventually special adjustments or Netti Customized solutions.

## 11.5 COMBINATIONS WITH OTHER PRODUCTS

Combinations of Netti and other products not manufactured by Alu Rehab A.S: Generally in these cases, the CE mark of all the products involved will not be valid. However, Alu Rehab A.S has made combination agreements with some manufacturers about some combinations. By these combinations the CE mark and warranties are valid.



For further information, please contact your dealer or Alu Rehab A.S Norway directly.

## PRODUCT RESPONSIBILITY

**Netti V** with different configurations of Netti equipment has been tested /risk evaluated by Alu Rehab.

Any alterations or substitutions must not be made to the wheelchair securement points or to structural and frame parts without consulting the wheelchair manufacturer Alu Rehab.

Substitutions or alterations of components from third part suppliers to Netti V requires the risk evaluation and acceptance of the product responsibility and safety for use of the wheelchair from the manufacturer that is performing the substitution or alteration.

## 11.6 SERVICE AND REPAIR

Information about service and repair services in your area, please contact your local dealer.



A unique identification number / serial number is to be found on the crossbar on the wheel frame on left side of the chair.



A spare part catalogue for the wheelchair can be obtained through your local dealer or downloaded at [my-netti.com](http://my-netti.com)



A refurbishment manual for the wheelchair can be obtained through your local dealer or downloaded at [my-netti.com](http://my-netti.com)



Information on product safety notices and product recalls are available at [my-netti.com](http://my-netti.com)



A recycling manual for the wheelchair can be obtained through your local dealer or downloaded at [my-netti.com](http://my-netti.com)



Any serious incident that has occurred in relation to the device should be reported to the manufacturer and the competent authority of the Member State in which the user and/or patient is established.

## 12. MEASUREMENTS & WEIGHT

### Netti V

Size - SW*	Seat depth **	Back height *** (Extender)	Total width****	Weight - ex cushions
350-400 mm	375 - 550 mm	515 (613) mm	590 mm	36.3 kg
400-450 mm	375 - 550 mm	515 (613) mm	640 mm	37.3 kg
450-500 mm	375 - 550 mm	515 (613) mm	690 mm	38.3 kg
500-550 mm	375 - 550 mm	515 (613) mm	740 mm	39.3 kg

\* SW - Seat Width: Dimension between arm supports.

\*\* Dimension from front edge of the seat plate to the chairback pole – without cushion.  
By correct placed UNO back cushion ca. 30 mm must be subtracted from this dimension.

\*\*\* Dimension from seat plate to top of the back.

\*\*\*\* Minimal total width = SW + 210 mm with 24" wheels, SW + 195 mm with 16" wheels



Weight include main wheels, front castors, leg supports and arm supports.  
The cushions are not included.



Recommended tyre pressure for pneumatic drive wheel tyres: 40–45 PSI.



Max. user weight for Netti V with seat width up to 550 mm 135 kg.  
When used as seat in a car: Max. user weight 135 kg.



When accessories and extra equipment are mounted, the weight of them  
must be subtracted from the max user weight.







The total weight of the user plus seating unit, accessories and extra equipment must not be more than  
135 kg.

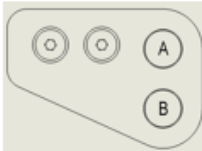

Luggage loaded on to the wheelchair must not exceed 10 kg.  
The luggage must not be placed in a manner that reduce the stability of the chair.

Dealer:	
Frame number.:	
Date:	
Stamp:	

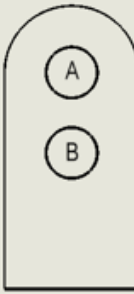
## NETTI V WHEEL POSITIONS - FRONT CASTORS AND ANTI-TIPS

Manoeuvring wheel	Frame hole position- Manoeuvring wheel	Castor wheel size	Castor hole position in front castor	Castor item number	Castor fork item number	Castor wheel item number
						
16"	B	7"	3	94658	94660	94663
						
20"	A	5"	2	90115	90092	86142
20"	B	6"	3	94657	94660	94662
22"	A	6"	4	94657	94660	94662
22"	B	6"	2	94657	94660	94662
22"	B	7"	3	94658	94660	94663
24"	A	6"	2	94657	94660	94662
24"	A	7"	3	94658	94660	94663
24"	A	7" Wide	2	90421	90420	89922
24"	B	7"	1	94658	94660	94663
24"	B	8"	2	94659	94660	94664
26"	A	7"	1	94658	94660	94663
26"	A	8"	2	94659	94660	94664
26"	A	8" Wide	1	90422	90420	89921

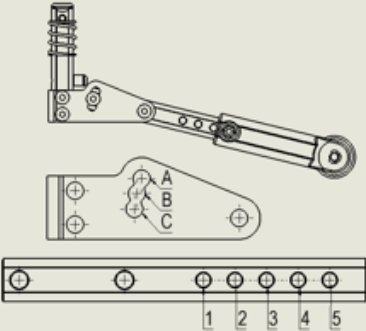
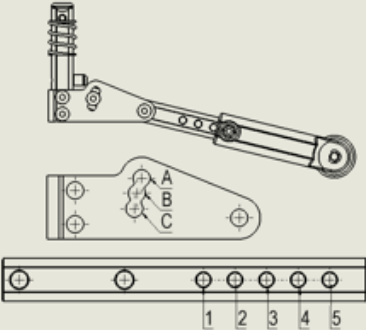
Anti-tip device - position	Seat height - without cushion	Tilt range minus = forwards / plus = backwards
		
B3	386 - 456mm	-5° / +30°
		
C1	345 - 415mm	-5° / +30°
C1	375 - 445mm	-5° / +30°
C1	360 - 430mm	-5° / +30°
B2	390 - 460mm	-5° / +30°
B2	390 - 460mm	-5° / +30°
B2	386 - 456mm	-5° / +30°
B2	386 - 456mm	-5° / +30°
B4	416 - 486mm	-5° / +30°
B4	416 - 486mm	-5° / +30°
B5	414 - 484mm	-5° / +30°
B5	414 - 484mm	-5° / +30°
B5	414 - 484mm	-5° / +30°

# NETTI V SCREW TORQUE

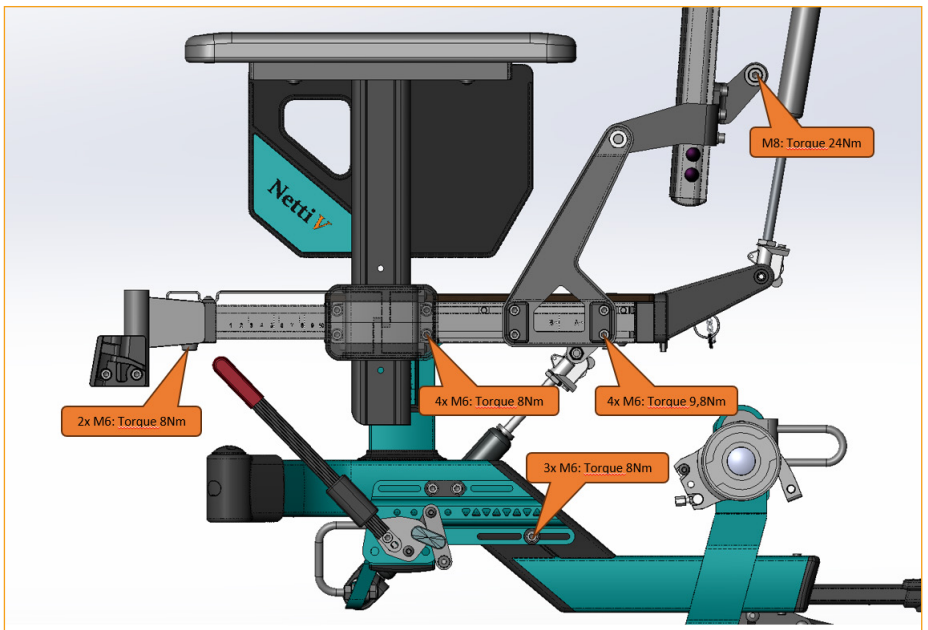
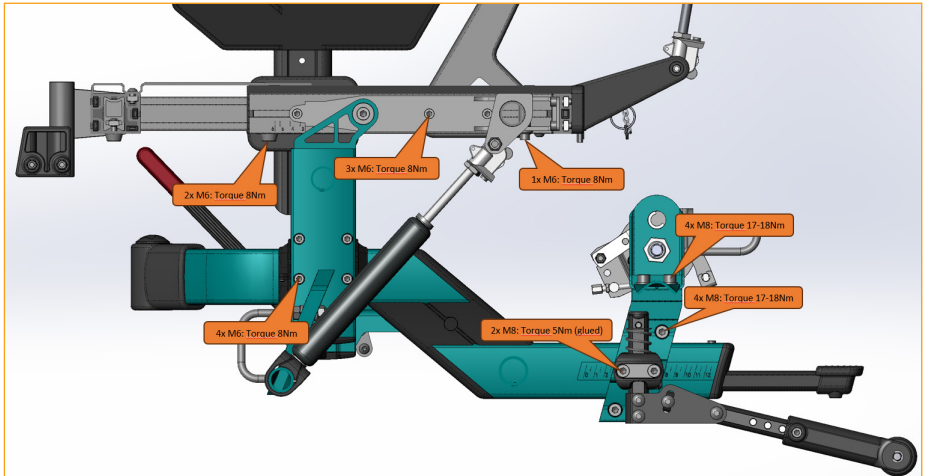

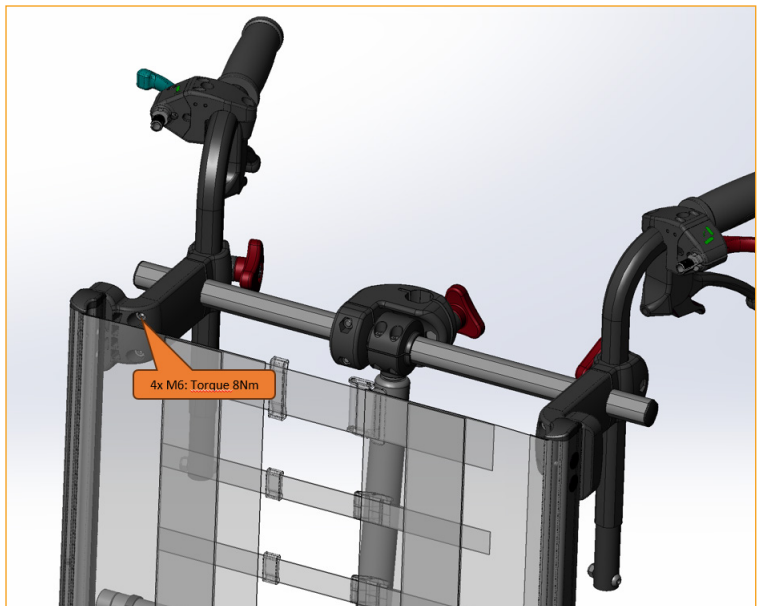
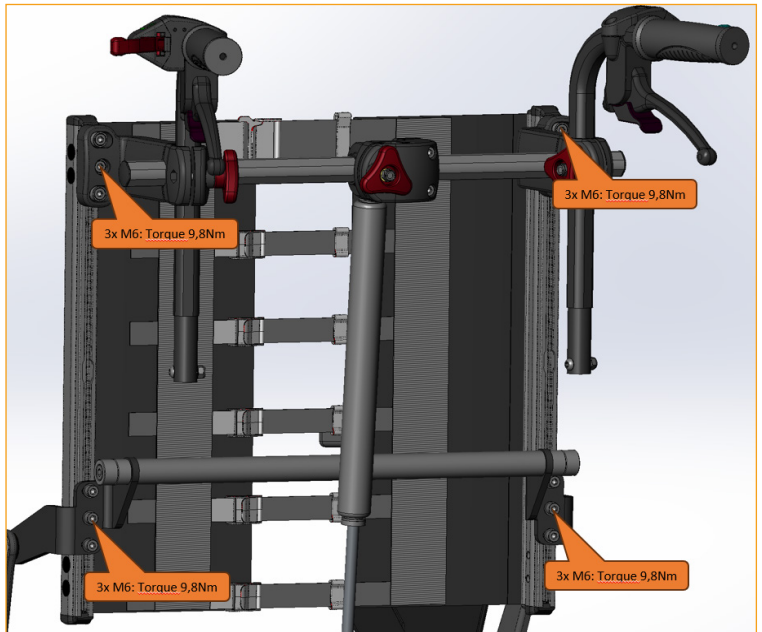



---

**Manufacturer of Netti:**

 Alu Rehab AS  
Bedriftsvegen 23  
N-4353 Klepp Stasjon  
Norway

 [post.klepp@meyragroup.com](mailto:post.klepp@meyragroup.com)  
T: +47 51 78 62 20  
[my-netti.com](http://my-netti.com)