

Washing Manual

with refurbishment information
for Netti manual wheelchairs

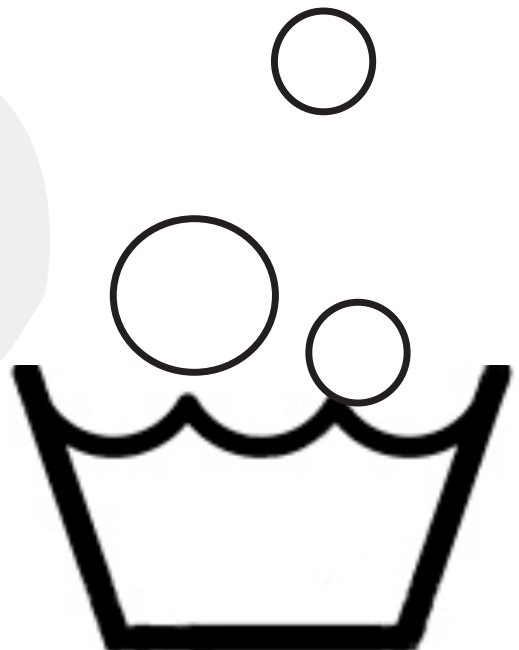

WASHING MANUAL FOR MANUAL WHEELCHAIRS

A comfort wheelchair is an advanced aid for long time seating and mobility. The extensive use makes it being perceived as a part of the user and the state of the wheelchair reflects directly back to how the user is being perceived.

Alu Rehab as manufacturer of wheelchairs takes great pride in making wheelchairs that ensure safe use for user and attendant. We make durable wheelchairs that can be used and reused for very many years, maintaining their functionalities when refurbished properly.

The most effective way to spare the environment is to reuse products made.

Alu Rehab is working to reduce pollution throughout the process of production from the raw material, through development, manufacturing, waste management, refurbishment and recycling of the materials.

That is why we have made a washing manual for regular maintenance and cleaning and a refurbishment manual to make it easy to clean, fix and check wheelchairs for safe and long time use and reuse.

New parts /spare parts, paint, new cushions and upholstery and new wheels can be purchased at Alu Rehab so that even a worn wheelchair can be reused after proper refurbishment.

Thank you for choosing a product from Alu Rehab

All Netti Wheelchairs are tested at an German accredited test laboratory following the European Standard EN-12183.

Netti wheelchairs are crash tested and approved according to ISO 7176-19 at Rise Sweden and TASS Netherlands

WHY REGULAR CLEANING?

There are 3 main reasons for keeping a wheelchair clean:

- * Supporting the user being perceived at his/hers best.
- * Keeping up the technical quality: long technical life - safe use.
- * Preventing germs to spread - disinfection.

There are 4 grades of wheelchair cleaning dependent on the number of users and the surroundings:

1. Personal wheelchair - one user - private surrounding.
2. Personal wheelchair - successively one user at the time - care institutions.
3. Wheelchair in institutions - frequent change of user -
4. Wheelchair in hospitals - frequent change of user - risk for infections.

INCREASED WASHING REQUIREMENTS

Awareness to the need for advanced cleaning and disinfections is rising in the last years following the increasing number of multi resistant bacteria.

Wipe disinfection with hydrogen peroxide after washing with water and mild soap, is for the time being the most gentle way to disinfect a wheelchair.

If however machine washing is required in institutions and hospitals, the Netti wheelchairs will need stripping down before they are placed in the machine. And they will need oiling and greasing of all axles and bearings after each wash before they are assembled and adjusted to a new user.

INDEX

This Manual is divided into four grades of washing methods of the Wheelchair depending on cleaning needs.

GRADE 1 CLEANING PROCEDURE - ONE USER - PRIVATE SURROUNDINGS

- Wheelchair page 4
- Seating system page 4

GRADE 2 CLEANING PROCEDURE - ONE USER - CARE INSTITUTIONS

- Wheelchair page 5

GRADE 3 CLEANING PROCEDURE - FREQUENT CHANGE OF USER

- Wheelchair page 6

GRADE 4 CLEANING PROCEDURE - FREQUENT CHANGE OF USER - HOSPITALS

- Wheelchair - hand wash page 7
- Wheelchair - machine wash page 8

REFURBISHMENT PROCEDURE

- Frame page 9
- Wheel page 9
- Arm Rest page 10
- Back Rest unit page 10
- Push Handles / Push Bow page 10
- Head Support page 10
- Seating Unit page 11
- Back and Tilt mechanism page 11
- Foot Support page 11
- Brakes page 11
- Anti Tip Tubes page 11
- General Information page 11

FUNCTION CHECK page 12

RECEIPT FORM FOR CLEANING AND REFURBISHMENT

This manual can be downloaded from our web-page: www.My-Netti.com

GRADE 1

CLEANING PROCEDURE FOR WHEELCHAIRS ONE USER - PRIVATE SURROUNDING

FREQUENCY: 2 TIMES A MONTH OR MORE DEPENDING ON USE AND NEED

1. Remove back and seat cushion before washing. Please note the position of the cushions. They must be installed at same position and height after cleaning.
2. Clean the wheelchair by sponge and mild detergent. Do not soak seat plate and Velcro back.
3. Rinse wash using clean water to remove soap and degreaser.
4. Use methylated spirit to remove any excess dirt or grease. Universal wipes can also be used.
5. Let air dry. The frame may be polished with car wax to keep it shiny and protected.
6. Remove dirt from axles and wheels with pliers or similar.



Do not use jet water washing, it may damage seat plate, bearings, quick release, gas springs and labels.

CLEANING PROCEDURE FOR SEATING SYSTEM

Always follow the cleaning instruction label on cushions and covers. The table below gives an overview over the most used Netti cushions.

Use washing bag for the covers - the Velcro may cause extra wearing during washing. "Male" part of Velcro can be cleaned with a steel file brush.

	UNO Seat		Netti Sit	
CORE				
Wash	Hand wash 40°C		Hand wash 40°C	
Disinfection	Virkon S	Autoclave 105°C	Virkon S	Autoclave 105°C
Drying	Shake (clench)	Air dry standing	Shake (clench)	Air dry standing
PROTECTION COVER	Not standard			
Wash			Machine wash 60°C	Wipe with soap
Drying			Spin-dry / Air-dry	Do Not Tumble Dry
OUTER COVER				
Wash	Machine wash 60°C		Machine wash 60°C	
Drying	Tumble Dry max 85°C		Tumble Dry max 85°C	

CORE	All Alu Rehab Back Rest Cushions are processed in the same way.	
Wash	No wash	
Disinfection	Virkon S Autoclave 105°C	
Drying	Shake (clench), Air Dry vertical.	
OUTER COVER	Back Cushions are delivered with Easy Care, 3D, and Temp cover	
Wash	Machine wash 60°C.	Temp C°: hand wash
Drying	Temp: Spin-dry, Air Dry, do not tumble dry Easy Care, 3D: Spin-dry, Air Dry, Tumble Dry max 85°C.	

FREQUENCY: 2 TIMES A MONTH OR MORE DEPENDING ON USE AND NEED

1. Remove back and seat cushion before washing. Please note the position of the cushions. They must be installed at same position and height after cleaning when the same user receives the chair back.
2. Clean the wheelchair by sponge and mild detergent. Do not soak seat plate and Velcro back.
3. Rinse wash using clean water to remove soap and degreaser.
4. Use methylated spirit to remove any excess dirt or grease. Universal wipes can also be used.
5. Let air dry. The frame may be polished with car wax to keep it shiny and protected.
6. Remove dirt from axles and wheels with pliers or similar. Oil axles when required.



Disinfection: Wipe the wheelchair with a soft rag wetted with methylated spirit or Hydrogen-peroxide after washing.



Do not use jet water washing, it may damage seat plate bearings, quick release, gas springs and labels.

CLEANING PROCEDURE FOR SEATING SYSTEM

see page 4



Due to hygienic reasons we recommend replacing all upholstery parts when a new user is taking over the wheelchair.

Always follow the cleaning instruction label on cushions and covers. The table on page 4 gives an overview over the most used Netti cushions.

Use washing bag for the covers - the Velcro may cause extra wearing during washing.



“Male” part of the Velcro can be cleaned with a steel file brush.

FREQUENCY: FOR EVERY NEW USER OR MINIMUM 2 TIMES A MONTH

1. Remove back cushion, seat cushion, high adjustable push handles, seat plate and arm support before washing.
The removed parts are to be cleansed by sponge and mild detergent.
2. Clean the wheelchair by sponge and mild detergent. Do not soak seat plate and Velcro back.
3. Rinse wash using clean water to remove soap and degreaser.
4. Use methylated spirit to remove any excess dirt or grease.
5. Remove wheels and turn the wheelchair upside down to remove all water before the wheelchair drip-dries in room temperature prior to greasing and preparation. The frame may be polished with car wax to keep it shiny and protected.
6. Remove dirt from axles and wheels with pliers or similar. Oil axles.
7. Assemble the wheelchair and adjust all parts to make them fit to the new user. Replace damaged parts when required. See refurbishment manual for more information.



Information on how to adjust the wheelchair to a new user is found in the wheel chair manual that can be downloaded from our home page. www.My-Netti.com



Disinfection: Wipe the wheelchair with a soft rag wetted with methylated spirit or Hydrogen-peroxide after washing.



Do not use jet water washing, it may damage bearings, quick release, gas springs and labels.

CLEANING PROCEDURE FOR SEATING SYSTEM

Due to hygienic reasons we recommend replacing all upholstery parts when a new user is taking over the wheelchair.

Always follow the cleaning instruction label on cushions and covers. The table on page 4 gives an overview over the most used Netti cushions.

Use washing bag for the covers - the Velcro may cause extra wearing during washing.



“Male” part of the Velcro can be cleaned with a steel file brush.

GRADE 4 A **CLEANING PROCEDURE FOR WHEELCHAIRS FREQUENT CHANGE OF USERS - HOSPITALS**

FREQUENCY: FOR EVERY NEW USER OR MINIMUM 2 TIMES A MONTH

HAND WASH PROCEDURE:

1. Remove back cushion, seat cushion, high adjustable push handles, seat plate and arm support before washing.
The removed parts are to be cleansed by sponge and mild detergent.
2. Clean the wheelchair by sponge and mild detergent. Do not soak seat plate and Velcro back.
3. Rinse wash using clean water to remove soap and degreaser.
4. Use methylated spirit to remove any excess dirt or grease.
5. Remove wheels and turn the wheelchair upside down to remove all water before the wheelchair drip-dries in room temperature prior to greasing and preparation. The frame may be polished with car wax to keep it shiny and protected.
6. Remove dirt from axles and wheels with pliers or similar. Oil axles.
7. Assemble the wheelchair and adjust all parts to make them fit to the new user. Replace damaged parts when required. See following refurbishment procedure for more information.



Information on how to adjust the wheelchair to a new user is found in the wheelchair manual that can be downloaded from our home page. www.My-Netti.com



Disinfection: Wipe the wheelchair with a soft rag wetted with Hydrogen-peroxide after washing.



Do not use jet water washing, it may damage seat plate, bearings, quick release, gas springs and labels.

CLEANING PROCEDURE FOR SEATING SYSTEM



Due to hygienic reasons we recommend replacing all upholstery parts when a new user is taking over the wheelchair.



It is mandatory to replace all upholstery parts if the last user had infection - possibly with multi-resistant bacteria.

Always follow the cleaning instruction label on cushions and covers. The table on page 4 gives an overview over the most used Netti cushions.



"Male" part of the Velcro can be cleaned with a steel file brush.

NEXT PAGE: MACHINE WASH PROCEDURE.

GRADE 4 B **CLEANING PROCEDURE FOR WHEELCHAIRS FREQUENT CHANGE OF USERS - HOSPITALS**

FREQUENCY: FOR EVERY NEW USER OR MINIMUM 2 TIMES A MONTH

MACHINE WASH PROCEDURE:

1. Remove back cushion, seat cushion, high adjustable push handles, seat plate (if wooden) and arm support before washing. Polycarbonate seat plate can take machine washing and must not be removed.

The removed parts are to be cleansed outside the washing machine by sponge and mild detergent.

2. Clean the wheelchair by placing it in the washing machine.
Max temperature 60°C and 6 minutes.
3. After complete washing program remove the wheels and turn the wheelchair up side down to remove all water before the wheelchair drip-dries in room temperature prior to greasing and preparation. The frame may be polished with car wax to keep it shiny and protected.
4. Remove dirt from axles and wheels with pliers or similar. Oil all axles and bearings.
5. Assemble the wheelchair and adjust all parts to make them fit to the new user. Replace damaged parts when required.

See following refurbishment procedure for more information.



Information on how to adjust the wheelchair to a new user is found in the wheel chair manual that can be downloaded from our home page. www.My-Netti.com

CLEANING PROCEDURE FOR SEATING SYSTEM



Due to hygienic reasons we recommend replacing all upholstery parts when a new user is taking over the wheelchair.



It is mandatory to replace all upholstery parts if the last user had infection - possibly with multi-resistant bacteria.



Always follow the cleaning instruction label on cushions and covers. The table on page 4 gives an overview over the most used Netti cushions.



“Male” part of the Velcro can be cleaned with a steel file brush.

REFURBISHMENT PROCEDURE

Before working on the wheelchair it is advisable to place the wheelchair on a raised table or bench giving an ergonomically correct position, avoiding any unnecessary lift. Use recommended, high quality tools and refer to the User Manual that can be downloaded from our home page www.My-Netti.com.

Clean the Wheelchair - see Cleaning Procedure Page 4, difficult stains remaining after the cleaning process can be removed with methylated spirit. For oiling or greasing - remove cushions, head support, leg supports, main wheels, front castors, arm supports and any other accessories. Tilt the wheelchair rearwards on to the anti tip tubes.

FRAME :

Check the frame for deformations, breakages, damage, abrasions, and missing screws, bolts and nuts. Worn parts must be replaced, and oiled if necessary. Deformed frame and parts must be scrapped.

MAIN WHEEL:

Main wheels and push rims can be cleaned with soapy water or methylated spirit. Clean the rims and check tyres for damage and cracks, replace if necessary. Oil the quick release/main wheel axle. Check that the quick release locks the main wheel when mounted on the wheelchair. This is done by pulling the main wheel after mounting making sure the wheel is firmly attached.

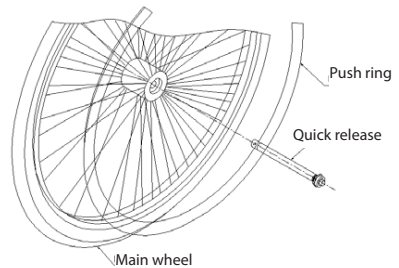

FRONT CASTORS AND FRONT FORKS:

Clean the front forks with methylated spirit. Oil the quick release axle and check for play. If there is play in the quick release axle, remove it, clean it with methylated spirit and apply Thread Lock glue to secure the front fork within the bearing house.

Dismantle the front castors from the front forks for cleaning with methylated spirit and check for play in the bearing. Replace the front castors if worn. Check that the quick release locks the front castor when mounted on the wheelchair (see User Manual for further details).

For correct manoeuvring check that the bearing house is mounted vertical in relation to the ground (see User Manual for further details).

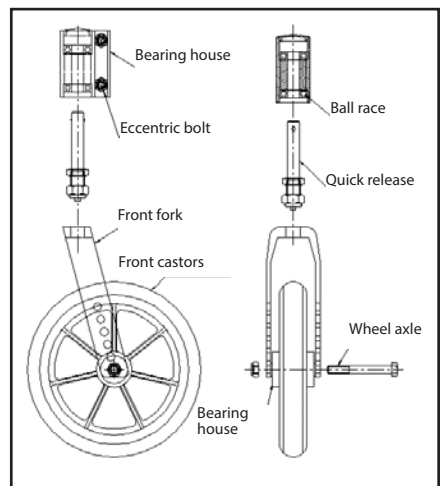

- **ARM SUPPORTS - NETTI III/ NETTI V:**

Check that the lock track is cleaned. Ensure that the position screw is mounted and in the correct position. Check that the arm support pads are mounted with two screws on each side, check that the screws are tight. Place the arm support in the cleaned arm support bracket on the frame, Move the arm support forwards and rearwards slowly while screwing the lock screw inwards. When play in the arm supports has been removed, tighten the lock nut.

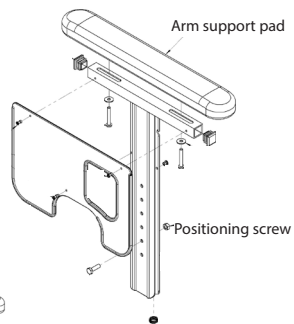

- **ARM SUPPORT LOCK NETTI 4U:**

Ensure that the lock and release mechanism works. Check depth/length displacement of the arm support pads, tighten the screws in the arm support pads.

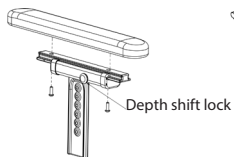

- **PUSH HANDLES :**

Check the push handles for wear and damage. If hand-grips are worn, the complete push handle must be replaced. Ensure that the security screw is fitted. Check that the shelter studding in the plastic bracket is not deformed.

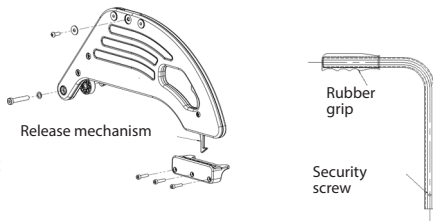

- **PUSH BOW:**

Check all screws and fastening points. Remove loose screws, clean with methylated spirit and re-fit using Thread Lock glue, (full locking). Check that the tilt and back release handles are marked with correct symbols. Replace adjusting handles and wheels if necessary.

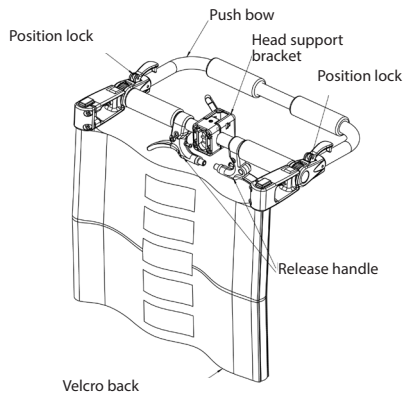

If the cleaning routine has not been followed and driving handles/hand grips have been incorrectly cleaned, replace with new.

- **BACK REST UNIT:**

Check Velcro back for damage in sewing and lock. If necessary clean the Velcro with a damp cloth. Tighten the straps. The Velcro "male" can be cleaned with a steel file brush.

- **HEAD SUPPORT:**

Check that the head support is clean and that there are no abrasions or tears. Replace the head support if the wheelchair is for a new user. Oil screws and wheels. Check and replace handles and wheels if necessary.

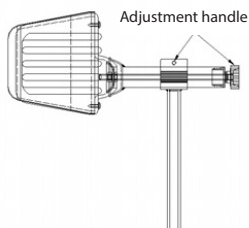

- **SEATING UNIT:**

Check the seating plate for breakage or cracks and missing screws. Clean the seat cushion in accordance with cleaning instructions on the cushion label or replace. See cleaning procedure for seating system, Page 4).

- **BACK AND TILT MECHANISM:**

Check the gas springs for damage and replace if necessary. Adjust and oil wires and cables and cable transfers. Clean and oil the piston rod on the gas spring.

- **LEG SUPPORT:**

Check and adjust wheel/handles, check that no adjustment screws are damaged or missing. Tighten loose screws/nuts and oil all moveable parts. Do not oil the adjustment bar in the mechanical lock. Check the mechanical lock on the angle adjustable leg supports and if necessary replace the lock cone. Remove and check the fit of the leg supports to the frame. If necessary replace the leg support brackets.

- **PARKING BRAKES:**

Check that all screws are in place and tight. If parts are loose or missing, replace the complete brake for security reasons. Adjust the brakes blocking the wheels when activated using reasonable force. Drum brakes are cleaned and adjusted locking the wheels by full handle pull.

- **ANTI TIPS:**

Check the engagement and disengagement of the anti tip tubes in the up and down positions. Adjust the anti tip tubes in relation to the main wheels, (see User Manual for correct adjustment).

- **GENERAL INFORMATION:**

Use Alu Rehab AS original parts only. Use light bicycle oil on moveable parts and bearings. Use HHS Lube (Würth) on Gas Springs.

Recommended glue:

Loctite 2701 Thread Lock - full lock.

Loctite 243 Thread Lock - part lock.

Silver colour code: RAL 9007

Graphite grey colour code: RAL 7024

Black code colour: RAL 9005

Always have the User Manual available.

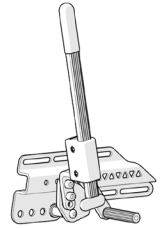
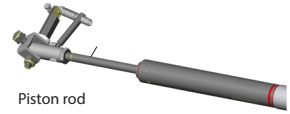

Brake handle

Brake handle

Brake shoe

Brake shoe

Clamp

Clamp

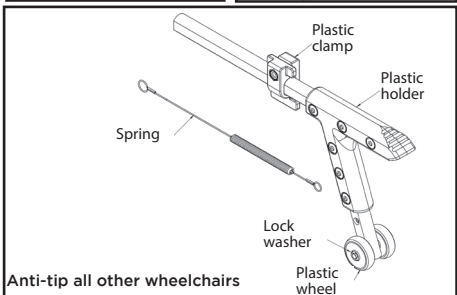
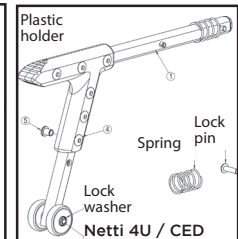
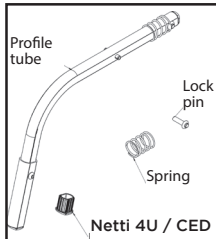
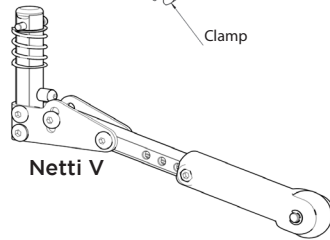

FUNCTION CHECK BEFORE DELIVERY TO USER/CUSTOMER

Check that the wheelchair is adjusted according to order.

Visual check:

- All pins, plugs and screws are correctly fitted.
- Check the sewing in the Velcro back, no loose threads shall be seen.
- Check that the seating plate is in good condition and correctly adjusted for seat depth.
- Check that the Netti Comfort seat plate fabric is intact.

Make sure the user manual for the wheelchair is at hand by refurbishing.

Function	Model	Test/check	Done/OK
Tilt	Netti III family Netti S Netti 4U family Netti Dynamic family Netti AdaptPro family Netti V family	Move the tilt functions in both outer positions and check there is free movement. Check that wires run free of obstructions. Check that the tilt function is marked with correct labels.	
Back-recline regulation	Netti III family Netti S Netti 4U family Netti Dynamic family Netti AdaptPro family Netti V family	Move the back recline regulation in both outer positions and check there is free movement. Check that wires run free of obstructions. Check that the recline function is marked with correct labels.	
Push handles	All wheelchairs, except Netti 4U CED and BASE Netti AdaptPro family Netti S	Check that hand grips are free from abrasion and damage. Check that driving handles adjust freely and lock in position. Check that the stop screw and the small steel plate are correctly fitted.	
Push bow	Netti 4U CED Netti S Netti AdaptPro family	Check that the push bow is secure and lock in position.	
Head support	All wheelchairs	Check that the small set screw in the centre on top of the head support adapter is tightened and that the small steel plate is correctly mounted. Check the head support is clean and intact and that adjustment handles function correctly.	
Arm support	Netti III family Netti S Netti 4U family Netti Dynamic family Netti AdaptPro family Netti V family	Check that the arm support pads match and are adjusted similarly on both sides. Check that the height adjustment locks correctly. Adjust the plastic screws in the arm support bracket and tighten the lock nut, the arm support should slide easily within the arm support bracket. The stop screw should be adjusted to the same height on both sides. The slide mechanism should operate easily. Check that the arm support locks when swung forward.	

Function	Model	Test/check	Done/OK
Bearing housing	All models except Netti 4U family Netti AdaptPro family Netti V family	Ensure the bearing housing is adjusted in position vertical to the horizontal ground.	
Front castors	All wheelchair models	The front castors quick release should operate freely on and off and lock them in the secure position. Check there is minimum free play in the quick release lock. Check both front castors are mounted in the same hole position on the front forks.	
Main wheel	All wheelchair models	Check that the main wheels lock securely and that the quick release operates freely on and off. Check there is minimum free play in the quick release lock. Check both main wheels are mounted in the same hole position in the wheel-frame bracket. There should be no free play in the push rims.	
Brakes	All wheelchair models	Check that the brakes are equally adjusted on both sides and that they lock the main wheels securely with as little required force as possible.	
Extension piece leg support	All wheelchair models	The extension piece should be securely fastened and equally adjusted on both sides.	
Leg support angle adjustable	Netti III family Netti S Netti 4U family Netti Dynamic family Netti AdaptPro family Netti V family	Check if the angle lock locks into desired angles and the leg support is easy to mount and remove. There should be no free play in the locking bracket. Check that it is easy to move and fix the length adjustment. The calf supports should be equal adjusted on both sides. The knee upholstery should be clean.	
Leg support universal	Netti III family Netti S Netti 4U family Netti Dynamic family Netti AdaptPro family Netti V family	Check the connection between the leg support and the frame; that it is easy to mount and remove them. There should be no free play in the locking bracket. Check that it is easy to move and fix the length adjustment	
Anti tip tubes	All wheelchair models	Check that the adjustment is equal on both sides and that the position is correct relative to the main wheels. Check engagement and disengagement of the anti tip tubes up, down, inn and out. Check that the anti tip tubes are correctly labelled.	
Directional stability	All wheelchair models	Push the wheelchair with equal power on both sides of the push bar, allow the wheelchair to roll forward freely. The wheelchair should roll forwards in a straight line, if not, adjust the front castors and main wheels, (see User Manual).	

RECYCLING

The wheelchair is designed to make it easy to separate the chair's components into individual materials to make recycling as easy as possible. See Alu Rehab's Recycling Manual SM0032 to get an overview of which materials are used for the various components and how they can be separated and recycled. Always consider repair and reuse before disposal. The most environmentally friendly thing is to reuse if possible.

Contact your local recycling centre for information on which components and materials they can recycle. The lowest level of recycling is to separate metal, plastic + foam components and wood. The highest level is to distinguish between the individual types of metal, plastic types and wood.



Gas springs, batteries and electrical components must always be kept separate containers and delivered to authorized recycling stations. Broken parts can become raw material for new products!

RECEIPT FORM FOR EXECUTED WASHING AND REFURBISHMENT PROCEDURE

- **Frame number/serial number**

- **PROCEDURE EXECUTED OK:**

• Cleaning procedure

• Refurbishment procedure

• Function control

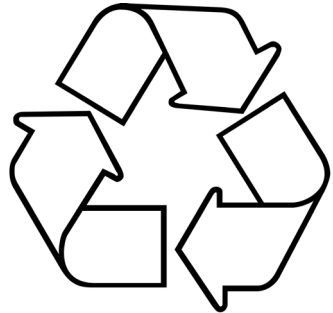

All the points above have been executed and the wheelchair is ready for delivery

Company name:

Technician:

.....
Place - Datum:

.....
Signature:

.....
This filled out refurbishment manual shall follow the refurbished wheelchair to the end user, documenting that the wheelchair has been refurbished according to the wheelchair manufacturer recommendations. This assures maintaining the end user safety and the long life wheelchair function.

• **PROCEDURE EXECUTED OK:**

- Cleaning procedure
- Refurbishment procedure
- Function control

All the points above have been executed and the wheelchair is ready for delivery

Place and date:

Technician:

.....

• **PROCEDURE EXECUTED OK:**

- Cleaning procedure
- Refurbishment procedure
- Function control

All the points above have been executed and the wheelchair is ready for delivery

Place and date:

Technician:

.....

• **PROCEDURE EXECUTED OK:**

- Cleaning procedure
- Refurbishment procedure
- Function control

All the points above have been executed and the wheelchair is ready for delivery

Place and date:

Technician:

.....

*inspire
joy of life*

Manufacturer:

Alu Rehab AS
Bedriftsvegen 23
N-4353 Klepp Stasjon
Norway



✉ post.klepp@meyragroup.com
T: +47 51 78 62 20
my-netti.no

Distributor

Alu Rehab ApS
Kløftehøj 8
DK-8680 Ry
Denmark



✉ info.ry@meyragroup.com

T: +45 87 88 73 00
F: +45 87 88 73 19
my-netti.dk

